

USER'S MANUAL REL. 1.00

**SYNTHESIS
SPOT 700**
PROFESSIONAL
MOVING HEAD

- GB
- I
- D
- F
- E
- P

 **SGM**[®]
Technology for Lighting



Vi ringraziamo per aver acquistato un prodotto SGM.

Per ottenere i migliori risultati dal suo utilizzo, vi preghiamo di leggere attentamente questo manuale di istruzioni. Al suo interno troverete le informazioni tecniche e le specifiche d'uso del prodotto. Nelle pagine in appendice troverete inoltre schemi e diagrammi destinati all'assistenza tecnica.

Nell'ottica di qualità SGM, è possibile che l'Azienda apporti migliorie ai suoi prodotti, per cui consigliamo di allegare il manuale al prodotto stesso e di trascrivere il numero di serie nell'ultima pagina della copertina: utilizzando il presente manuale con un apparecchio fabbricato prima o dopo la sua stampa, potrebbero esserci discrepanze fra l'apparecchio e quanto riportato nel Manuel stesso.



Thank you for buying an SGM product.

To obtain the best results, please carefully read this instruction manual in which you will find technical information and specifications for use of the product, as well as diagrams for technical service in the appendix.

In light of SGM quality, the company may make improvements to its products. Therefore, we recommend that the manual be attached to the product and the serial number copied onto the back cover: using this manual with equipment manufactured before or after its printing, might show discrepancies between the equipment and the information listed in the manual.

Wir danken Ihnen für den Kauf eines Produkts von SGM.

Zur Erzielung der besten Resultate bei der Benutzung bitten wir Sie, die vorliegende Bedienungsanleitung aufmerksam zu lesen. Darin finden Sie die technischen Informationen sowie die Anweisungen für die Benutzung des Produkts. Im Anhang befinden sich außerdem die Schaltpläne und Diagramme für den Kundendienst.

SGM behält sich das Recht vor, Verbesserungen an den Produkten vorzunehmen und deshalb empfehlen wir, die Bedienungsanleitung dem Produkt stets beizulegen und die Seriennummer auf der letzten Seite des Umschlages einzutragen. Bei der Verwendung dieses Handbuchs mit einem Gerät, das vor oder nach der Drucklegung produziert wurde, können sich Abweichungen zwischen Gerät und dem Inhalt des Handbuchs ergeben.

Nous vous remercions d'avoir acheté un produit SGM.

Pour optimiser son utilisation, nous vous prions de bien vouloir lire attentivement cette notice où vous trouverez les informations techniques et les caractéristiques d'utilisation du produit. En outre, vous trouverez également, dans les pages en appendice, les schémas et les diagrammes concernant l'assistance technique.

Le concept de qualité SGM, lui permet d'améliorer continuellement ses produits et c'est pourquoi nous vous conseillons de joindre la notice au produit et d'inscrire le numéro de série sur la page de couverture. En effet, si on l'utilise avec un appareil fabriqué avant ou après son impression, il peut y avoir des différences entre l'appareil et ce qui figure dans la notice.

Les estamos sumamente agradecidos por haber elegido un producto SGM.

Para obtener los mejores resultados, les rogamos leer detenidamente el presente manual de instrucciones. El mismo contiene las informaciones técnicas y las indicaciones de uso del producto. Las páginas anexas contienen además los esquemas y diagramas necesarios para la asistencia técnica.

Para mantener la calidad SGM, es posible que la Empresa aporte mejoras sus productos, por ello les aconsejamos conservar el manual junto con el aparato correspondiente y escribir su número de serie en la última página del manual; si en cambio se utiliza el presente manual con un aparato frabricado antes o después de su impresión, es probable que existan discrepancias entre el aparato y las indicaciones del mismo.

Table of Contents

SYMBOLS USED	2
CHANGES TO THIS MANUAL	2
GENERAL WARNINGS	3
GENERAL WARRANTY CONDITIONS	4
1 INTRODUCTION	5
1.1 MAIN FEATURES	5
LAMP	5
EFFECTS	5
MOVEMENT	5
ELECTRONIC BALLAST	5
OPTIC	6
DISPLAY/MICROCOMPUTER	6
CONTROL CHANNELS	6
MOUNTING SYSTEM	6
1.2 ACCESSORIES	6
AS STANDARD:	6
OPTIONAL (ON REQUEST):	6
1.3 ELECTRICAL SPECIFICATIONS	7
1.4 MECHANICAL FEATURES	9
2 INSTALLATION	10
2.1 EQUIPMENT	10
2.2 POWER CABLE CONSTRUCTION	10
2.3 INSTALLING THE FIXTURE ON A SUPPORT STRUCTURE	11
2.4 POSITIONING THE FIXTURE	11
2.5 FITTING CLAMPS	12
CONSTRUCTION OF THE SIGNAL CABLE	13
CABLES CONNECTIONS	13
CONSTRUCTION OF THE DMX TERMINATION	14
WIRELESS DMX	14
RDM (REMOTE DEVICE MANAGEMENT)	14
RS-232 CONNECTION	15
2.6 FIRMWARE UPDATING	15
2.7 ACCESS TO INTERNAL COMPONENTS	16
INSTALLING / REPLACING THE LAMP	17
LAMP ALIGNMENT	18
INSTALLING / REPLACING GOBOS	19
INSTALLING / REPLACING THE ANIMATION WHEEL	19
INSTALLING / REPLACING THE COLOR FILTERS	20
3 MICRO COMPUTER CONTROL	21
3.1 MICROCOMPUTER "CONTROL"	21
3.2 LONGLIFE RECHARGEABLE BUFFER BATTERY	21
3.3 NAVIGATING THE MENU	21
3.4 STRUCTURE OF THE MENU	22
3.5 ERROR MESSAGES	35
4 MAINTENANCE	36
4.1 ORDINARY MAINTENANCE	36
BUFFER BATTERY REPLACEMENT	37
LAMP REPLACEMENT	37
5 CONTROL CHANNELS	38

Symbols used

This manual uses graphic symbols to emphasize any hazards during the operation work described.



THIS SYMBOL INDICATES A GENERAL RISK

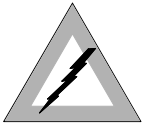

THIS SYMBOL INDICATES ELECTRIC SHOCK RISK



THIS SYMBOL INDICATES A HOT SURFACE



THIS SYMBOL MEANS "DO NOT PLACE THE UNIT ON INFLAMMABLE PARTS OR MATERIAL"

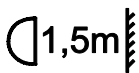

THIS SYMBOL INDICATES THAT THE MINIMUM DISTANCE BETWEEN THE FIXTURE AND THE SURFACE TO BE LIT MUST BE NO LESS THAN 1.5 METRES.

Changes to this manual

SGM has an on-going product development policy, so the information printed in this manual may not be completely up to date.

If any doubts arise regarding the topics covered in this manual or should any further help be required, our online services (internet-server www.sgm.it) are available 24 hours a day. In the FAQ section of the technical assistance zone, answers can be found to numerous common queries: fixtures, firmware and manuals can also be downloaded whenever required.



General Warnings

Read the instructions in this handbook carefully, as they give important information regarding safety during installation, use and maintenance.

Be sure to keep this instruction manual with the fixture, in order to consult it in the future. If the fixture is sold or given to another operator, make certain he or she also receives the manual, to be able to read about its operation and follow the relative instructions.

THIS UNIT IS NOT FOR HOME USE, ONLY PROFESSIONAL APPLICATIONS

AFTER HAVING REMOVED THE PACKAGING, CHECK THAT THE FIXTURE IS NOT DAMAGED IN ANY WAY. IF IN DOUBT, DON'T USE IT AND CONTACT AN AUTHORIZED SGM TECHNICAL SERVICE CENTRE.



PACKAGING MATERIAL (PLASTIC BAGS, POLYSTYRENE FOAM, NAILS, ETC.) MUST NOT BE LEFT WITHIN CHILDREN'S REACH, AS IT CAN BE DANGEROUS.

THIS FIXTURE MUST ONLY BE OPERATED BY ADULTS. DO NOT ALLOW CHILDREN TO TAMPER OR PLAY WITH IT.



ELECTRICAL WORK NECESSARY FOR INSTALLING THE FIXTURE MUST BE CARRIED OUT BY A QUALIFIED ELECTRICIAN OR EXPERIENCED PERSON.

NEVER USE THE FIXTURE UNDER THE FOLLOWING CONDITIONS:

- | | | |
|----|---|------------------|
| 1. | SUBJECT TO EXCESSIVE HUMIDITY | IN PLACES |
| 2. | SUBJECT TO VIBRATIONS OR BUMPS. | IN PLACES |
| 3. | TEMPERATURE OF OVER 45°C OR LESS THAN 2°C | IN PLACES WITH A |

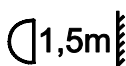

PROTECT THE FIXTURE FROM EXCESSIVE DRYNESS OR HUMIDITY (IDEAL CONDITIONS ARE BETWEEN 35% AND 80%).



DO NOT DISMANTLE OR MODIFY THE FIXTURE.

MAKE CERTAIN THAT NO INFLAMMABLE LIQUIDS, WATER OR METAL OBJECTS ENTER THE FIXTURE.

THE MINIMUM DISTANCE BETWEEN THE FIXTURE AND THE SURFACE TO BE LIT MUST BE NO LESS THAN 1.5 METRES

SHOULD ANY LIQUID BE SPILLED ON THE FIXTURE, DISCONNECTED THE POWER SUPPLY TO THE FIXTURE IMMEDIATELY.

IN THE EVENT OF SERIOUS OPERATING PROBLEMS, STOP USING THE FIXTURE IMMEDIATELY AND EITHER CONTACT THE NEAREST SGM SALES POINT FOR A CHECK OR CONTACT THE MANUFACTURER DIRECTLY.

DO NOT OPEN THE FIXTURE -THERE ARE NO USER SERVICEABLE PARTS INSIDE.

NEVER TRY TO REPAIR THE FIXTURE YOURSELF. REPAIRS BY UNQUALIFIED PEOPLE COULD CAUSE DAMAGE OR FAULTY OPERATION. CONTACT YOUR NEAREST AUTHORIZED SERVICE CENTRE.

WHEN CARRYING OUT ANY WORK, ALWAYS COMPLY SCRUPULOUSLY WITH ALL THE NORMS (PARTICULARLY REGARDING SAFETY) CURRENTLY IN FORCE IN THE COUNTRY IN WHICH THE FIXTURE'S BEING USED.

ALWAYS INSIST ON ORIGINAL SPARE PARTS BEING FITTED

General warranty conditions

- The unit is guaranteed for 24 months from the date of purchase against manufacturing material defects.
- Breakdown caused by carelessness and improper use of the fixture is excluded.
- The guarantee is no longer valid if the unit has been tampered with or repaired by unauthorized personnel.
- Replacement of the fixture is not foreseen by the guarantee.
- External parts, knobs, switches, removable parts and lamps are excluded from the guarantee
- Transport costs and related risks are borne by the fixture's owner.
- The guarantee is valid to all effects only on presentation of the guarantee certificate to the manufacturer or the nearest SGM technical assistance centre.
- Always quote the unit's serial number and model when contacting your reseller for information or assistance.

Protect the environment: don't throw packing material into your garbage can return it to your SGM retailer or take it to the nearest special waste collection point.

1 INTRODUCTION



1.1 Main features

Synthesis is the SGM new professional moving head thought to be used in big show events, theater, television and entertainment venues in general. Developed by SGM tenth years experience in the mechanical and electrical engineering, for its advanced performances Synthesis is at the top of the best worldwide production.

The Osram HTI 700W SE/75 lamp used along with a perfect optical group makes Synthesis one of the best among the fixtures on the market.

LAMP

▪ Lamp:	HTI 700W SE (7200°K)	HTI 700W SE (5600°k)
▪ Luminous flux:	59000 Lumen	59000 Lumen
▪ Color temperature:	7200°K	5600°K
▪ Lifespan	750 H	750H
▪ Lamp Base	Fax 1.5	Fax 1.5

EFFECTS

- Linear zoom from 9° to 32°
- Electronic and automatic focus 16 bit
- Linear dimmer (0-100%)
- Shutter/Strobe 12 flash/ sec. with music synchronism
- 2 gobo wheels with 8 rotating indexable 16 bit positions + white
- Color wheel with 6 positions + white
- CMY system for colors generation + variable CTO .
- Gobos scrolling adjustable speed
- Gobo shake- rainbow effect on gobo wheel.
- Colorchange and gobo change with black/out
- Colorchange and gobo change with music synchronism
- 2-tons beam, analogic color selection, rainbow at 16 speeds
- 1 prism with 4 faces, rotating at adjustable speed in both directions
- Animation wheel positioning on 360°, rotating and indexable
- Frost linear filter, from soft-edge to full-wash
- UV Filter
- Iris
- Macro

MOVEMENT

- 530° for Pan (4s) and 250° for Tilt (3.4s)
- Resolution of the 8/16 bit movement
- Auto repositioning in case of random head moving
- Possibility of inverting Pan/Tilt movement
- Possibility of reducing the scanning range of Pan/Tilt movement
- Possibility of changing acceleration parameters and speed
- Pan and tilt automatic unlock when powering the fixture
- Tracking or Vector operating modes

ELECTRONIC BALLAST

- Supplied as standard with every fixture
- Power supply with PFC (universal 90/245V 50/60Hz)
- Flickerfree- lamp power reduction in case of fixture overheating
- Power Factor Correction
- Automatic energy saving in the event of beam black-out
- Hot re-strike
- Protection against 380V and 90V

OPTIC

- Optic with high luminous efficiency
- Projection angle linear regulation (from 9° to 32°)
- 16 bit motorised focus

DISPLAY/MICROCOMPUTER

- Long lasting rechargeable buffer battery supplied as standard to modify the display settings by not powered fixture
- Graphic display 140x16
- Customizable fixture through internal microcomputer
- Test functions available for every effect
- ON/OFF enabling lamp strike by remote control
- Fixture RESET enabling by remote control
- Starting DMX channel indexing
- Control of the display brightness
- Hours counter and lamp strikes counter
- Fixture life counter
- Software update via DMX

CONTROL CHANNELS

- DMX 512 – RS 232 input signal
- 35 DMX channels
- Wireless DMX interface as standard
- RDM protocol implemented on DMX (internal parameters monitoring)

MOUNTING SYSTEM

- "Fast-Lock" clamps supplied as standard with fixture
- Several clamp mounting points to enable the fixture to be mounted on any type of truss
- Safety chain/cable mounting points

1.2 Accessories**AS STANDARD:**

- | | |
|--------------------------------------|--------------|
| ▪ User Manual | cod: M001249 |
| ▪ Clamp | cod: G000035 |
| ▪ Power Con connector | cod: P150120 |
| ▪ XLR 5 pins female connector | cod: P150102 |
| ▪ XLR 5 pins male connector | cod: S050067 |
| ▪ Antenna Wireless | cod: A020001 |
| ▪ Osram Lamp HTI 700W/SE/75 (7200°K) | cod: L010149 |
| ▪ 9 faces DIA.45 Prism assembly | cod: 2101429 |
| ▪ DIA.45 additional lens assembly | cod: 2101427 |
| ▪ DIA. 4 safety cable | cod: A080035 |

OPTIONAL (ON REQUEST):

- | | |
|--------------------------------------|----------------|
| ▪ Osram lamp HTI 700W/SE/75 (5600°K) | cod: |
| ▪ Single Flight case | cod: 0061745 |
| ▪ Double Flight case | cod: 0061746 |
| ▪ Animation wheel: Bubbles | cod: D2N0003 |
| Clouds | cod: D2N0003 |
| Crazy blaze | cod: D2N0007 |
| Clouds-2 | cod: D2N0004 |
| Sectors | cod: D2N0005 |
| Sectors-2 | cod: D2N0006 |
| ▪ Gobos (ref. SGM gobo catalogue) | |

1.3 Electrical Specifications



POWER REQUIREMENTS: Univesal 90V-245 V 50Hz,60Hz.

POWER ABSORBED: 1000W@230V 50Hz

PROTECTION FUSES: 2x16 Amp

ADDITIONAL ELECTRONICAL PROTECTIONS:

In addition to the traditional electrical fuse protection, Synthesis is fitted with sophisticated electronical systems able to protect the fixture from overvoltage or dangerous low voltage, avoiding, in this way, damages to the electronic boards as usually happens in these kind of situations. The electronic ballast fitted as standard, allows a wide possibility to use the fixture with any power supply included between 90-240 Volts 50 or 60 Hz, exposing anyway Synthesis to the more common risks in the electrical installations on mondial level (neutral detachment or fluctuating low voltage). For this reason SGM has developed a system able to protect Synthesis from the common problems of the electrical installation, making everything transparent to the end user. The protections are:

1. Protections against the overvoltage.

In case of power supply over 280 Vrms, due to the neutral detachment, the internal protection detects the overvoltage preventing the fixture's switching on. The display, powered by the internal battrey, will show the error message "POWER OVERVOLTAGE"

2. Protections against the low voltage.

This second case involves all those countries where the power supply is 100-120Volts. In this second case we can meet two different situations:

- In the first situation, we have a fixture already powered at 100 Volts and, for some reasons, the power supply lowers under 80 Volts. In this case, Synthesis detects the low voltage but keeps on working normally. If this situation lasts for a long time, then the internal temperatures will increase until the temperature protections won't stop the internal powering.
- In the second situation, Synthesis is not yet powered and, by swithcing on the fixture, it immediately detects that the voltage is already under 80 Volts. In this case, the internal protection will provide to lock the fixture immediately.

LAMP SPECIFICATIONS

Synthesis is fitted with Osram HTI 700W SE/75 lamp.

This lamp is able to generate a color temperature of 7200°K, alternatively the same lamp is available but with color temperature of 5600°K with a life of 750h.

The lamp is hot restrike, thanks to its electronic ballast, Synthesis can have this function as standard.

Lamp:	HTI 700W SE (7200°K)	HTI 700W SE (5600°k)
▪ Luminous flux:	59000 Lumen	59000 Lumen
▪ Color coordinates:	Y. 332 X. 345	-..... -
▪ Color temperature:	7200°K	5600°K
▪ Luminous efficacy:	85 lm/W	85lm/W
▪ Average Life (50%)	750 H	750H
▪ Lamp base	Fax 1.5	Fax 1.5

OPTICAL SYSTEM:

Internal optical group composed by high luminous efficiency dichroic reflector; linear beam angle adjustment (9° to 32°) electronic focus.

METAL GOBO

EXTERNAL DIAMETER: 30 mm
IMAGE AREA: 24 mm

DICHROIC GOBO

EXTERNAL DIAMETER: 28 mm
IMAGE AREA: 24 mm
THICKNESS: 1,1 mm

COLOR FILTERS

EXTERNAL DIAMETER: 34 mm
THICKNESS: 1,1 mm

SETTING: via internal microcomputer

CONTROL SIGNAL: USITT DMX 512

DMX CONTROL CHANNELS: 35 Ch

1.4 Mechanical features

BODY: Alluminum moldings and Termhopolicarbonate plastic covers

WEIGHT: 42 KG

SIZES in mm:

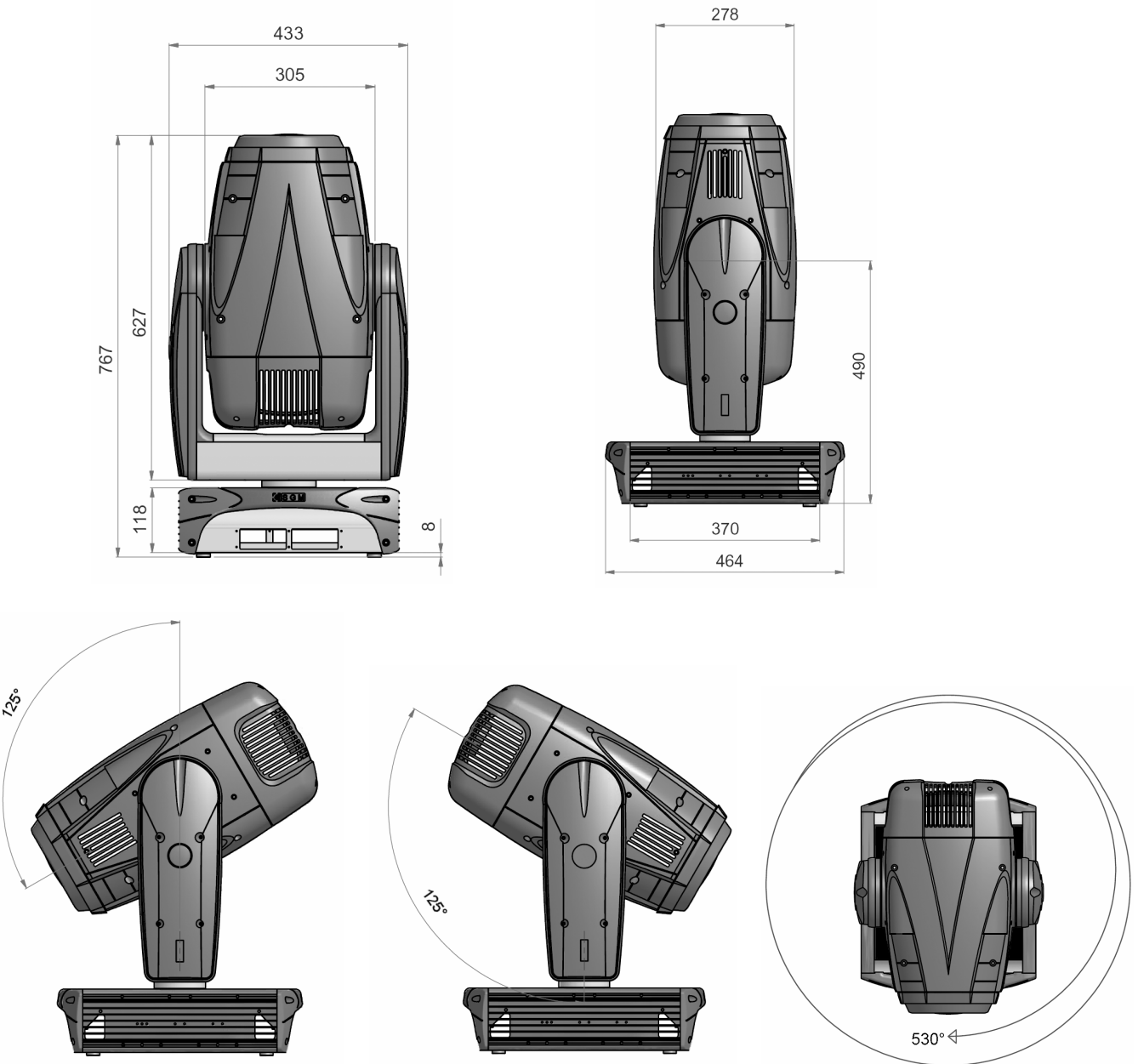

SGM TECHNOLOGY FOR LIGHTING RESERVES THE RIGHTS TO IMPROVE OR MODIFY ITS PRODUCT AT ANY TIME WITHOUT PRIOR NOTICE. ALWAYS REFER TO THE MANUAL SUPPLIED WITH THE UNIT TO AVOID ANY RISK OF MISTAKE OR OPERATION WHICH DOES NOT CORRESPOND TO THE MANUAL INDICATIONS.

2 INSTALLATION

2.1 Equipment

During unpacking, make certain that all the necessary parts have been received and that the fixture has not been damaged during transport. Should there be any problems, contact the local authorized SGM distributor immediately.

Only the customer, in fact, can claim eventual damages in the fixture caused by the transportation.

- SYNTHESIS
- WARRANTY BOOKLET
- USER MANUAL
- 1 XLR 5 P MALE CONNECTOR
- 1 XLR 5 P FEMALE CONNECTOR
- 1 POWER-CON CONNECTOR
- 2 FAST-LOCK CLAMPS
- 2 ADDITIONAL LENS
- 1 SAFETY CABLE
- 1 ANTENNA WIRELESS
- 1 OSRAM LAMP

DO NOT DESPERD THE PACKING ELEMENTS.

THE PACKING ELEMENTS (PLASTIC BAGS, FOAM, NAILS, ETC.), MUST NEVER BE LEFT NEAR CHILDREN, AS DANGEROUS. USE THE ORIGINAL PACKAGE IN CASE OF FIXTURE RETURN TO THE MANUFACTURER FOR REPAIR OR MAINTENANCE SERVICE, IT HAS BEEN SPECIFICALLY MADE TO PROTECT THE FIXTURE DURING THE TRANSPORT.

2.2 Power cable construction



Before installing the fixture check that the power supply cable AC is disconnected.

- Wiring and connection work must be carried out by experienced qualified staff.
- Class one equipment must be earthed (grounded)
- Do not power Synthesis units with dimmers, as this could damage their on-board power supply
- Before connecting the unit, make certain that the mains power supply is the same as indicated on the fixture’s ID plate
- The unit must be protected by a thermal/magnetic circuit-breaker

Symbol	Pin	EU	US	UK
L	Live	Brown	Yellow/Copper	Red
N	Neutral	Blue	Silver	Black
	Ground	Yellow/Green	Green	Green

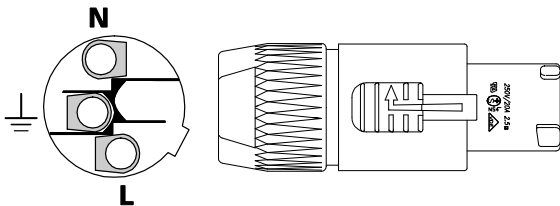

2.3 Installing the fixture on a support structure

Read the following safety information before proceeding with the installation of the fixture:



- FIXTURE NOT FOR DOMESTIC USE.
 - DO NOT INSTALL THE FIXTURE NEAR SOURCES OF HEAT.
 - INSTALL THE FIXTURE IN A WELL VENTILATED PLACE.
 - AVOID BLOCKING AIRINTAKES AND OUTPUTS.
 - DO NOT USE THE FIXTURE:
 - In places subject to vibrations or bumps
 - In place subjet to temperatures of more than 45° or less than 2°C
- AVOID ANY KIND OF DIRECT CONTACT WITH THE LAMP.



1,5m

- DO NOT PLACE THE UNIT ON INFLAMMABLE PARTS OR MATERIAL.
- PROTECT THE UNIT FROM EXCESSIVE HUMIDITY (IDEAL VALUES ARE BETWEEN 35 AND 80%).
- AVOID INFLAMMABLE LIQUIDS, WATER OR METALLIC OBJECT ENTERING THE FIXTURE.
- DON'T LIFT THE FIXTURE HOLDING IT BY THE MOVING PARTS (HEAD).
- KEEP ANY INFLAMMABLE MATERIAL AT A DISTANCE OF AT LEAST 1,5M FROM THE FIXTURE.
- POSITION THE FIXTURE AT LEAST 1,5MT FORM THE SURFACE TO BE LIT.

2.4 Positioning the fixture

Can be installed in any position.

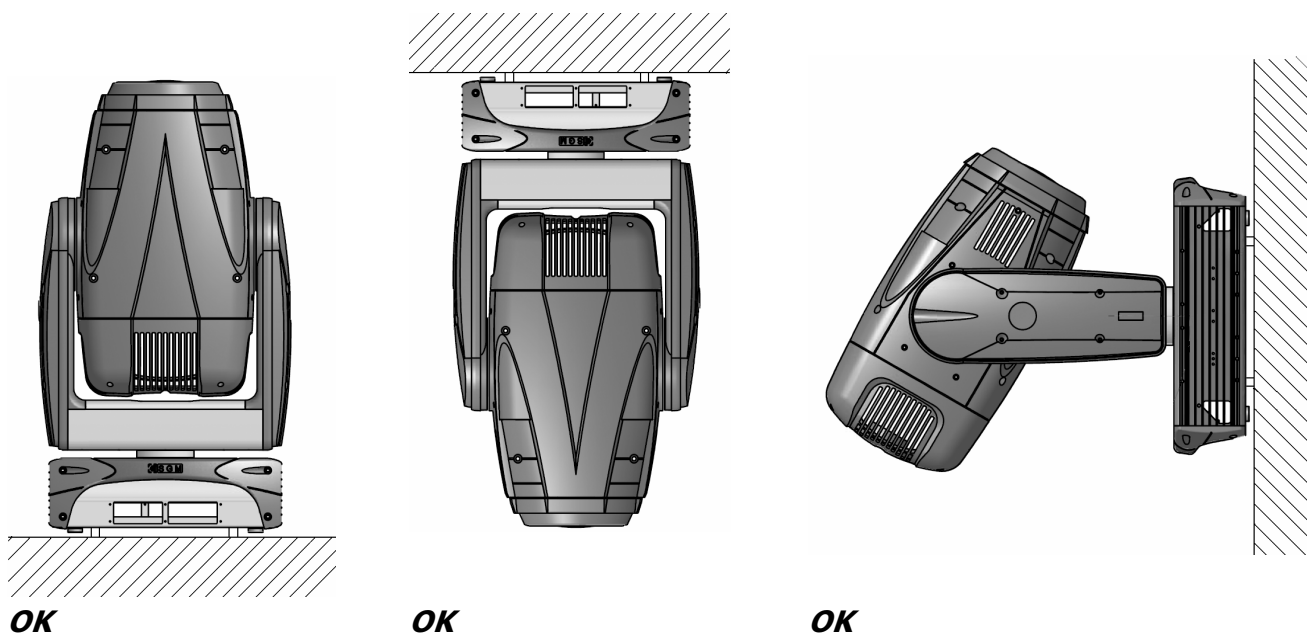

2.5 Fitting clamps

- Always use two clamps to hang the fixture.

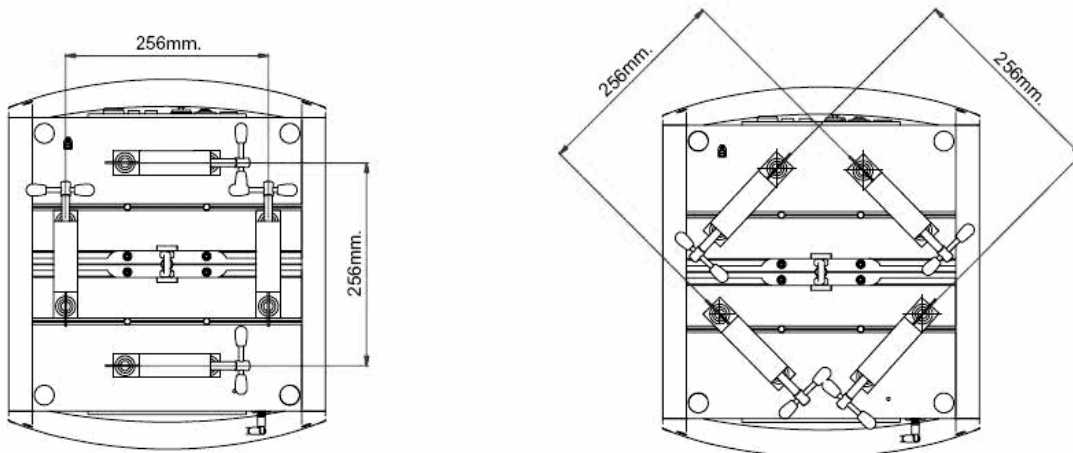

Attention: if the fixture is suspended from a truss suspended above ground or floor level, fix the fixture with a steel safety cable.

- Fix the fixture to the support structure using two safety chains fixed to the clamp (PICT. 2)
- Don't fix the safety chain to the handles, use the safety chain fixing point located in the center of the base.

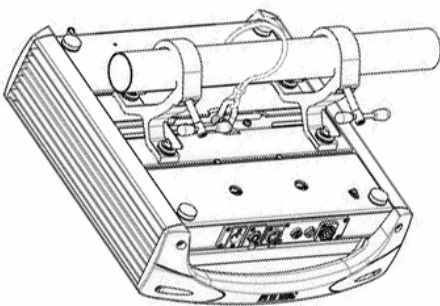

Pict. 1

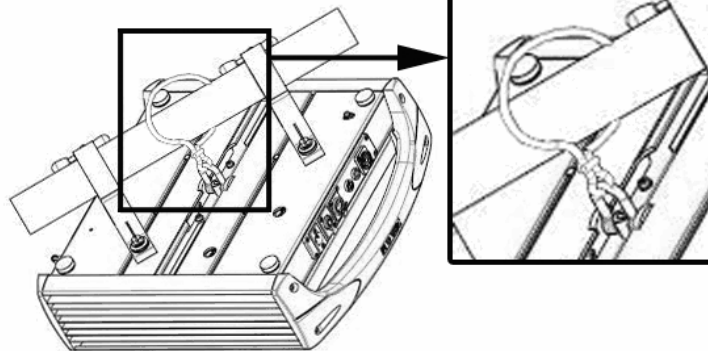

Pict. 2

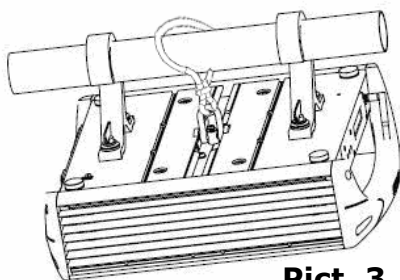

Pict. 3

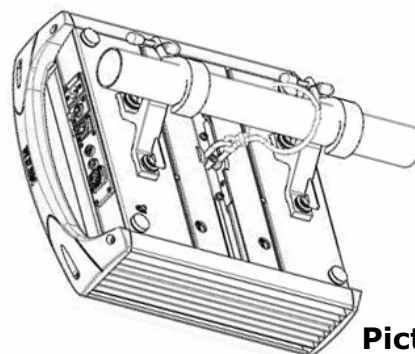

Pict. 4

CONSTRUCTION OF THE SIGNAL CABLE

Synthesis spot has a DMX 512 input fitted which uses standard XLR 5 Pins connector. For the connection use screened cables having the EIA RS-485 specifications with the following features:

- 2 conductors plus screen
- 120 ohm impedance- low capacity
- Max transmission speed 250 Kbaud.

CABLES CONNECTIONS

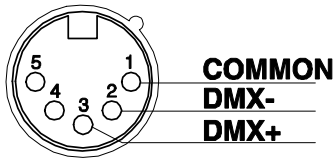

see illustration, taking care with the screen, which must be connected to Pin 1



ATTENTION!!: the screened parts of the cable (sleeve) must **NEVER** be connected to the system's earth, as this would cause faulty fixture and controller operation.

Example of connection of the DMX line:

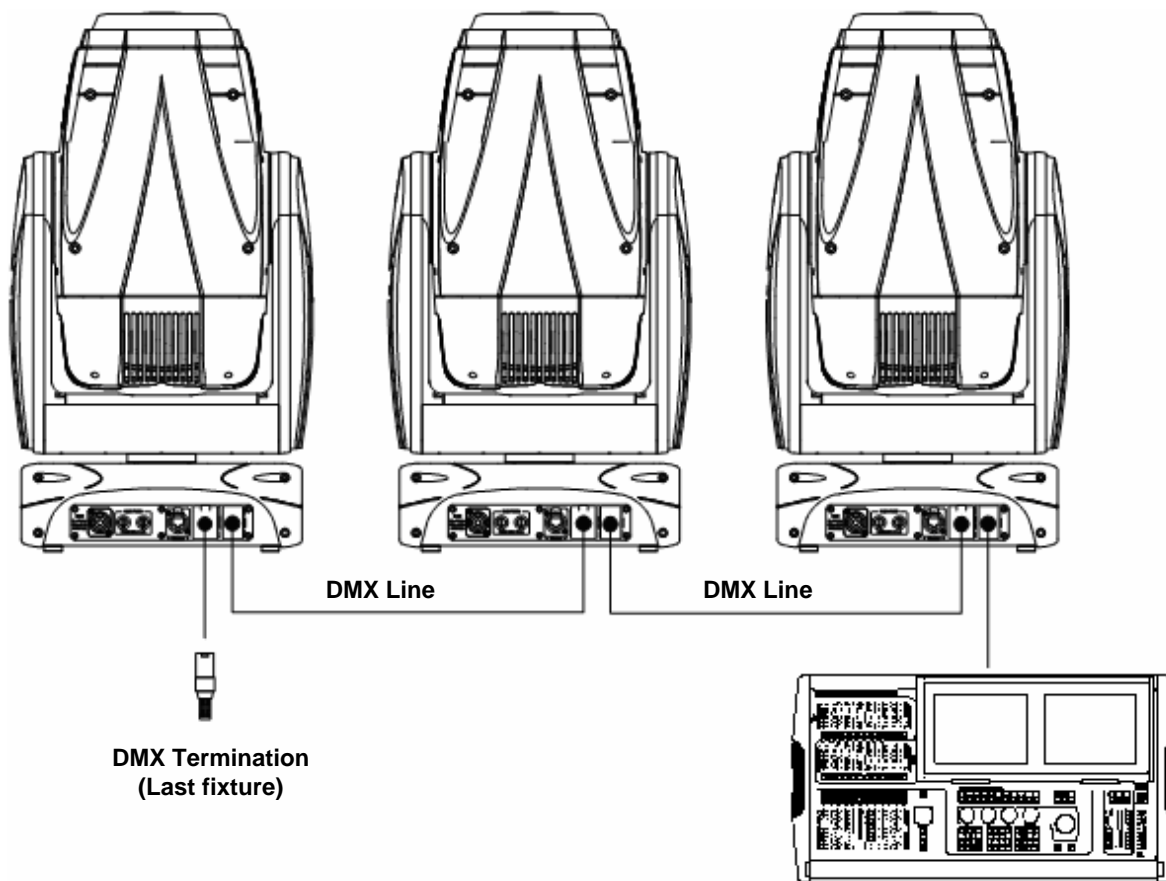

To avoid the risk of faulty operation, follow these indications:

- Maximum cable length:** 500 m
- Max. N° of fixtures connected:** 32 units
- Cable runs:** Avoid running cables alongside power supply lines.
- Termination:** A 120Ohm resistor between Pins 2 and 3 on the last fixture.

CONSTRUCTION OF THE DMX TERMINATION

The termination avoids the risk of DMX 512 signals being reflected back along the cable when they reach the end of the line:

under certain conditions and with certain cable lengths, this could cause them to cancel the original signals.

The termination is prepared by soldering a 120Ω resistor between pins 2 and 3 of the 5-pin male XLR connector (see diagram).

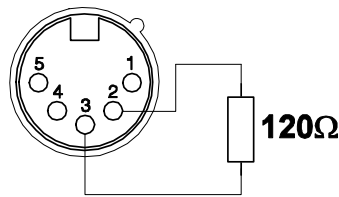

WIRELESS DMX

Synthesis is the world's first moving head fixture fitted with wireless DMX as standard. It uses a technology based on the idea of GSM, with a radius over 500 meters.

It has been widely tested in environments with WiFi, bluetooth, GPRS-UMTS signals, with excellent results.

If you want to use the wireless DMX protocol instead of the cable, proceed as follows:

- For the wireless connection you need a specific transmitter (code 0097035)
- Synthesis has 2 menus dedicated to the wireless: 1-WIRELESS LOG OFF and 2-WIRELESS
- The procedure to activate the wireless communication is very easy:
 1. Enter the LOG OFF menu and confirm the SET option. This function disables all the communications previously enabled.
 2. Set the WIRELESS on ON. This will enable a new communication.
 3. Press the LOG key on the Transmitter to connect the receiver placed on the fixture to the wireless transmitter.

RDM (REMOTE DEVICE MANAGEMENT)

RDM stands for Remote Device Management. This is the colloquial name for the ANSI E1.20 standard in development at ESTA. RDM is intended to allow bi-directional communication over the DMX512 cable. This will occur on the twisted pair connected to pins 2 and 3. This same pair of wires is used to transmit data from the console to the dimmers or moving lamps.

The large benefit of this approach as opposed to using the spare pins 4 and 5, is that RDM can be retrofitted to installations wired with single pair cable.

RDM will provide the following benefits:

1. Ability for the console to set the base address of the lamp. There will no longer be a need for DIP switches.
2. Plug and Play. The console will be able to search all the DMX512 devices and then automatically patch them.
3. Fixture Personality: it will be possible for the console to use RDM to download personalities direct from the moving lamp.
4. RDM devices can be firmware upgraded via the DMX signal.
5. RDM devices can send status and fault information back to the console.
6. By allowing bi-directional communication, it will be much easier to mix DMX installation with sophisticated Ethernet protocols such as Art-Net and ACN.

RS-232 CONNECTION

For this connection, use good quality screened coax cable (RG58 50Ohms) to avoid problems with signal transmission and faulty fixture operation. Connectors must always be 5-pin XLRs. Refer to the diagram for wiring.

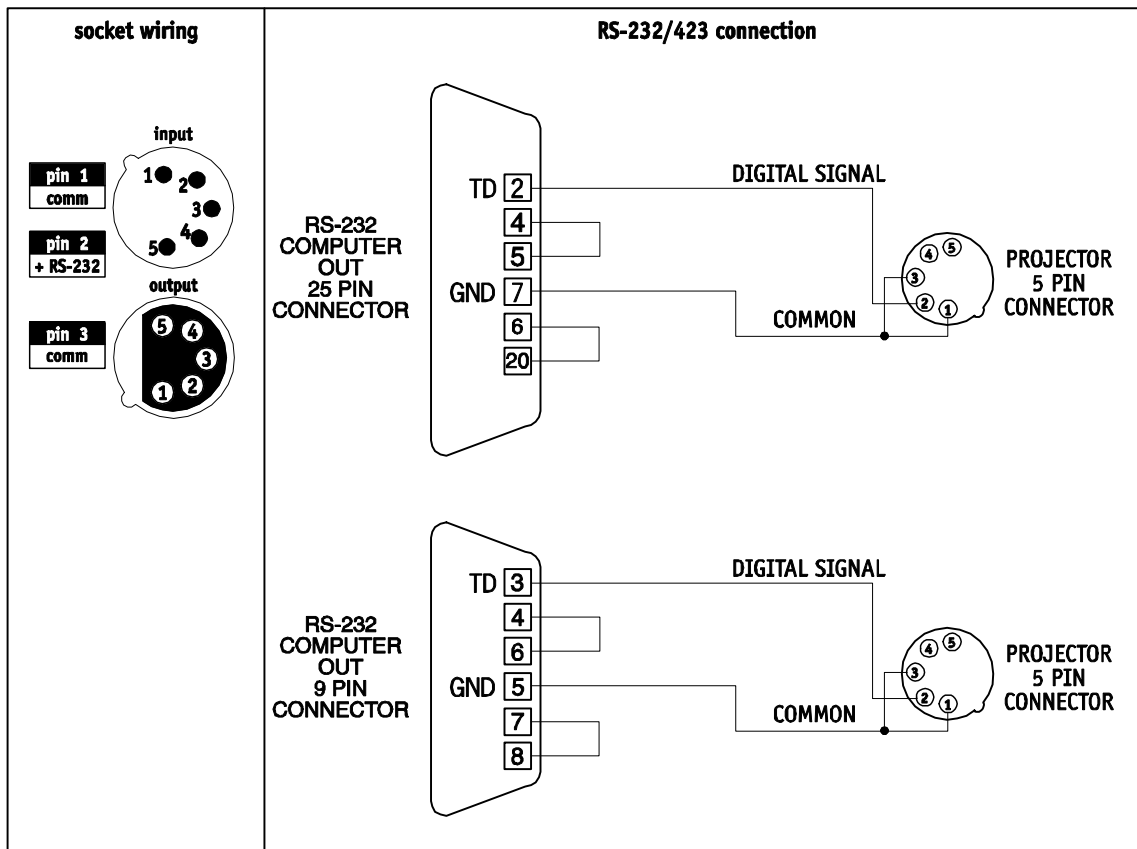

2.6 Firmware updating

To update the firmware of the fixture you need:

- USB-DMX Driver to install the new hardware.
- USB-DMX cable to connect the unit to the PC.
- Updated software version.

Please follow the below procedure to perform the updating:

1. Install the USB-DMX driver on the PC you will use to download the software. The driver and the instructions to install it will be available in our web site www.sgm.it
2. Connect the USB-DMX cable from the PC to the fixture.

3. Download the software.

The software is composed by an upd file and a file with extension .exe, by opening the file .exe the updating will be enabled automatically.

This software won't update the microprocessors of the fans boards fitted in the head, of the ballast and the PFC. It will be possible to download the software from our web site www.sgm.it.

2.7 Access to internal components

All work must **ALWAYS** be carried out by qualified technical personnel.



ATTENTION!! make certain that the fixture is switched off and that there is no risk of burns due to high component temperature (wait at least 30 minutes after switching off)

To access internal components, proceed as follows:

1. Place the head of the Synthesis in a vertical position (Fig.1)
2. Use a screwdriver to loosen screws 1, 2, 3 and 4 (Fig.1)
3. Extract the cover "A" (Fig.2) outwards.

If necessary, repeat the same procedure for cover "B"

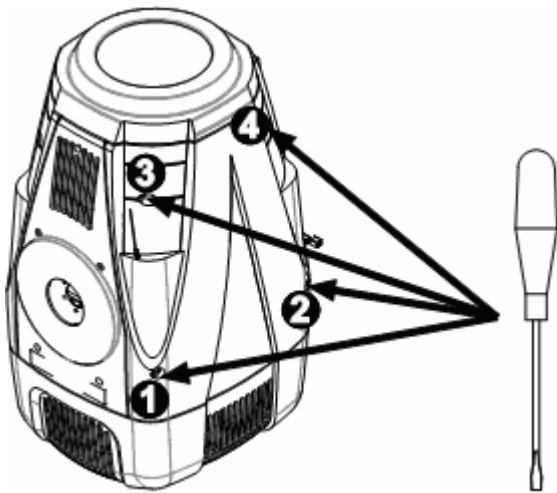

Pict. 1

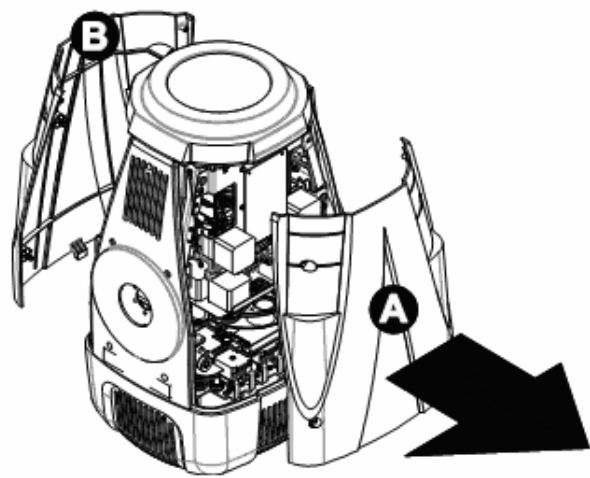

Pict. 2

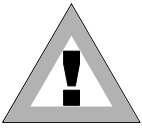
INSTALLING / REPLACING THE LAMP

ATTENTION! This fixture is designed exclusively for use with Osram HTI 700W/SE/75 lamps. NEVER USE ANY OTHER TYPES OF LAMPS.

DISCONNECT THE POWER SUPPLY BEFORE CARRYING OUT ANY WORK ON THE FIXTURE.

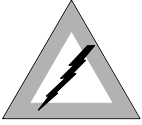

MAKE CERTAIN THAT THE FIXTURE IS OFF AND THE TEMPERATURE OF THE COMPONENTS CAN'T CAUSE BURNS (**WAIT AT LEAST 30 MINUTES AFTER SWITCHING OFF**).

NEVER CARRY OUT ANY WORK IF THE FIXTURE DOESN'T HAVE ITS PROTECTIVE COVERS OR ITS LENSES ARE DAMAGED. DISCHARGE LAMPS CAN EXPLODE.



NEVER LOOK DIRECTLY AT THE LAMP WHEN IT'S LIT - DISCHARGE LAMPS EMIT UV RAYS WHICH ARE DANGEROUS FOR SIGHT.

Inside the fixture's moving head, there is an optical system. Follow the herebelow instructions when installing or replacing a lamp.

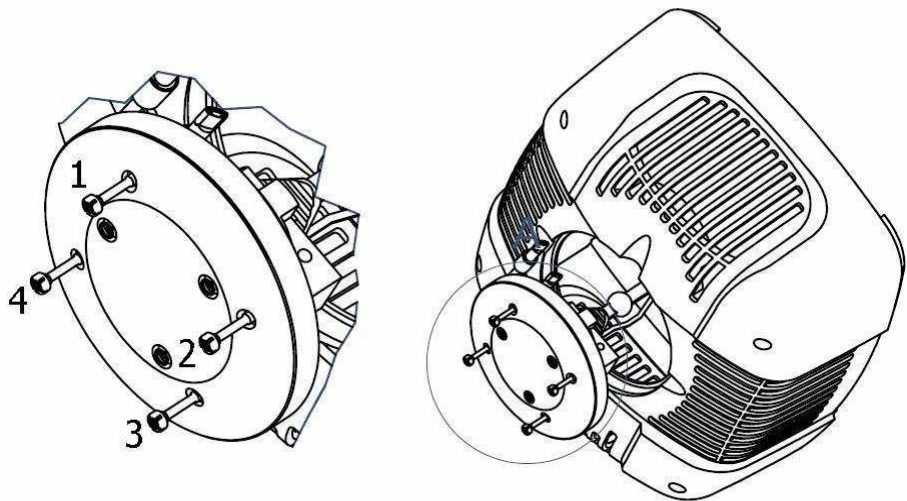
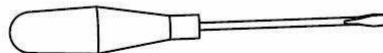
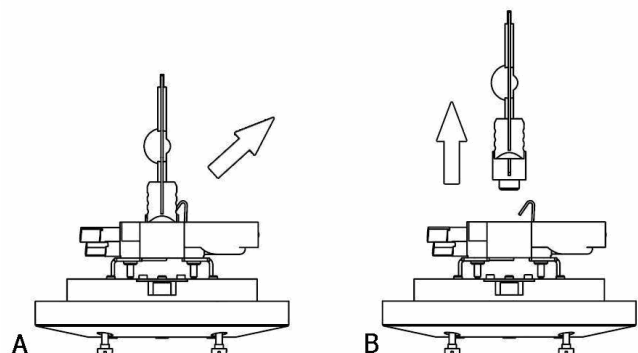
**Pict. 1****Pict. 2****Pict. 3**

1. Through a screwdriver untighten the screws indicated in picture 1 with numbers 1.2.3.4.
2. Remove the rear cover where the socket is located, as indicated in picture 2.
3. Pull the lamp fixing spring as indicated in picture 3 and at the same time remove the lamp from the lamp holder as indicated in picture 3B.
4. Never touch the lamp bulb bare handed. Always use a cloth or gloves to handle the lamp during insertion or removal operations.

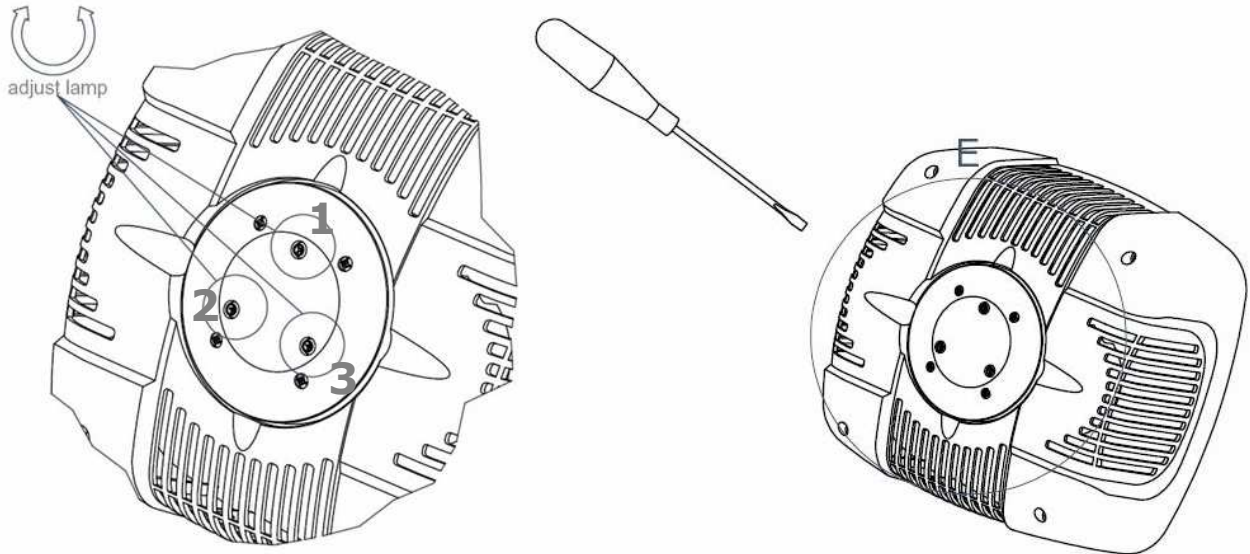
LAMP ALIGNMENT

When replacing the lamp with a new one, align the lamp with the optical system to obtain the max uniformity and luminous performance by the projection.

1. Install the new lamp close the fixture and switch it on
2. Connect the fixture to a lighting console.
3. Point the fixture at a flat surface (if possible white or light colored) at least three metres from the fixture.
4. Set the control channels to obtain a white beam. Then open the IRIS, set the DIMMER fully open, FUOCO correctly and do not project GOBOS or COLORS.
5. Use screws 1, 2 and-3 to align the lamp until an evenly projected light beam is obtained, with no shadows or zones which are brighter than others.

INSTALLING / REPLACING GOBOS

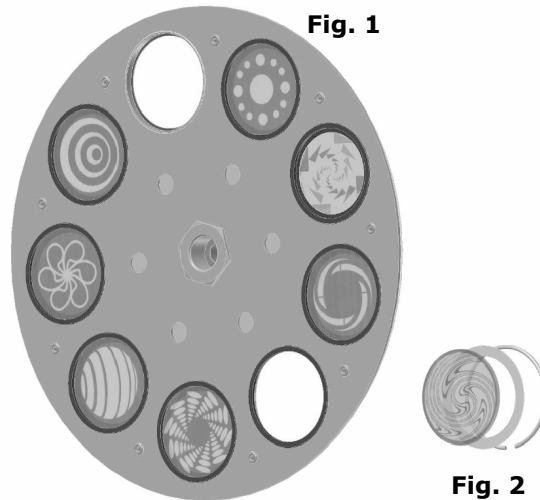

METAL: Once opened the fixture choose which of the gobos is to be replaced, gently press in order to remove the spring and the gobos, paying attention that they don't fall into fixture. Insert the new gobo, the ring and the fixing spring pict. 2.

DICRO: Once opened the fixture choose which of the gobos is to be replaced, gently press in order to remove the spring, the ring and the gobo, paying attention that they don't fall into fixture. Insert the new gobo, the ring and the fixing spring pict. 2.

INSTALLING / REPLACING THE ANIMATION WHEEL

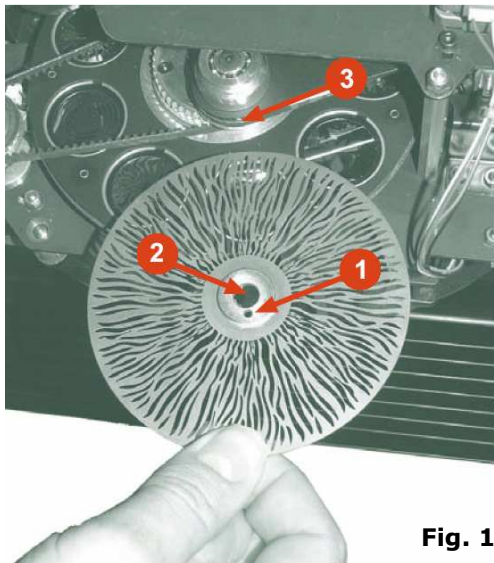

Fig. 1

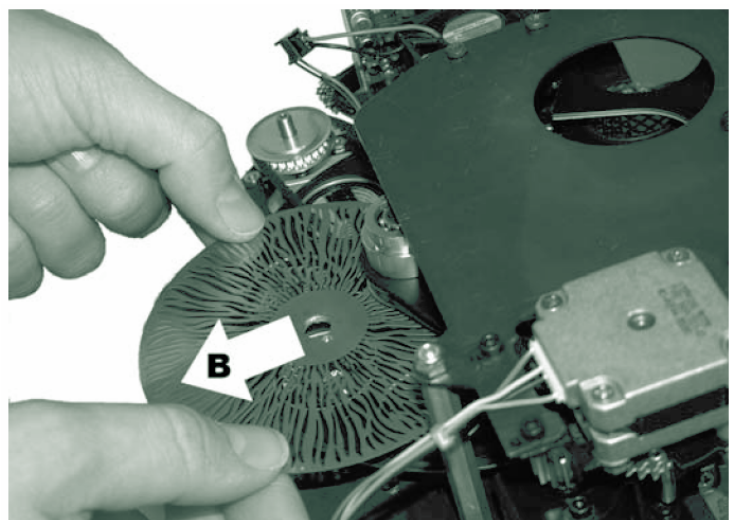
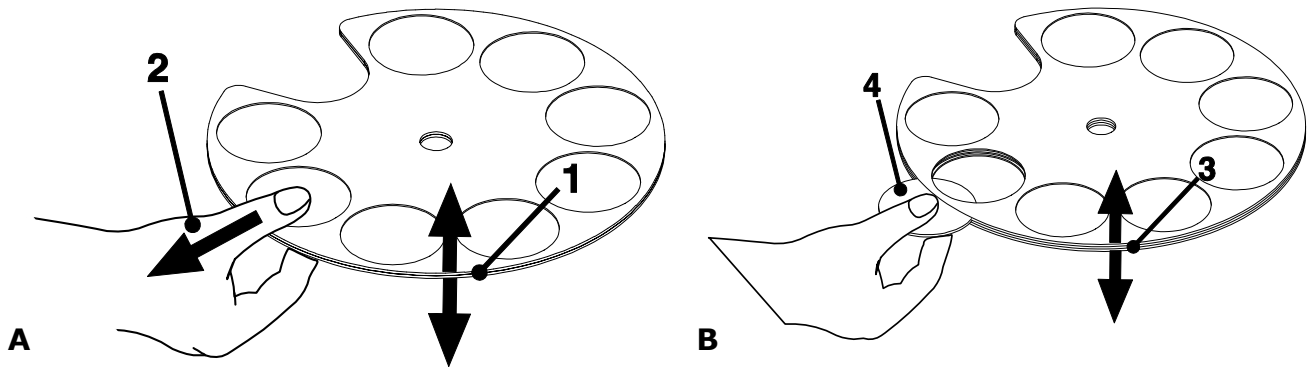

Fig. 2

REMOVAL: Grip the Animation wheel with both the hands, gently press towards the bottom and at the same time extract the wheel (see arrow "B" Pict.2)

INSTALLATION: Repete the operations in the contrary order, carefully aligning the hole "1"(Pict.1) to the plug.

INSTALLING / REPLACING THE COLOR FILTERS

Choose, in the color or effect wheel, which dichroic filters is to be replaced.

Color filter removal:

- 1) Widen the disks fitted in the color wheel as indicated in picture A1
- 2) Grip the dichroic filter between your fingers and slide the filter out as indicated in picture A2.

Installation of the new color filter:

- 1) Carefully widen the disks again as indicated in picture B3.
- 2) Slide in the new color filter until it fits into its engraved slot as indicated in pict. B4.

3 MICRO COMPUTER CONTROL



3.1 Microcomputer "Control"

Synthesis is fitted with a microcomputer that enables the best fixture customization to the type of installation. It is possible:

- To assign the starting address
- Receive data on lamp elapsed time and fixture operating time
- Run diagnostic checks controlling the correct functioning of the fixture
- Customization of some of the parameters

3.2 Longlife rechargeable buffer battery

Synthesis Microcomputer is also powered by an internal buffer battery which enables to use the display functions even by not powered fixture. For powering the display from the battery, press the enter key for some seconds and the display will switch on automatically.

3.3 Navigating the menu

When it's switched on, the fixture runs a start-up reset procedure and the display indicates if there's an input signal or not.

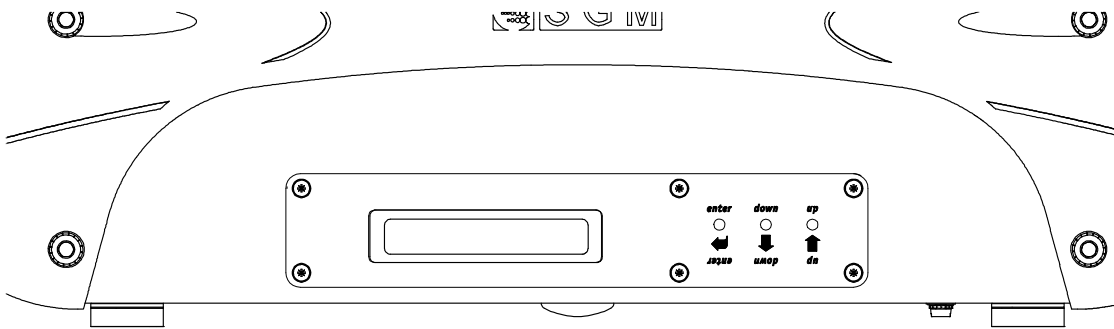

The 3 keys under the display are for selecting and using the various submenus which make up the main menu.

- **UP/DOWN** keys: used to scroll the various items in the menu. In the selected menu, used to change the required parameters.

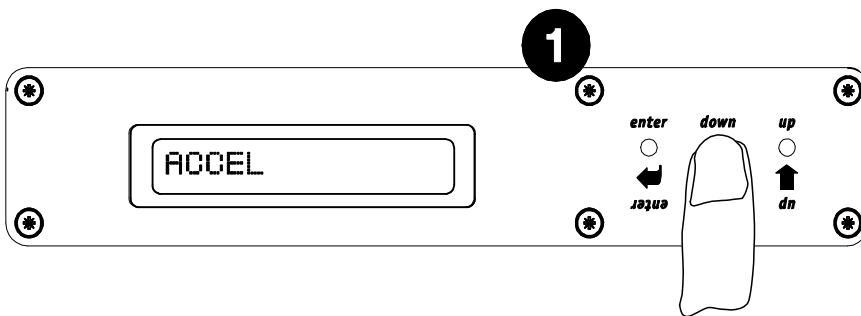

- **ENTER** key: used to access to the selected menu and, once the necessary changes have been made, is used to confirm them.

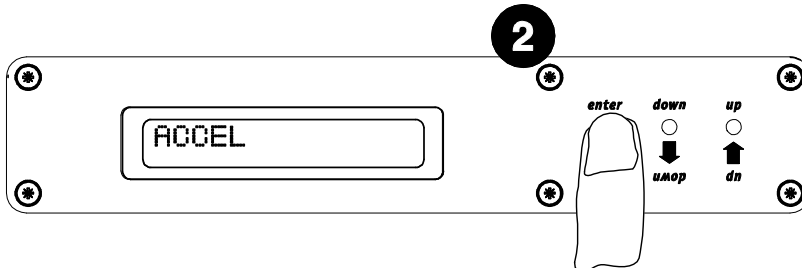

3.4 Structure of the menu

Here below are indicated the options composing Synthesis menu.

Menu	Options	Description
ADDRESS XXX	Range 001-456	Fixture addressing
PAN MOVE	NORMAL	Normal PAN control of left to right PAN movement.
	REVERSE	Inverted PAN movement control (from right to left).
PAN POS MIN	Range 000-526	Sets PAN movement start position. Default configuration = 000 degrees
PAN POS MAX	Range 004-530	Sets PAN movement stop position. Default configuration = 530 degrees
TILT MOVE	NORMAL	Normal control of TILT from up to down.
	REVERSE	Inverted TILT movement control (from down to up).
TILT POS MIN	Range 000-246	Sets TILT movement start position. Default configuration = 000 degrees
TILT POS MAX	Range 004-250	Sets TILT movement stop position. Default configuration = 250 degrees
PAN TILT SWAP	ON	Data regarding Pan controls Tilt and vice versa.
	OFF	Normal control of Pan and Tilt movement.
LAMP HOUR	-	Read only Menu. Stores lamp elapsed time. Can be reset.
LAMP STRIKE	-	Read only Menu. Stores the number of lamp strike. Can be reset.
SCANNER HOUR	-	Read only Menu. Stores fixture operating time.
SIGNAL	DMX	DMX signal selected. Automatic selection of the signal.
	RS-232	RS-232 signal selected. Automatic selection of the signal.
WIRELESS	ON	Enables the DMX WIRELESS
	OFF	Disable the DMX WIRELESS.
WIRELESS LOGOFF	SET	Disable the previous WIRELESS setting.
PAN TILT RES	16 bit	bitEnable the Pan\Tilt movement resolution 16 bit.
	8 bit	bitEnable the Pan\Tilt movement resolution 8 bit.
OPERATING	HIGH RES	Enable Focus and Gobos index 16 bit.
	LOW RES	Enable Focus and Gobos index 8 bit, reducing the channels total number.
SPEED CONTROL	TRACKING	Traking operating mode. Mspeed channel is disabled.
	VECTOR	Vector operating mode. Mspeed channel is enabled.
LAMP CONTROL	ENABLE	Remote lamp ignition enabled.
	DISABLE	Remote lamp ignition disabled.
RESET CONTROL	ENABLE	Remote reset enabled.
	DISABLE	Remote reset disabled.
SPEED	100% - 92% 84% - 76%	Allows to slow maximum Pan and Tilt speed. Default configuration = 100%
ACCELERATION	Fast	Optimises speed performance.
	Slow	Optimises smooth movement.
BRIGHTNESS	100-53-40-27 20-13-6-0(%)	Allows adjustment of display brightness. Default configuration =40%
DISPAY FLIP	-	Inverts display reading position. Used according to the position in which the fixture is installed.
DMX DELAY	Range 8-600sec	It's possible to set the number of second for which the fixture's last operating status must be held when there is no DMX signal.
	UNL	Always maintains the fixture's last operating status no matter for how long there is no DMX signal.
SHUTTER CLOSE	SHUTTER CLOSE=DS	Disables shutter closure in the event of pan/tilt loss of position.
	SHUTTER COLOSE=EN	Enables shutter closure in the event of pan/tilt loss of position.
FACTORY	FACTORY=SET	Enables to set default parameters.
	FACTORY=OFF	Value during normal operation.
PREVIOUS	PREVIOUS=SET	Enables to restore the values of the parameters set immediately before FACT=SET procedure.
	PREVIOUS=OFF	PREV value during normal operation.

SETTING	-	Reserved Menu, access by password. Enable the calibration of movement mechanical components (gobo wheels; color).
TEST	TEST=RESET	SET of the Fixture.
	TEST=ALL	Run the test of all the effects in sequence.
	TEST=PAN	Run PAN test.
	TEST=TILT	Run TILT test.
	TEST=IRIS	Run IRIS test.
	TEST=COLOR	Run the color wheel test.
	TEST=GOBO1	Run the gobo1 wheel test.
	TEST=GOBO2	Run the gobo2 wheel test.
	TEST=RGBOB1	Run the gobo1 rotation test.
	TEST=RGBOB2	Run the gobo2 rotation test.
	TEST=SHUTT	Shutter test.
	TEST=DIMM	Dimmer test.
	TEST=FROST	Frost test.
	TEST=PRISM	Prisms test.
	TEST=FOCUS	Focus tests.
	TEST=ZOOM	Zoom test.
	TEST=GSHAKE1	Goboshake gobo1 wheel test.
	TEST=GSHAKE2	Goboshake gobo2 wheel test.
	TEST=ANWHE	CTO test.
	TEST=CYANO	Cyan wheel test.
TEST=MAGEN	Magenta wheel test.	
TEST=YELLW	Yellow wheel test.	
TEST=CTO	CTO test.	
RESERVED	-	-
TEMPERATURE	INPUT °C	Shows the temperature of the input board in centigrade degrees.
	INPUT °F	Shows the temperature of the input board in Fahrenheit degrees.
	PAN °C	Shows the temperature of the the pan Control board in in centigrade degrees.
	PAN °F	Shows the temperature of the the pan Control board in Fahrenheit degrees.
	TILT °C	Shows the temperature of the the tilt Control board in centigrade degrees.
	TILT °F	Shows the temperature of the the tilt Control board in Fahrenheit degrees.
	GOBO °C	Shows the temperature of gobo module Control board in centigrade degrees.
	GOBO °F	Shows the temperature of gobo module Control board in Fahrenheit degrees.
	ZOOM °C	Shows the temperature of the zoom Control board in centigrade degrees.
	ZOOM °F	Shows the temperature of the zoom Control board in Fahrenheit degrees.
	CMY °C	Shows the temperature of the CMY Control board in centigrade degrees.
	CMY °F	Shows the temperature of the CMY Control board in Fahrenheit degrees.
	HEAD °C	Shows the temperature of the head fans Control in centigrade degrees.
	HEAD °F	Shows the temperature of the head fans Control in Fahrenheit degrees.
	LAMP °C	Shows the temperature of the Lamp heat sink Plate in centigrade degrees.
	LAMP °F	Shows the temperature of the Lamp heat sink Plate in Fahrenheit degrees.
	BASE °C	Shows the temperature of the Ballast board in centigrade degrees.
	BASE °F	Shows the temperature of the Ballast board in Fahrenheit degrees.
POWER °C	Shows the temperature of the PFC board in centigrade degrees.	
POWER °F	Shows the temperature of the PFC board in Fahrenheit degrees.	

VERSION	INPUT	1.0	Shows the Processor-in board software version.
	PAN	1.0	Shows the Processor-pan board software version.
	TILT	1.0	Shows the Processor-tilt board software version.
	GOBO	1.0	Shows the Processor-gobo board software version.
	ZOOM	1.0	Shows the Processor-zoom board software version.
	CMY	1.0	Shows the CMY board software version.
ADDR 100			Message shown by the display in fixture normal working condition (i.e. 100 is the DMX 512 channel on which the first unit is set)

Allocating the first addressed channel / Addressing

ADDRESS=XXX

In order to receive the commands necessary to operate from a lighting console, each fixture has to be allocated a start address. This address normally indicates the first channel used (start channel) and can be allocated following a different way from that used to connect the signal line. Synthesis uses a number of channels included between 35 and 31, depending on the set operating mode. so during allocation, this quantity must be kept in mind to avoid possible overlapping of other fixtures' channels.

HRV(35Ch)		HRT(34Ch)		LRV(32Ch)		LRT(31Ch)	
FIXTURE N°	STARTING ADDRESS	FIXTURE N°	STARTING ADDRESS	FIXTURE N°	STARTING ADDRESS	FIXTURE N°	STARTING ADDRESS
1	001	1	001	1	001	1	001
2	036	2	035	2	033	2	032
3	071	3	069	3	065	3	063
4	106	4	103	4	097	4	094
5	141	5	137	5	132	5	125
6	176	6	171	6	167	6	156
7	211	7	205	7	199	7	187
8	246	8	239	8	231	8	218
9	281	9	273	9	263	9	249
10	316	10	307	10	295	10	280
11	351	11	341	11	327	11	311
12	386	12	375	12	359	12	342
13	421	13	409	13	391	13	373
14	456	14	443	14	423	14	404
		15	477	15	455	15	435
						16	466

Direction of Pan movement

PAN MOVE =000

This function allows to decide the direction in which the Synthesis moving head pans indispensable when several fixtures are installed in order that fixtures installed opposite each other move in the same direction when they receive a command.

To modify Pan movement, proceed as follows:

1. Connect Synthesis to the power supply, wait till it has completed reset operations.
2. Use the UP/DOWN keys to find the "Pan Move" menu.
3. Press ENTER to confirm. The message on the display will start to flash.
4. Use the UP/DOWN keys to select which of the two available options is required.
5. Press Enter to confirm.

Setting Pan movement starting angle

PAN POS MIN=000

Synthesis has a Pan movement range of 530°. If the entire excursion doesn't have to be used, two parameters allow to set the starting angle (MIN) and ending angle (MAX), which is 4°. To limit pan movement, proceed as follows:

PAN POS MAX=004

1. Connect Synthesis to the power supply, wait till it has completed reset operations.
2. Use the UP/DOWN keys to find the "Pan Pos Min" menu if the starting angle has to be modified. If the ending angle has to be modified, find the "Pan Position Max" menu. It is not necessary to use the max excursion, two parameters allow to limit the starting angle (Pan Position Min) and the ending angle (Pan Position Max).
3. Press Enter to confirm. The message on the display will start to flash.
4. Use the UP/DOWN keys to select the new starting (or ending) angle.
5. Press Enter to confirm.

Direction of Tilt movement

TILT MOVE=NORM

This function allows to decide the direction in which Synthesis moving heads tilts, indispensable when several fixtures indispensable are installed in order that fixtures installed opposite each other move in the same direction when they receive a command.

To modify Pan movement, proceed as follows:

1. Connect Synthesis to the power supply, wait till it has completed reset operations.
2. Use the UP/DOWN keys to find the "Tilt Move" menu
3. Press ENTER to confirm. The message on the display will start to flash.
4. Use the UP/DOWN keys to select which of the two available options is required.
5. Press Enter to confirm.

Limiting Tilt movement

TILT POS MIN=000

Synthesis has a Tilt movement range of 250°. If the entire excursion doesn't have to be used, two parameters allow to limit the starting angle (Tilt Pos Min) and the ending angle (Tilt Pos Max). The only limit is the minimum difference between starting (MIN) and ending (MAX), which is 4°.

TILT POS MAX=004

To limit the tilt movement proceed as follows:

1. Connect Synthesis to the power supply, wait till it has completed reset operations.
2. Use the UP/DOWN keys to find the "Tilt Pos Min" menu if the starting angle has to be modified. If the ending angle has to be modified, find the "Tilt Pos Max" menu. It is not necessary to use the max excursion, two parameters allow to limit the starting angle (Tilt Pos Min) and the ending angle (Tilt Pos Max).
3. Press ENTER to confirm. The message on the display will start to flash.
4. Use the UP/DOWN keys to select the new starting (or ending) angle
5. Press Enter to confirm.

Pan/Tilt inversion

PAN TILT SWAP=OFF

This function also allows to optimize Synthesis moving head in relation to the operator's position, in order to simplify all positioning procedure. When SWAP is enabled (ON), this means that the lighting console sends the data regarding Pan to the Tilts controls and vice versa.

To invert Pan and Tilt movement proceed as follows:

1. Connect Synthesis to the power supply, wait till it has completed reset operations.
2. Use the UP/DOWN keys to find the "PAN TILT SWAP" menu.
3. Press ENTER to confirm. The message on the display will start to flash.
4. Use the UP/DOWN keys to select which of the two available options is required
5. Press Enter to confirm.

Lamp elapsed time meter

LAMP HOUR

Synthesis microcomputer stores various data, including those related to the number of hours the lamp is lit (elapsed time). This is necessary to know in advance when it's almost time of relamping: lamp life is approximately 750 hours.

To see how many hours a lamp has been used, proceed as follows:

1. Connect Synthesis to the power supply, wait till it has completed reset operations.
2. Use the UP/DOWN keys to find the "Lamp Hour" menu. The lamp life hours will be displayed automatically.

Resetting the lamp elapsed time meter

LAMP HOUR

Each time a new lamp is fitted it's possible to reset the meter indicating the elapsed time in order to have the real elapsed time for the lamp about to be fitted.

To reset the lamp elapsed time, proceed as follows:

1. Connect Synthesis to the power supply, wait till it has completed reset operations
2. Use the UP/DOWN keys to find the "Lamp Hour" menu.
3. Press ENTER to confirm. The message on the display will start to flash.
3. Use the DOWN key to reset the meter.
4. On the contrary, pressing the UP key restores the previous value.
5. Press Enter to confirm.

Lamp strike meter

LAMP STRIKE

Synthesis microcomputer stores various data, including those related to the number of lamp strikes. This information is important because the 'unuseful' lamp strikes cause stress to the components, so they can contribute to reduce the lamp life.

To know the lamp strikes number:

1. Connect Synthesis to the power supply, wait till it has completed reset operations.
2. Use the UP/DOWN keys to find the "Lamp Strike" menu. The strikes number will be displayed automatically.

Resetting the lamp strike meter

LAMP STRIKE

Each time the fixture is relamped, it is possible to reset the lamp strike meter which counts the strikes, in order to have number of actual strikes for the lamp about to be installed.

To reset the lamp strike meter, proceed as follows:

1. Connect Synthesis to the power supply, wait till it has completed reset operations.
2. Use the UP/DOWN keys to find the "Lamp Strike" menu
3. Press ENTER to confirm. The message on the display will start to flash.
4. Use the DOWN key to reset the meter.
5. On the contrary, pressing the UP key restores the previous value.
6. Press Enter to confirm.

Fixture operating time meter

SCANNER HOUR

This function allows to see for how many hours the fixture has been operating. This meter cannot be reset.

To see how many hours the fixture has been used, proceed as follows:

1. Connect Synthesis to the power supply, wait till it has completed reset operations.
2. Use the UP/DOWN keys to find the "Scanner Hour" menu. The fixture life hours will be displayed automatically.

Input signal

SIGNAL=DMX

This menu is only for reading and allows to verify which type of input signal is used (DMX or RS232). The signal is automatically recognized.

To visualize the required signal, proceed as follows:

1. Connect Synthesis to the power supply, wait till it has completed reset operations.
2. Use the UP/DOWN keys to find the "Sign=DMX" menu.
3. The display will show the signal used.

Pan/Tilt movement resolution

PAN TILT RES

This function allows to define the movement resolution (16 or 8 bit). The difference is in the number of steps in which the range of head movement is divided.

In high res. (16bit) mode, 530° of pan and 250° of tilt are divided into 65.536 steps, ensuring very smooth precision even at very low speed. In low res. (8 bit) mode the number of the steps is 256, which nevertheless allow precise movement. The change from high res. into low res. reduces the number of channels.

1. Connect Synthesis to the power supply, wait till it has completed reset operations.
2. Use the UP/DOWN keys to find the "Pan Tilt Res" menu.
3. Press ENTER to confirm. The message on the display will start to flash.
4. Use the UP/DOWN keys to select the required resolution.
5. Press Enter to confirm.

Wireless

WIRELESS

Synthesis Spot is the first fixture worldwide to be fitted with the DMX Wireless connection as standard. It uses a technology based on the idea of GSM, with a radius over 500 meters. It has been widely tested in environments with WiFi, bluetooth, GPRS-UMTS signals, with excellent results.

To enable the wireless communication proceed as follows:

- Synthesis has two menu for the: 1-WIRELESS LOG OFF and 2-WIRELESS.
- The procedure to activate the wireless communication is very easy:
 1. Enter the LOG OFF menu and confirm the SET option. This function disables all the communications previously activated.
 2. Set the WIRELESS menu on ON. This will enable a new communication.
 3. Press the LOG key on the Transmitter to connect the receiver located on the fixture.

Wireless logoff

WIRELESS LOGOFF

This function allows to disable all the wireless communication previously activated.

To enable the LOGOFF, proceed as follows:

1. Connect Synthesis to the power supply, wait till it has completed reset operations.
2. Use the UP/DOWN keys to find the "WIRELESS LOGOFF" menu.
3. Press ENTER to confirm. The message on the display will start to flash.
4. Use the UP/DOWN keys to confirm the SET option.
5. At this point Synthesis is set for a WIRELESS communication.

Operating

OPERATING

This function allows to define the resolution of the 8-16 bit movement for the FOCUS control channel and the indexing channels of the GOBO1 and GOBO2 wheels.

The difference is in the steps number in which the range of movement of these channels has to be divided. In 16 bit mode the range of movement or indexing is divided into 65.536 steps, allowing absolutely smooth and precise slow movements. The 8 bit mode allows also a good smoothness and precision on a number of 256 steps. To modify the settings, proceed as follows:

1. Connect Synthesis to the power supply, wait till it has completed reset operations.
2. Use the UP/DOWN keys to find the "OPERATING" menu.
3. Press ENTER to confirm. The message on the display will start to flash.
4. Use the UP/DOWN keys to select the required resolution HIGH RES for 16 bit mode, LOW RES for 8 bit mode.
5. Press Enter to confirm.

Speed Control

SPEED CONTROL

There are two ways to control the speed with which a fixture moves from a static position into another. These are known with the names of "TRACKING control" and "VECTOR control" and are determined by the presence of the Pan/Tilt Speed channel. In TRACKING mode the speed is determined by the cross-fade time set on the console. In VECTOR mode the speed is set by the Pan/Tilt Speed channel directly, the cross-fade time in the console has to be 0.

To modify the settings, proceed as follows:

1. Connect Synthesis to the power supply, wait till it has completed reset operations.
2. Use the UP/DOWN keys to find the "SPEED CONTROL" menu.
3. Press ENTER to confirm. The message on the display will start to flash.
4. Use the UP/DOWN keys to select the required control speed.
5. Press Enter to confirm.

Remote control lamp ignition

LAMP CONTROL=DS

Operators can decide if the ignition of Synthesis is to be controlled from a lighting console or be automatic.

To access this function, proceed as follows:

1. Connect Synthesis to the power supply, wait till it has completed reset operations.
2. Use the UP/DOWN keys to find the "LAMP CONTROL" menu.
3. Press ENTER to confirm. The message on the display will start to flash.
4. Use the UP/DOWN keys to select the option decided.
5. Press ENTER to confirm.

Remote control of fixture reset

RESET CONTROL

Using this menu, it's possible to decide whether to reset the fixture via remote control or not.

To enable this function, proceed as follows:

1. Connect Synthesis to the power supply, wait till it has completed reset operations.
2. Use the UP/DOWN keys to find the "RESET CONTROL" menu.
3. Press ENTER to confirm. The message on the display will start to flash.
4. Use the UP/DOWN keys to select the option decided.
5. Press ENTER to confirm.

Control of the acceleration of movement speed

SPEED=100%

Movement can be optimized by changing the speed (SPEED) and acceleration (ACCEL) parameters, obtaining smooth fast or slow movements as required.

To optimize movement, proceed as follows:

ACCELERATION=FAST

1. Connect Synthesis to the power supply, wait till it has completed reset operations.
2. Use the UP/DOWN keys to find the "SPEED" or "ACCELERATION" menu.
3. Press ENTER to confirm. The message on the display will start to flash.
4. Use the UP/DOWN keys to select the option decided.
5. Press ENTER to confirm.

Display brightness

BRIGHTNESS=40%

Operators can select one of the brightness levels available for Synthesis display, which can be standard or very low. This option is intended for theatre and television use, where excessive brightness can be troublesome.

To change display brightness:

1. Connect Synthesis to the power supply, wait till it has completed reset operations.
2. Use the UP/DOWN keys to find the "BRIGHTNESS" menu.
3. Press ENTER to confirm. The message on the display will start to flash.
4. Use the UP/DOWN keys to select the option decided.
5. Press ENTER to confirm.

Display reading position

DISPLAY FLIP

When the fixture is mounted "upside down" on a structure, operators can turn the display through 180°, thus greatly facilitating the reading of the menus on the display. To change the reading position, proceed as follows:

1. Connect Synthesis to the power supply, wait till it has completed reset operations.
2. Use the UP/DOWN keys to find the "DISPLAY FLIP" menu.
3. Press ENTER to confirm. The message on the display will start to flash.
4. Use the UP/DOWN keys to select the option decided.
5. Press ENTER to confirm.
6. Another rapid way to modify the display reading position is to press for some seconds the UP/DOWN keys at the same time.

dmx delay

DMX DELAY= UNL

This allows to set for how many seconds the fixture’s last operation settings are maintained when the DMX signal is missing. This function is indispensable in those cases in which there is an accidental DMX failure.

To set the required time, proceed as follows:

1. Connect Synthesis to the power supply, wait till it has completed reset operations.
2. Use the UP/DOWN keys to find the “DMX DELAY” delay
3. Press ENTER to confirm. The message on the display will start to flash.
4. Use the UP/DOWN keys to select the option decided. If UNL(unlimited) value is set, the fixture keeps the last operating condition valid independently from the time of missing DMX.
5. Press ENTER to confirm.

Locking/Unlocking the shutter

SHUTTER CLOSE=EN

This feature allows to disable or enable Shutter closure if Pan or TILT loose their position.

SHUTTER CLOSE=DS

1. Connect Synthesis to the power supply, wait till it has completed reset operations.
2. Use the UP/DOWN keys to find the “SHUTTER CLOSE”menu.
3. Press ENTER for some seconds to confirm. The message on the display will start to flash.
4. Use the UP/DOWN keys to select the voice “SHUTTER CLOSE=ENABLE ” or “SHUTTER CLOSE=DISABLE” to enable or disable the shutter in case of loss of position
5. Press ENTER to confirm.

Setting default parameters

FACTORY=SET

This feature allows to set the default parameters:

1. Connect Synthesis to the power supply, wait till it has completed reset operations.
2. Use the UP/DOWN keys to find the “FACTORY” menu.
3. Press ENTER to confirm. The message on the display will start to flash.

Use the UP/DOWN keys to select “FACTORY=SET” and press “Enter” key.

4. Press “Enter” key to set the default parameters indicated in the table, at this point the display will show “FACTORY=OFF”.

FACTORY=OFF

Voce Menu	Parametro Default
ADDRESS	001
PAN MOVE	NORM
PAN POS MIN	000° gradi
PAN POS MAX	530° gradi
TILT MOVE	NORM
TILT POS MIN	000° gradi
TILT POS MAX	250° gradi
PAN TILT SWAP	OFF
SIGNAL	DMX
WIRELESS	OFF
WIRELESS LOGOFF	OFF
PAN TILT	16 bit
OPERATING	HIGH RES
SPEED CONTROL	VECTOR
LAMP CONTROL	DISABLE
RESET CONTROL	ENABLE
SPEED	100%
ACCELERATION	FAST
BRIGHTNESS	62%
DMX DELAY	UNL
SHUTTER CLOSE	DISABLE

Restoring the default parameters

PREVIOUS=SET	<p>This feature allows to reset the values of the parameters which were set immediately before FACTORY=SET procedure. In other words, if the default parameters have been set by mistake, this allows to return to the values previously set.</p> <ol style="list-style-type: none"> 1. Connect Synthesis to the power supply, wait till it has completed reset operations. 2. Use the UP/DOWN keys to find the "PREVIOUS" menu. 3. Press ENTER for some seconds to confirm. The message on the display will start to flash. 4. Use the UP/DOWN keys to select the voice "PREVIOUS=SET". 5. Press "Enter" to restore the values cancelling the operation FACTORY DEFAULT. In the meantime the voice PREV stops flashing and the message PREVIOUS=OFF appears.
PREVIOUS=OFF	

Setting the starting position of the rotating gobos, the gobo, colour and effect wheel

SETTING	<p>From the Setting menu, it's possible to set the starting position of the color, gobo and effect wheels, as well as the starting position of the rotating gobos. To carry out the setting, proceed as follows:</p> <ol style="list-style-type: none"> 1. Connect Synthesis to the power supply, wait till it has completed reset operations. 2. Use the UP/DOWN keys to find the "SETTING" menu. 3. Insert the access code to the SETTING submenu. 4. Use the UP/DOWN keys to select the option desired (COLR, GOB1, GOB2, RGB1, RGB1). 5. Press the "Enter" to confirm. The message on the display will start to flash. 6. Set the offset by UP/DOWN keys. 7. Press ENTER to confirm the voice (the display stops flashing) and go back to SETTING submenu. 8. To get out from setting menu press the enter key for 4 seconds.
COLR=0	
GOB1=0	
GOB2=0	
RGB1=0	
RGB2=0	

Test functions

TEST	<p>Test programs can be used in the event of it being necessary to check the correct operation of the fixture or some of its parts. To select the required test program, proceed as follows:</p> <ol style="list-style-type: none"> 1. Connect Synthesis to the power supply, wait till it has completed reset operations. 2. Use the UP/DOWN keys to find the "TEST" menu. 3. Press ENTER for some seconds to confirm. The message on the display will start to flash. 4. Use UP/DOWN keys to select the program corresponding to the part of the fixture to be tested. 5. Press "Enter" to run the test program. 6. Press Enter to quit the test functions, press Enter again a for few seconds until "Test" re-appears on the display.
TEST=RESET	

Reserved functions

RESERVED

Some fixture functions cannot be accessed by operators as they regard software sections as yet to be defined in this firmware release. When RESERVED appears on the display, you are in this section. Access is forbidden.

Temperature

TEMPERATURE

This menu allows to display the internal temperature detected in many points of the fixture and measured both in Celsius and Fahrenheit degrees.

Thanks to a sophisticated software, Synthesis is able to activate internal projections with the aim of avoiding overheating. The internal temperature are kept fixed through the fans electronic control and the lamp power.

To check the internal temperature, proceed as follows:

1. Connect Synthesis to the power supply, wait till it has completed reset operations.
2. Use the UP/DOWN keys to find the "TEMPERATURE" menu.
3. Press "Enter" to confirm.
4. Use UP/DOWN keys to select the temperature to be checked.
5. Press "Enter" to get out from the menu.

Version

VERSION

Only for reading, this menu allows to check the information on the microprocessors software versions used on the fixture.

To check the software version, proceed as follows:

1. Connect Synthesis to the power supply, wait till it has completed reset operations.
2. Use the UP/DOWN keys to find "VERSION" menu.
3. Press "Enter" to confirm.
4. Use UP/DOWN keys to visualize the software installed on the microprocessors.
5. Press "Enter" to exit the menu.

3.5 Error Messages

Error Messages	Description
NO SIGNAL	No signal on DMX input.
SIGNAL ERROR	Signal on DMX input disturbed.
PAN COM FAIL	The Processor-in does not receive data by the processor pan board.
TILT COM FAIL	The Processor-in does not receive data by the processor tilt board.
GOBO COM FAIL	The Processor-in does not receive data by the gobo-color processor board.
ZOOM COM FAIL	The Processor-in does not receive data by the zoom-focus processor board.
CMY COM FAIL	The Processor-in does not receive data by the CMY processor board.
HEAD COM FAIL	The Processor-in does not receive data by the head fans processor board.
BASE COM FAIL	The Processor-in does not receive data by the ballast.
POWER COM FAIL	The Processor-in does not receive data by the pfc.
PAN COM ERROR	The Processor-in receives data by the processor pan board but the communication is disturbed (receiving data failure).
TILT COM ERROR	The Processor-in receive data by the processor tilt board but the communication is disturbed (receiving data failure).
GOBO COM ERROR	The Processor-in receive data by the gobo-color processor board but the communication is disturbed (receiving data failure).
ZOOM COM ERROR	The Processor-in receive data by the zoom/focus processor board but the communication is disturbed (receiving data failure).
CMY COM ERROR	The Processor-in receive data by the CMY processor board but the communication is disturbed (receiving data failure).
HEAD COM ERROR	The Processor-in receive data by the head fans processor board but the communication is disturbed (receiving data failure).
BASE COM ERROR (ricezione dei dati)	The Processor-in receive data by the ballast but the communication is disturbed (receiving data failure).
POWER COM ERROR	The Processor-in receive data by the pfc but the communication is disturbed (receiving data failure).
GOBO FAN FAIL	The fans of the gobo-color processor board are not working.
LAMP FAN FAIL	The rear head fans are not working.
LAMP OVERTEMPERATURE	The temperature of the head rear side, where the lamp is located, is too high.
LAMP TEMPERATUR FAIL	The temperature of the head rear side, where the lamp is located, is not correctly detected as the connection with the temperature sensor is failed.
BASE TEMPERATUR FAIL	The temperature of the ballast is not correctly detected as the connection with the temperature sensor is failed.
POWER TEMPERAT FAIL	The temperature of the pfc is not correctly detected as the connection with the temperature sensor is failed.
LOW BATTERY	The processor-in has been powered without power supply but through the battery, and the battery is low charged.
POWER OVERVOLTAGE	The pfc does not power the fixture because it detects a too high tension on the mains.
POWER OVERTEMPERATUR	The pfc does not power the fixture because it detects a too high temperature on the board itself.

4 MAINTENANCE

4.1 Ordinary Maintenance

Synthesis is internally fitted with three independent modules and this grants more speed in case of technical operations or maintenance service. Synthesis head was designed according to a totally new concept: this has enabled all the fixture's optical functions to be divided in three modules.

Each module is independent from the others from the point of view of electronics and mechanics, and can be extracted by removing two quarter-turn screws and 4-pin connector.

- The first module contains: The CMY CTO dimmer
- The second module contains: 2 gobo wheels, 1 color wheel, animation wheel, Iris diaphragm
- The third module contains: focus-zoom, shutter, prisms and additional lenses, frost.

Important:

- If functions are tested without one or more head modules, it is recommended to do it for a short time, as the absence of the modules can cause an insufficient internal ventilation which, combined with the exposition to the ultraviolet rays and the fixture's heat, could damage the mechanical components.
- You should clean the fixture on a regular basis. In accordance with the environment in which it is installed, the unit needs a different maintenance service as dust, dirt, smoke (either cigarettes and fog fluid) can accumulate and cause malfunctioning. A general check should be done at every lamp replacement (750 hours).
- Do not submerge in liquid!



Servicing should only be conducted by qualified technicians and not by the user. If any liquid has been spilled on or into the fixture, contact SGM Technical Support before attempting to service the fixture.

Exterior Surfaces:

To clean the exterior surfaces proceed as follows:

- Wipe with a soft tissue or use a small vacuum to remove any buildup dust and dirt.
- For stubborn substances, use any product of all-purpose Industrial Strength Cleaner/Degreaser

Interior Surfaces:

To clean the interior surfaces proceed as follow:

- To clean dichroic filters, glass texture and optical components such as ZOOM lens and dichroic reflector, use a soft lens-free polyester cloth with ethyl alcohol. Dichro Gobos: Dampen a soft cloth with isopropyl alcohol or acetone. Gently wipe the surface of the glass. Handle the gobo by the edges (same as handling a CD). Do not touch the surface of the pattern because the oils from your hands can degrade the patterns.

Mechanical Parts:

- **ZOOM:**
Use a soft cloth and ACETONE to remove dust and dirt from the 2 shafts used for the zoom lens movement. Lubricate with Teflon spay grease.
- **FOCUS:**
Use a soft cloth and ACETONE to remove dust and dirt from the 2 shafts used for the focus lens movement. Lubricate with Teflon spay grease.
- **PRISM:**
Giottos are using protected oilless ball bearings which don't need any maintenance.
- **BELTS AND O-RING:**
Tension of the belt and their construction conditions should be checked periodically:
 1. **GOBOS and COLOR WHEELS belts:**
They are very strong and they do not require any maintenance.
 2. **PRISM O-rings:**
They could get dry losing elasticity and showing cracks on their exterior surface. To replace in case of faultyness.
 3. **PAN and TILT belts:**
These belts are very strong and they never fail. Therefore, they could get loose and their tension should be checked periodically.

Cooling fans air passage:

The fans shouldn't be obstructed by the dust. Use a vacuum to remove the dirt from the head and base fans.

BUFFER BATTERY REPLACEMENT.

Synthesis battery is located in the base of the fixture, on display side.

When it becomes necessary to replace the buffer battery, by display message "Low Battery", proceed as follows:

1. Open the base cover (display side)
2. Unscrew the nut fixing the metal support where the battery is located
3. Disconnect the cable on the Processor In board
4. Replace the battery
5. Screw the nut on the metal support
6. Re-connect the cable on the Processor In board
7. Re-fit the base cover

LAMP REPLACEMENT

The lamp replacement has to be considered an ordinary maintenance operation.

Synthesis lamp lifespan is about 750 hours, then it is necessary to replace it. In the total life hours calculation consider that each lamp strike reduces of about 15 minutes the average lamp life.

The time of use can be checked in the display menus "Lamp Strike" and "Lamp Hour". By approaching of the life time ending (as per lamp specifications) it is recommended to replace the lamp before getting damages due to the lamp exploding.

5 CONTROL CHANNELS

Synthesis is compatible with all the consoles using the standard USITT DMX512 signal and can operate in 4 different modes : HRV (35 Ch), HRT (34 Ch), LRV (32 Ch), LRT (31 Ch).

HR (HIGH RESOLUTION) modes use three additional DMX channels rather than the LR (LOW RESOLUTION) operating mode; these channels refer to the 16 bit indexing of the GOBO1 and GOBO2 wheels and to the FOCUS 16 bit. The operating modes and therefore the total number of the channels used by Synthesis depend on the settings of the OPERATING and SPEED CONTROL menus.

OPERATING MODE	CHANNELS	MENU DISPLAY SETTING
HRV	35Ch	SPEED CONTROL = VECTOR
		OPERATING = HIGH RES
HRT	34Ch	SPEED CONTROL = TRACKING
		OPERATING = HIGH RES
LRV	32Ch	SPEED CONTROL = VECTOR
		OPERATING = LOW RES
LRT	31Ch	SPEED CONTROL = TRACKING
		OPERATING = LOW RES

- In TRACKING mode the speed is determined by the cross-fade time set on the console.
- In VECTOR mode the speed is set by the Pan7Tilt Speed channel directly, the cross-fade time in the console has to be 0.



HRV	HRT	LRV	LRT	FUNCTION	DESCRIPTION
Ch 1	Ch 1	Ch 1	Ch 1	Pan MSB	8 bit channels Pan movement
Ch 2	Ch 2	Ch 2	Ch 2	Pan LSB	16 bit channel Pan movement
Ch 3	Ch 3	Ch 3	Ch 3	Tilt MSB	8 bit channel Tilt movement
Ch 4	Ch 4	Ch 4	Ch 4	Tilt LSB	16 bit bit channel Tilt movement
Ch 5	Ch 5	Ch 5	Ch 5	Iris	Iris opening control
Ch 6	Ch 6	Ch 6	Ch 6	Color	6 colors on the whole channel + rainbow effect + music synchronism
Ch 7	Ch 7	Ch 7	Ch 7	Gobo1	8 Gobos + gobo rotation + music synchronism
Ch 8	Ch 8	Ch 8	Ch 8	Shutter/Strobe	Shutter e Strobe with music synchronism/ Black-out gobo and color change
Ch 9	Ch 9	Ch 9	Ch 9	Dimmer	Mechanic Dimmer
Ch 10	Ch 10	Ch 10	Ch 10	Gobo1 Rotation (MSB)	Indexable position and rotation in both directions with adjustable speed(high byte)
Ch 11	Ch 11	Ch 11	Ch 11	Prism	Allows the insertion of the rotating prism or neither
Ch 12	Ch 12	Ch 12	Ch 12	Rotation Prisms	Regulation of prism rotation speed in one direction or the other
Ch 13	Ch 13	Ch 13	Ch 13	Electronic Focus (MSB)	Enables images to be focused (high byte)
Ch 14	Ch 14	Ch 14	Ch 14	Zoom	Widening/narrowing of light beam (9°-36°)
Ch 15	Ch 15	Ch 15	Ch 15	Wheel Diffract	Animation Wheel insertion
Ch 16	Ch 16	Ch 16	Ch 16	Frost	Variable frost filter
Ch 17	-	Ch 17	-	Mspeed	Movement speed controlled through slow/fast crossfade
Ch 18	Ch17	Ch 18	Ch 17	Reset/Lamp	Remote control of the lamp switching on and reset of the unit
Ch 19	Ch18	Ch 19	Ch 18	Gobo1shake	Gobo oscillation with variable speed
Ch 20	Ch 19	Ch 20	Ch 19	Mod_col	Indexable position, Internal hard color change, hard change half color, rainbow 8 speeds, color change with music synchronism
Ch 21	Ch 20	Ch 21	Ch 20	Mod_rotg1	Indexable gobo position, gobo rotation, gobo shaker
Ch 22	Ch 21	Ch 22	Ch 21	Macro	Macro functions
Ch 23	Ch 22	-	-	Rotazione Gobo1(LSB)	Indexable position and rotation in both directions with adjustable speed (low byte)
Ch 24	Ch 23	Ch 23	Ch 22	Gobo2	8 Gobos + raimbow +music synchronism
Ch 25	Ch 24	Ch 24	Ch 23	Gobo2 Rotation (MSB)	Indexable position and rotation in both directions with adjustable speed (high byte)
Ch 26	Ch 25	Ch 25	-	Gobo2 Rotation (LSB)	Indexable position and rotation in both directions with adjustable speed (low byte)
Ch 27	Ch 26	Ch 26	Ch 24	Mod_rotg2	Indexable position, gobo rotation, gobo shaker
Ch 28	Ch 27	Ch 27	Ch 25	Gobo2shake	Adjustable speed and gobo oscillation
Ch 29	Ch 28	Ch 28	Ch 26	Diffract Wheel Rotation	Indexable position and rotation in both directions with adjustable speed
Ch 30	Ch 29	Ch 29	Ch 27	Revolution Diffract Wheel	Animation Wheel rotation at different speed
Ch 31	Ch 30	Ch 30	Ch 28	Cyano	Cyan linear insertion from white to full color
Ch 32	Ch 31	Ch 31	Ch 29	Magenta	Magenta linear insertion from white to full color
Ch 33	Ch 32	Ch 32	Ch 30	Yellow	Yellow linear insertion from white to full color
Ch 34	Ch 33	-	Ch 31	CTO	Cto linear insertion from white to full color
Ch 35	Ch 34	-	-	Focus(LSB)	Focus linear insertion (low byte)

Iris (Ch5)

DMX VALUE	FUNCTION
0 .. 255	Linear variation 0 – 100%

Color Mode (Ch20)

DMX VALUE	CENTRAL VALUE	FUNCTION	
0 – 50	25	FULL COLOR	Digital color adjustment on central position
51 – 101	75	HALF COLOR	Digital color adjustment on intermediate position
102 – 152	125	COLOR SOFT	Analogic color selection on every position
153 – 203	175	RAINBOW SOFT	Continuous color rotation with adjustable speed
204 – 255	225	MUSIC HARD CHANGE	Sound to light color change to low frequency

Color (ch6 with color mode (ch20) = Full Color

DMX VALUE	CENTRAL VALUE	FUNCTION
0 – 35	17	WHITE
36 – 71	53	RED
72 – 107	89	GREEN
108 – 145	125	BLUE
146 – 181	161	PINK
182– 215	197	AMBER
216 – 255	233	WOOD

Color (ch6) with color mode (ch20) = Half Color

DMX VALUE	CENTRAL VALUE	FUNCTION
0 - 31	15	WHITE
32 – 63	47	WHITE / RED
64 – 95	79	RED / GREEN
96 – 127	111	VERDE / BLU
128 – 159	143	BLUE / PINK
160 – 191	175	PINK / AMBER
192 – 223	207	AMBER / WOOD
224 – 255	239	WOOD / WHITE

Color (ch6) with color mode (ch20) = Color Soft

DMX512 LEVEL RANGE 0-255	FUNCTION	
Linear Color indexing.	C = 0	WHITE
	C = 36	RED
	C = 72	GREEN
	C = 108	BLUE
	C = 144	PINK
	C = 180	AMBER
	C = 216	WOOD

Color (ch6) with color mode (ch20) = Rainbow Soft

DMX VALUE	CENTRAL VALUE	FUNCTION
0 - 15	8	SPEED 1
16 - 31	24	SPEED 2
32 - 47	40	SPEED 3
48 - 63	56	SPEED 4
64 - 79	72	SPEED 5
80 - 95	88	SPEED 6
96 - 111	104	SPEED 7
112 - 127	120	SPEED 8
128 - 143	136	SPEED 9
144 - 159	152	SPEED 10
160 - 175	168	SPEED 11
176 - 191	184	SPEED 12
192 - 207	200	SPEED 13
208 - 223	216	SPEED 14
224 - 239	232	SPEED 15
240 - 255	248	SPEED 16

Color (ch6) with color mode (ch20) = Music Hard Change

DMX VALUE	FUNCTION
0 - 127	Sound to light full color change
128 - 255	Sound to light split color change

Gobo Wheel 1 (Ch7)

DMX VALUE	CENTRAL VALUE	FUNCTION
0 - 20	10	NO GOBO
21 - 41	31	GOBO1
42 - 62	52	GOBO2
63 - 83	73	GOBO3
84 - 104	94	GOBO4
105 - 125	115	GOBO5
126 - 146	136	GOBO6
147 - 167	157	GOBO7
168 - 189	178	GOBO8
190 - 196	193	RAINBOW SPEED1
197 - 203	200	RAINBOW SPEED 2
204 - 210	207	RAINBOW SPEED 3
211 - 217	214	RAINBOW SPEED 4
218 - 224	221	RAINBOW SPEED 5
225 - 231	228	RAINBOW SPEED 6
232 - 238	235	RAINBOW SPEED 7
239 - 245	242	RAINBOW SPEED 8
246 - 255	252	SOUND TO LIGHT GOBO CHANGE

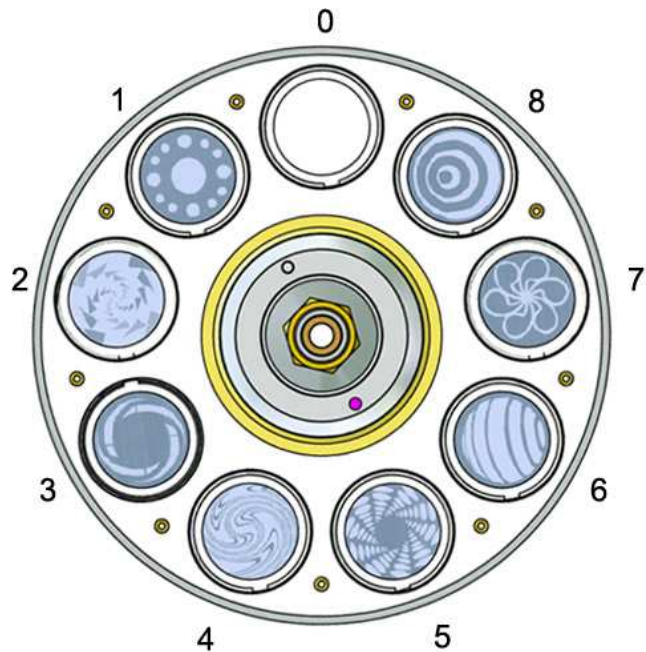

Shutter / Strobe (Ch8)

DMX VALUE	CENTRAL VALUE	FUNCTION
0 - 7	4	Closed
8 -15	12	Strobe at the frequency of 1 Hz
16 - 23	20	Strobe at the frequency of 1,38 Hz
24 – 31	28	Strobe at the frequency of 1,6 Hz
32 – 39	36	Strobe at the frequency of 1,9 Hz
40 - 47	44	Strobe at the frequency of 2,3 Hz
48 - 55	52	Strobe at the frequency of 2,7 Hz
56 - 63	60	Strobe at the frequency of 3,4 Hz
64 - 71	68	Strobe at the frequency of 4 Hz
72 -79	76	Strobe at the frequency of 5 Hz
80 -87	84	Strobe at the frequency of 6 Hz
88 - 95	92	Strobe at the frequency of 7 Hz
96 - 103	100	Strobe at the frequency of 8 Hz
104 - 111	108	Strobe at the frequency of 9 Hz
112 - 119	116	Strobe at the frequency of 10 Hz
120 - 136	128	Sound to light strobe effect at max Frequency synchronized on the bass
137 - 153	145	Sound to light strobe synchronized on the bass
154 – 170	162	Autoshade opened on the gobos
171 - 187	179	Autoshade opened on the colors
188 - 204	196	Autoshade opened on the gobos and the colors
205 - 221	213	Opened with slow gobo change
222 - 255		Opened

Dimmer (Ch9)

DMX512 LEVEL RANGE 0-255	FUNCTION
0 - 255	Linear adjustment 0 – 100%

Prism/ Beam expander (Ch11)

DMX512 LEVEL RANGE 0-255	FUNCTION
0 - 85	No prism – No Expander
86 - 170	Beam expander inserted
171 - 255	Prism inserted

Prism Rotation (Ch12)

DMX VALUE	FUNCTION
0 . . 111	Down rotation [max..min]
112 - 143	Stopped
144 . . 255	Up rotation [min..max]

Electronic Focus (Ch13)

DMX VALUE	FUNCTION
0 - 255	Linear adjustment 0 – 100%

Zoom (Ch14)

DMX VALUE	FUNCTION
255	Zoom in (angle 9°)
0 - 255	Linear variation
0	Zoom out (angle 36°)

Animation wheel Mode (Ch15)

DMX512 LEVEL RANGE 0-255	FUNCTION
0 - 79	Not inserted
80 - 159	Animation wheel inserted, adjustable speed in both direction
160 - 255	Animation wheel inserted, indexable position

Animation wheel (ch29) with Animation wheel mode (ch15)= Animation wheel rotation at different speed in both directions.

DMX512 LEVEL RANGE 0-255	FUNCTION
0 . . 111	Down rotation [max..min]
112 - 143	Stopped Animation wheel
144 . . 255	Up rotation [min..max]

Animation wheel (ch29) with Animation wheel mode (ch15)= Animation wheel inserted, indexable position.

DMX512 LEVEL RANGE 0-255	FUNCTION
0 . . 255	Animation wheel position adjustment in linear mode on all the 360°

Frost (Ch16)

DMX VALUE	FUNCTION
0	Frost disabled
0 - 255	Linear variation
255	Frost all inserted

Mspeed (Ch17)

DMX VALUE	FUNCTION
0 . . 3	Controller cross fade
4 . . 255	Slowest. . Fastest

Remote lamp striking and reset (Ch18)

DMX512	FUNCTION	
10 – 60	OFF	LAMP
61 – 129	HYSTERESIS	
130 - 179	ON	
180 – 239	HYSTERESIS	RESET
240 – 255	RESET	

Gobo1 shake (Ch19)

DMX VALUE	CENTRAL VALUE	FUNCTION
0 – 47		Goboshake disabled
48 – 60	54	Goboshake speed 1
61 – 73	67	Goboshake speed 2
74 – 86	80	Goboshake speed 3
87 – 99	93	Goboshake speed 4
100 – 112	106	Goboshake speed 5
113 – 125	119	Goboshake speed 6
126 – 138	132	Goboshake speed 7
139 – 151	145	Goboshake speed 8
152 – 164	158	Goboshake speed 9
165 – 177	171	Goboshake speed 10
178 – 190	184	Goboshake speed 11
191 – 203	197	Goboshake speed 12
204 – 216	210	Goboshake speed 13
217 – 229	223	Goboshake speed 14
230 – 242	236	Goboshake speed 15
243 – 255	249	Goboshake speed 16

Macro (Ch22)

VALORE DMX	VALORE CENTRALE	FUNZIONE
0 - 7	4	No Macro
8 - 15	12	Macro1
16 - 23	20	Macro2
24 - 31	28	Macro3
32 - 39	36	Macro4
40 - 47	44	Macro5
48 - 55	52	Macro6
56 - 63	60	Macro7
64 - 71	68	Macro8
72 - 79	76	Macro9
80 - 87	84	Macro10
88 - 95	92	Macro11
96 - 103	100	Macro12
104 - 111	108	Macro13
112 - 119	116	Macro14
120 - 127	124	Macro15
128 - 135	132	Macro16
136 - 143	140	Reserved for future use
144 - 151	148	Reserved for future use
152 - 159	156	Reserved for future use
160 - 167	164	Reserved for future use
168 - 175	172	Reserved for future use
176 - 183	180	Reserved for future use
184 - 191	188	Reserved for future use
192 - 199	196	Reserved for future use
200 - 207	204	Reserved for future use
208 - 215	212	Reserved for future use
216 - 223	220	Reserved for future use
224 - 231	228	Reserved for future use
232 - 239	236	Reserved for future use
240 - 247	244	Reserved for future use
248 - 255	252	Reserved for future use

Gobo Wheel 2 (Ch24)

DMX VALUE	CENTRAL VALUE	FUNCTION
0 - 20	10	NO GOBO
21 - 41	31	GOBO 1
42 - 62	52	GOBO 2
63 - 83	73	GOBO 3
84 - 104	94	GOBO 4
105 - 125	115	GOBO 5
126 - 146	136	GOBO 6
147 - 167	157	GOBO 7
168 - 189	178	GOBO 8
190 - 196	193	RAINBOW SPEED 1
197 - 203	200	RAINBOW SPEED 2
204 - 210	207	RAINBOW SPEED 3
211 - 217	214	RAINBOW SPEED 4
218 - 224	221	RAINBOW SPEED 5
225 - 231	228	RAINBOW SPEED 6
232 - 238	235	RAINBOW SPEED 7
239 - 245	242	RAINBOW SPEED 8
246 - 255	252	SOUND TO LIGHT GOBO CHANGE

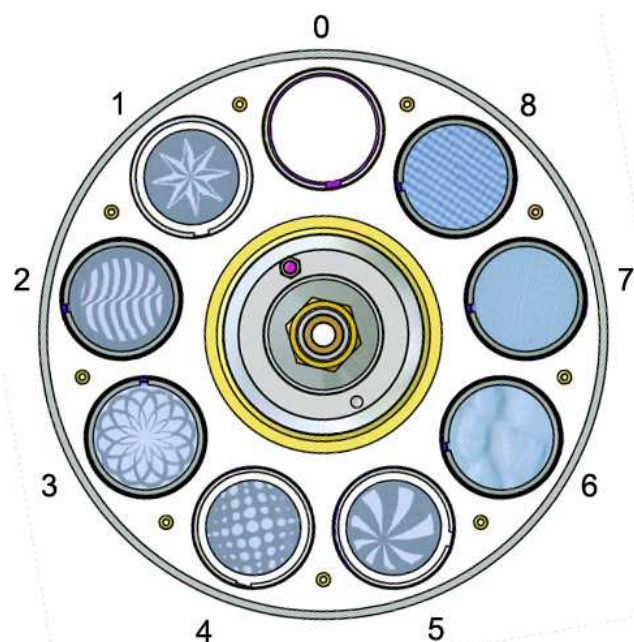

Gobo rotation mode channel (Ch21)

DMX512 LEVEL RANGE 0-255	FUNCTION
0 .. 127	Gobos Wheel 1 position indexing
128 .. 255	Gobos1 wheel rotation at adjustable speed in both directions

Gobo1 rotation (ch10) with gobo1 rotation mode (ch21)= gobo1 indexable position

DMX512 LEVEL RANGE 0-255	FUNCTION
0 .. 255	Gobo1 position adjustment in linear mode on all 360° (MSB)

Gobo1 rotatotion (ch23) with gobo1 rotation mode (ch21)= gobo1 indexable position

DMX512 LEVEL RANGE 0-255	FUNCTION
0 .. 255	Gobo1 position adjustment in linear mode on all 360° (LSB)

Gobo 1 rotation (ch10) gobo1 rotation mode (ch21)= gobo1 rotation at different speed in both directions.

DMX512 LEVEL RANGE 0-255	FUNCTION
0 .. 111	Down rotation [max . . .min]
112 – 144	Stopped
145 .. 255	Up rotation [min ... max]

Macro(Ch22)

DMX VALUE	CENTRAL VALUE	DESCRIPTION	CHANNELS USED
0 - 7	4		
8 - 15	12	Slow dimmer opening ramp and fast closing.	DimmerShutter
16 - 23	20	Slow dimmer closing ramp and fast opening.	Dimmer Shutter
24 - 31	28	Odd-numbered fixtures run a slow dimmer opening ramp. Even-numbered fixtures run a slow dimmer closing ramp.	Dimmer Shutter
32 - 39	36	Odd-numbered fixtures run a slow dimmer opening ramp and even-numbered fixtures' shutters are closed. Then even-numbered fixtures run a slow dimmer opening ramp and odd-numbered fixtures' shutters are closed.	Dimmer Shutter
40 - 47	44	Odd-numbered fixtures run a slow dimmer closing ramp while even-numbered fixtures' shutters are open. Then even-numbered fixtures run a slow dimmer closing ramp and even-numbered fixtures' shutters are open.	Dimmer Shutter
48 - 55	52	Slow iris opening ramp and fast closing.	Iris
56 - 63	60	Slow iris closing ramp and fast opening.	Iris
64 - 71	68	Fast iris closing and opening.	iris
72 - 79	76	Odd-numbered fixtures run a slow iris opening ramp, even-numbered fixtures run a slow iris closing ramp.	iris
80 - 87	84	Odd-numbered fixtures run a slow iris opening ramp whereas even-numbered fixtures' irises are closed. Then even-numbered fixtures run a slow iris opening ramp and even-numbered fixtures' irises are closed.	Iris
88 - 95	92	Odd-numbered fixtures run a slow iris closing ramp whereas even-numbered fixtures' irises are open. Then even-numbered fixtures run a slow iris closing ramp and odd-numbered fixtures' irises are open.	Iris
96 - 103	100	Even-numbered fixtures close their irises, whereas odd-numbered fixtures open them and vice versa.	Iris
104 - 111	108	Random strofe.	Shutter
112 - 119	116	Slow Frost insertion ramp followed by slow removal ramp.	Frost
120 - 127	124	Slow Frost insertion ramp followed by fast removal ramp.	Frost
128 - 135	132	Slow Frost insertion ramp on even-numbered fixtures, whereas Frost is disabled on odd-numbered units. Then slow Frost insertion ramp on odd-numbered fixtures and Frost disabled on even-numbered fixtures.	Frost
136 - 143	140	Reserved for future use	
144 - 151	148	Reserved for future use	
152 - 159	156	Reserved for future use	
160 - 167	164	Reserved for future use	
168 - 175	172	Reserved for future use	
176 - 183	180	Reserved for future use	
184 - 191	188	Reserved for future use	
192 - 199	196	Reserved for future use	
200 - 207	204	Reserved for future use	
208 - 215	212	Reserved for future use	
216 - 223	220	Reserved for future use	
224 - 231	228	Reserved for future use	
232 - 239	236	Reserved for future use	
240 - 247	244	Reserved for future use	
248 - 255	252	Reserved for future use	

Gobos2 channel mode (Ch27)

DMX512 LEVEL RANGE 0-255	FUNCTION
0 . . 127	Gobos 2 wheel position indexing
128 . . 255	Gobos2 at adjustable speed in both directions

GOBOS ROTATION CHANNEL (Ch25) Gobo2 rotation mode (Ch27)= gobos2 position indexing

DMX512 LEVEL RANGE 0-255	FUNCTION
0 . . 255	Gobo2 position adjustment in linear mode on all 360° (MSB)

GOBOS ROTATION CHANNEL (Ch25) with Gobo2 rotation mode (Ch27) = gobos2 position indexing

DMX512 LEVEL RANGE 0-255	FUNCTION
0 . . 255	Gobo2 position adjustment in linear mode on all 360° (LSB)

GOBOS ROTATION CHANNEL (Ch25) with Gobo2 rotation mode (Ch27) = gobos2 rotation at adjustable speed in both directions

DMX512 LEVEL RANGE 0-255	FUNCTION
0 . . 111	Down [max . . . min]
112 – 144	Stopped
145 . . 255	Up rotation [min . . . max]

Gobo2 shake (Ch28)

DMX VALUE	CENTRAL VALUE	FUNCTION
0 – 47		No function applied
48 – 60	54	Goboshake speed 1
61 – 73	67	Goboshake speed 2
74 – 86	80	Goboshake speed 3
87 – 99	93	Goboshake speed 4
100 – 112	106	Goboshake speed 5
113 – 125	119	Goboshake speed 6
126 – 138	132	Goboshake speed 7
139 – 151	145	Goboshake speed 8
152 – 164	158	Goboshake speed 9
165 – 177	171	Goboshake speed 10
178 – 190	184	Goboshake speed 11
191 – 203	197	Goboshake speed 12
204 – 216	210	Goboshake speed 13
217 – 229	223	Goboshake speed 14
230 – 242	236	Goboshake speed 15
243 – 255	249	Goboshake speed 16

Animation wheel Revolution (Ch30)

DMX512 LEVEL RANGE 0-255	FUNCTION
0 .. 255	Linear variation [0...360°]

Cyan (Ch31)

DMX VALUE	FUNCTION
0	White Open
0 - 255	Linear variation [0...100%]
255	Full color

Magenta (Ch32)

DMX VALUE	FUNCTION
0	White Open
0 - 255	Linear variation [0...100%]
255	Full color

Yellow (Ch33)

DMX VALUE	FUNCTION
0	White Open
0 - 255	Linear variation [0...100%]
255	Full color

CTO (Ch34)

DMX VALUE	FUNCTION
0	White Open
0 - 255	Linear variation [0...100%]
255	Full Color

Conversion Table

DMX VALUE	MSPEED (in seconds)	DMX VALUE	MSPEED (in seconds)	DMX VALUE	MSPEED (in seconds)	DMX VALUE	MSPEED (in seconds)
0 -- 1	cross fade	65	150	129	72	193	17
2	cross fade	66	149	130	70	194	17
3	cross fade	67	147	131	69	195	16
4	243	68	146	132	68	196	16
5	241	69	145	133	67	197	15
6	240	70	143	134	66	198	15
7	238	71	142	135	65	199	14
8	236	72	141	136	64	200	14
9	234	73	139	137	63	201	13
10	233	74	138	138	62	202	13
11	231	75	137	139	61	203	12
12	229	76	135	140	60	204	12
13	227	77	134	141	59	205	12
14	226	78	133	142	58	206	11
15	224	79	131	143	57	207	11
16	222	80	130	144	56	208	10
17	221	81	129	145	55	209	10
18	219	82	128	146	54	210	10
19	217	83	126	147	53	211	9
20	216	84	125	148	52	212	9
21	214	85	124	149	51	213	9
22	213	86	122	150	50	214	8
23	211	87	121	151	49	215	8
24	209	88	120	152	48	216	8
25	208	89	119	153	47	217	7
26	206	90	117	154	46	218	7
27	205	91	116	155	45	219	7
28	203	92	115	156	45	220	6
29	202	93	114	157	44	221	6
30	200	94	112	158	43	222	6
31	199	95	111	159	42	223	6
32	197	96	110	160	41	224	5
33	195	97	109	161	40	225	5
34	194	98	108	162	39	226	5
35	192	99	106	163	38	227	5
36	191	100	105	164	38	228	4
37	189	101	104	165	37	229	4
38	188	102	103	166	36	230	4
39	187	103	101	167	35	231	4
40	185	104	100	168	34	232	4
41	184	105	99	169	34	233	3
42	182	106	98	170	33	234	3
43	181	107	97	171	32	235	3
44	179	108	95	172	31	236	3
45	178	109	94	173	30	237	3
46	176	110	93	174	30	238	3
47	175	111	92	175	29	239	3
48	173	112	91	176	28	240	2
49	172	113	90	177	28	241	2
50	171	114	88	178	27	242	2
51	169	115	87	179	26	243	2
52	168	116	86	180	25	244	2
53	166	117	85	181	25	245	2
54	165	118	84	182	24	246	2
55	164	119	83	183	23	247	2
56	162	120	82	184	23	248	2
57	161	121	80	185	22	249	2
58	159	122	79	186	22	250	2
59	158	123	78	187	21	251	2
60	157	124	77	188	20	252	2
61	155	125	76	189	20	253	2
62	154	126	75	190	19	254	2
63	153	127	74	191	19	255	2
64	151	128	73	192	18		



USER'S MANUAL REL. 1.00

SGM TECHNOLOGY FOR LIGHTING SPA
VIA PIO LA TORRE, 1 - 61010 TAVULLIA (PU), ITALY
TEL. +39 0721 476477 - FAX +39 0721 476170
www.sgm.it - info@sgm.it