

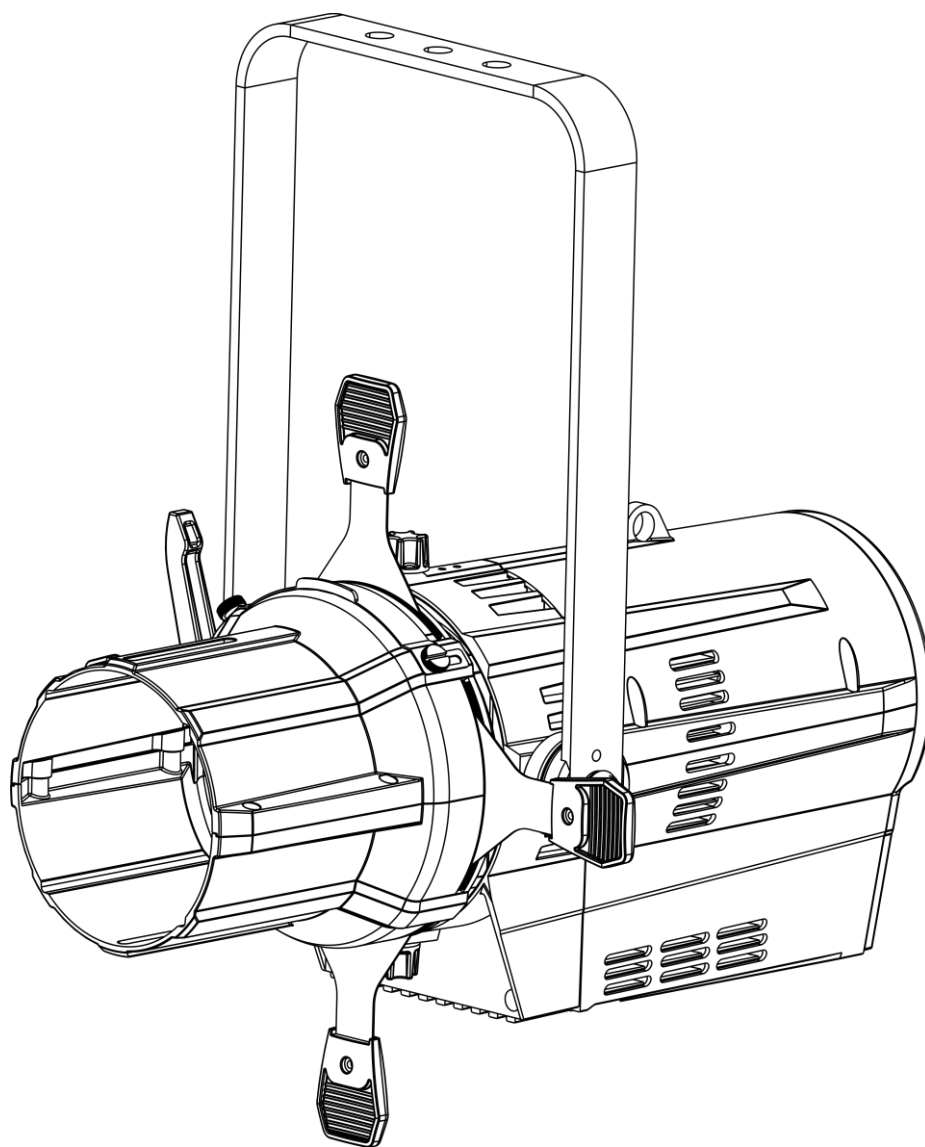

**MANUAL**



**ENGLISH**

**Performer Profile 600 MKII DDT V1**

**Ordercode: 33063**

**Table of contents**

**Warning** .....3  
Safety Instructions .....3  
Operating Determinations .....5  
Rigging .....5  
Connection with the mains .....6  
Return Procedure .....7  
Claims .....7

**Description of the device** .....8  
Overview .....8  
Backside .....10

**Installation** .....10

**Set Up and Operation** .....10  
Input Voltage Switch .....11  
Lens Location .....11  
Focusing the Beam .....11  
Color Frame Retaining Clip .....12  
Color Notes .....12  
Shaping the Beam .....12  
Shutters .....13  
Drop-in Iris Slot .....13  
Rotating the Barrel Assembly .....14  
Setting the Angle .....14  
Control Modes .....15  
    One Performer (Stand-alone) .....15  
    Multiple Performers (Master/Slave control) .....15  
    Multiple Performers (DMX Control) .....16  
Fixture Linking .....17  
Data Cabling .....17  
Control Panel .....18  
Control Mode .....18  
DMX Addressing .....18  
Menu Overview .....19  
Main Menu Options .....20  
    1. Dimmer .....20  
    2. Run Mode .....21  
    3. Address .....21  
    4. Setting .....21  
        4.1. Safety Key .....22  
        4.2. Dimmer Speed .....22  
        4.3. Dimming Curve Settings .....22  
        4.4. Performance Settings .....22  
        4.5. Settings Menu Safety Lock .....22  
        4.6. DMX Channel Modes .....23  
        4.7. Save DMX/Blackout .....23  
        4.8. Reset Settings .....23  
        4.9. Mode Setting .....23  
        4.10. Refresh Rate .....23  
DMX Channels .....24  
    1 Channel (UNO) .....24  
    2 Channels (DOS) .....24  
    3 Channels (STD.P) .....24

**Cleaning** .....25  
    Cleaning 19°, 26°, 36° and 50° glass lenses .....25  
    Cleaning the Reflector .....25

**Maintenance** .....26  
    Replacing the Fuse .....26

**Troubleshooting** .....26  
    No Light .....26  
    No Response to DMX.....27

**Product Specifications** .....28

**Dimensions** .....29

## Warning



**For your own safety, please read this user manual carefully  
before your initial start-up!**



### Unpacking Instructions

Immediately upon receiving this product, carefully unpack the carton and check the contents to ensure that all parts are present, and have been received in good condition. Notify the dealer immediately and retain packing material for inspection if any parts appear damaged from shipping or the carton itself shows signs of mishandling. Save the carton and all packing materials. In the event that a fixture must be returned to the factory, it is important that the fixture be returned in the original factory box and packing.

### Your shipment includes:

- Showtec Performer Profile 600 MKII DDT
- Safety cable
- User manual

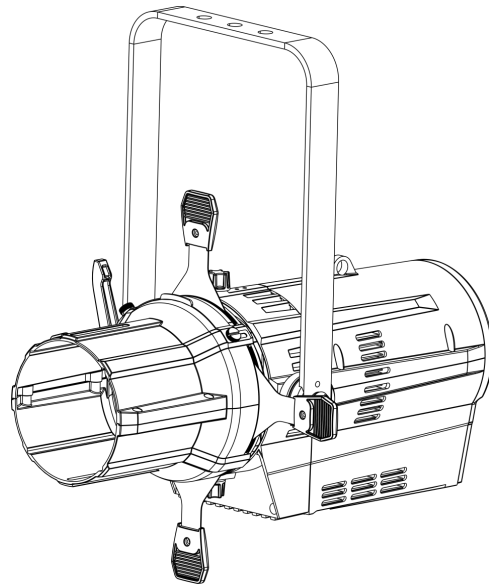

### LED Expected Lifespan

LEDs gradually decline in brightness over time. HEAT is the dominant factor that leads to the acceleration of this decline. Packaged in clusters, LEDs exhibit higher operating temperatures than in ideal or singular optimum conditions. For this reason, when all color LEDs are used at their fullest intensity, life of the LEDs is significantly reduced. If improving the lifespan is of higher priority, place care in providing for lower operational temperatures. This may include climatic-environmental and the reduction of overall projection intensity.



### CAUTION!

**Keep this device away from rain and moisture!  
Unplug mains lead before opening the housing!**



### Safety Instructions

Every person involved with the installation, operation and maintenance of this device has to:

- be qualified
- follow the instructions of this manual



**CAUTION! Be careful with your operations.  
With a dangerous voltage you can suffer  
a dangerous electric shock when touching the wires!**



Before the initial start-up, please make sure that there is no damage caused by transportation. Should there be any, consult your dealer and do not use the device.

To maintain perfect condition and to ensure a safe operation, it is absolutely necessary for the user to follow the safety instructions and warning notes contained in this manual.

Please consider that damages caused by manual modifications to the device are not subject to warranty.

This device contains no user-serviceable parts. Refer servicing to qualified technicians only.

### **IMPORTANT:**

The manufacturer will not accept liability for any resulting damages caused by the non-observance of this manual or any unauthorized modification to the device.

- Never let the power cord come into contact with other cables! Handle the power cord and all connections with the mains with particular caution!
- Never remove warning or informative labels from the unit.
- Never use anything to cover the ground contact.
- Never lift the fixture holding it by the projector-head, as the mechanics may be damaged. Always hold the fixture by the transport handles.
- Never place any material over the lens.
- Never look directly into the light source.
- Never leave any cables lying around.
- Do not insert objects into air vents.
- Do not connect this device to a dimmer pack.
- Do not switch the device on and off in short intervals, as this will reduce the device's life.
- Do not touch the device's housing bare-handed during its operation (housing becomes very hot). Allow the fixture to cool for at least 5 minutes before handling.
- Do not shake the device. Avoid brute force when installing or operating the device.
- Only use the device indoors, avoid contact with water or other liquids.
- Only operate the fixture after having checked if the housing is firmly closed and all screws are tightly fastened.
- Only operate the device after having familiarized with its functions.
- Avoid flames and do not put close to flammable liquids or gases.
- Always keep the case closed while operating.
- Always allow a free air space of at least 50 cm around the unit for ventilation.
- Always disconnect power from the mains, when device is not used or before cleaning! Only handle the power cord holding it by the plug. Never pull out the plug by tugging the power cord.
- Make sure that the device is not exposed to extreme heat, moisture or dust.
- Make sure that the available voltage is not higher than stated on the rear panel.
- Make sure that the power cord is never crimped or damaged. Check the device and the power cord from time to time.
- If the lens is obviously damaged, it has to be replaced.
- If device was dropped or struck, disconnect mains power supply immediately. Have a qualified engineer inspect for safety before operating.
- If the device has been exposed to drastic temperature fluctuation (e.g. after transportation), do not switch it on immediately. The arising condensation water might damage your device. Leave the device switched off until it has reached room temperature.
- If your Showtec device fails to work properly, discontinue the use immediately. Pack the unit securely (preferably in the original packing material), and return it to your Showtec dealer for service.
- For adult use only. The effect must be installed beyond the reach of children. Never leave the unit running unattended.
- Never attempt to bypass the thermostatic switch or fuses.
- For replacement use fuses of same type and rating only.

- The user is responsible for correct positioning and operating of the Performer. The manufacturer will not accept liability for damages caused by the misuse or incorrect installation of this device.
- This device falls under protection class I. Therefore it is essential to connect the yellow/green conductor to earth.
- Repairs, servicing and electric connection must be carried out by a qualified technician.
- WARRANTY: Till one year after date of purchase.

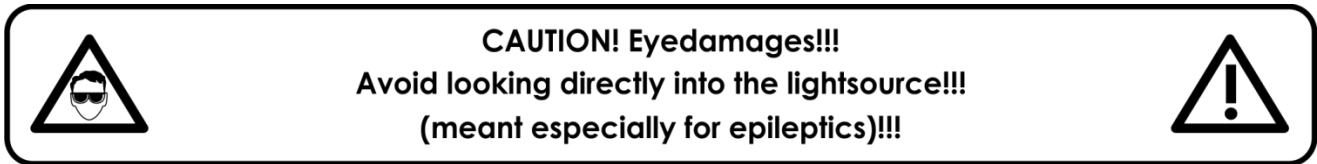

### Operating Determinations

- This device is not designed for permanent operation. Consistent operation breaks will ensure that the device will serve you for a long time without defects.
- The minimum distance between light output and the illuminated surface must be bigger than 1 meter.
- The maximum ambient temperature  $t_a = 40^\circ\text{C}$  must never be exceeded.
- The relative humidity must not exceed 50 % with an ambient temperature of  $40^\circ\text{C}$ .
- If this device is operated in any other way than the one described in this manual, the product may suffer damages and the warranty becomes void.
- Any other operation may lead to dangers like short-circuit, burns, electric shock, crash, etc.

*You endanger your own safety and the safety of others!*

### Rigging

*Please follow the European and national guidelines concerning rigging, trussing and all other safety issues.*

*Do not attempt the installation yourself !*

*Always let the installation be carried out by an authorized dealer !*

### Procedure:

- If the Performer is lowered from the ceiling or high joists, professional trussing systems have to be used.
- Use a clamp to mount the Performer, with the mounting bracket, to the trussing system.
- The Performer must never be fixed swinging freely in the room.
- The installation must always be secured with a safety attachment, e.g. an appropriate safety net or safety cable.
- When rigging, derigging or servicing the Performer, always make sure, that the area below the installation site is secured and that there are not any unauthorized people around.

*Improper installation can cause serious injuries and/or damage of property!*

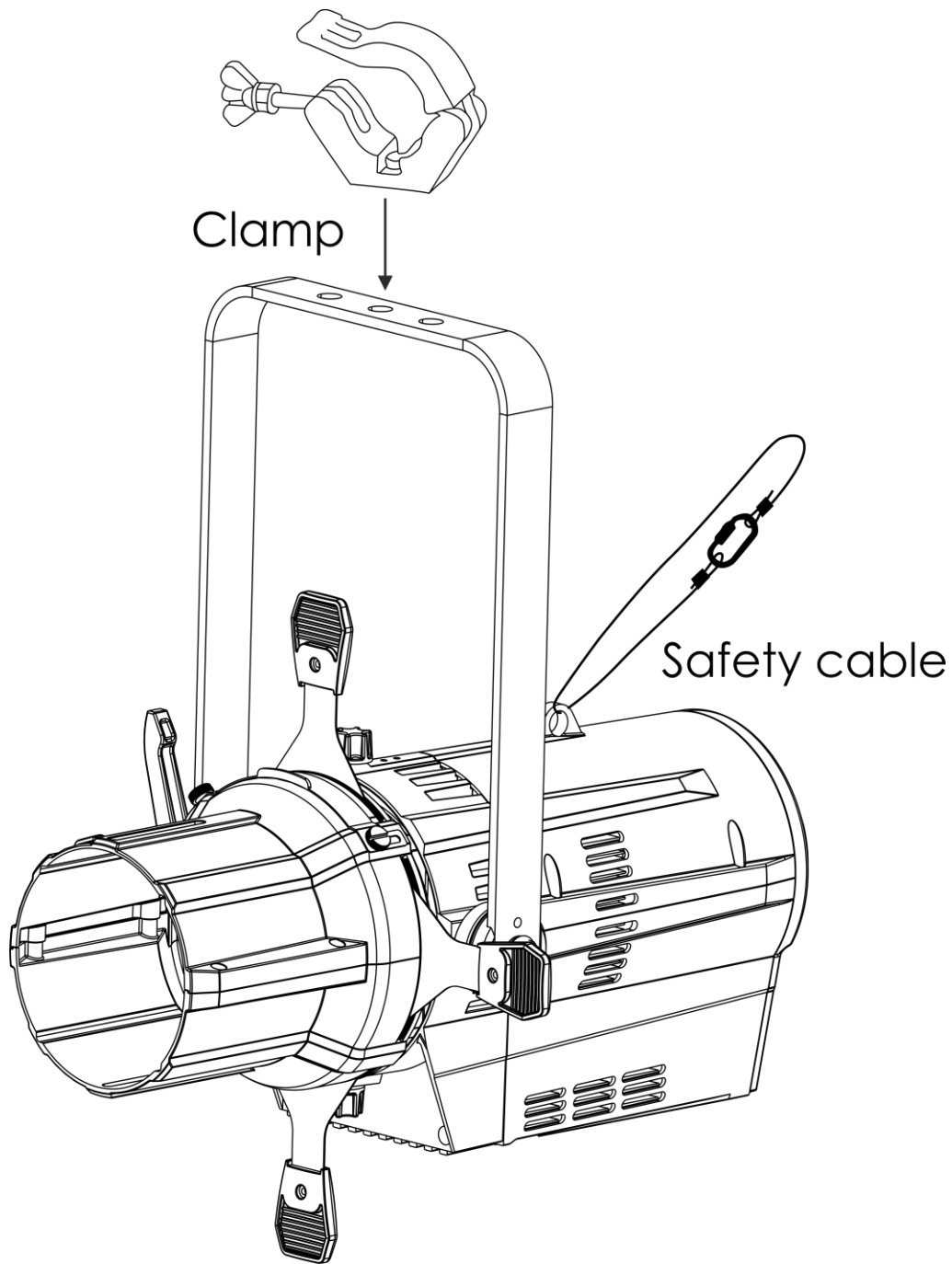

### Connection with the mains

Connect the device to the mains with the power-plug.  
Always check if the right color cable is connected to the right place.

International	EU Cable	UK Cable	US Cable	Pin
L	BROWN	RED	YELLOW/COPPER	PHASE
N	BLUE	BLACK	SILVER	NEUTRAL
⊕	YELLOW/GREEN	GREEN	GREEN	PROTECTIVE GROUND

*Make sure that the device is always properly connected to the earth!*

*Improper installation can cause serious injuries and/or damage of property!*



### **Return Procedure**

Returned merchandise must be sent prepaid and in the original packing, call tags will not be issued. Package must be clearly labeled with a Return Authorization Number (RMA number). Products returned without an RMA number will be refused. Highlite will not accept the returned goods or any responsibility. Call Highlite 0031-455667723 or mail [aftersales@highlite.nl](mailto:aftersales@highlite.nl) and request an RMA prior to shipping the fixture. Be prepared to provide the model number, serial number and a brief description of the cause for the return. Be sure to properly pack fixture, any shipping damage resulting from inadequate packaging is the customer's responsibility. Highlite reserves the right to use its own discretion to repair or replace product(s). As a suggestion, proper UPS packing or double-boxing is always a safe method to use.

**Note: If you are given an RMA number, please include the following information on a piece of paper inside the box:**

- 01) Your name
- 02) Your address
- 03) Your phone number
- 04) A brief description of the symptoms

### **Claims**

The client has the obligation to check the delivered goods immediately upon delivery for any shortcomings and/or visible defects, or perform this check after our announcement that the goods are at their disposal. Damage incurred in shipping is the responsibility of the shipper; therefore the damage must be reported to the carrier upon receipt of merchandise.

It is the customer's responsibility to report and submit claims with the shipper in the event that a fixture is damaged due to shipping. Transportation damage has to be reported to us within one day after receipt of the delivery.

Any return shipment has to be made post-paid at all times. Return shipments must be accompanied with a letter defining the reason for return shipment. Non-prepaid return shipments will be refused, unless agreed otherwise in writing.

Complaints against us must be prepared in writing or sent by fax within 10 working days after receipt of the invoice. After this period complaints will not be handled anymore.

Complaints will only then be considered if the client has so far complied with all parts of the agreement, regardless of the agreement from which the obligation is resulting.



## Description of the device

### Features

The Showtec Performer Profile 600 MKII DDT is a theater spotlight fixture with high output and great effects.

- Input voltage: 100-240V AC, 50/60Hz
- Power consumption: 250W
- Light source: 19 x 10W LED
- Light output: 6522 Lumen
- Peak intensity: 71900 cd
- Color rendering: >90Ra
- Color temperature: 3200K
- Dimmer: 0-100%
- Strobe: 0-20Hz
- Dimming curves: Dimm4 technology, 4 presets
- Dimming resolution: 16-bit
- Connections: 3-pin/5-pin DMX signal connectors IN/OUT, Pro power connectors IN/OUT
- Refresh rate: 1200Hz
- DMX channels: 1, 2 or 3 channels
- Control: Stand-alone, Master/Slave, DMX
- Extremely quiet
- Housing: Die-cast aluminum
- Cooling: Internal fan
- Accessory slot for motorized pattern devices or optional iris
- IP rating: IP-20
- Fuse: T6,3AL/250V
- Dimensions: 480 x 290 x 462 mm (LxWxH)
- Weight: 8,2 kg

### Optional accessories

[33070](#) - Zoom Lens Performer Profile, 15° - 30°

[33071](#) - Zoom Lens Performer Profile, 25° - 50°

[33072](#) - 19° lens Performer Profile

[33073](#) - 36° lens Performer Profile

[33074](#) - 50° lens Performer Profile

### Overview

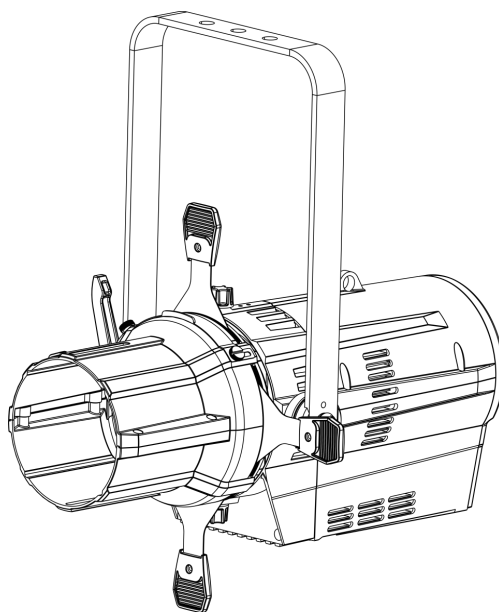

Fig. 01

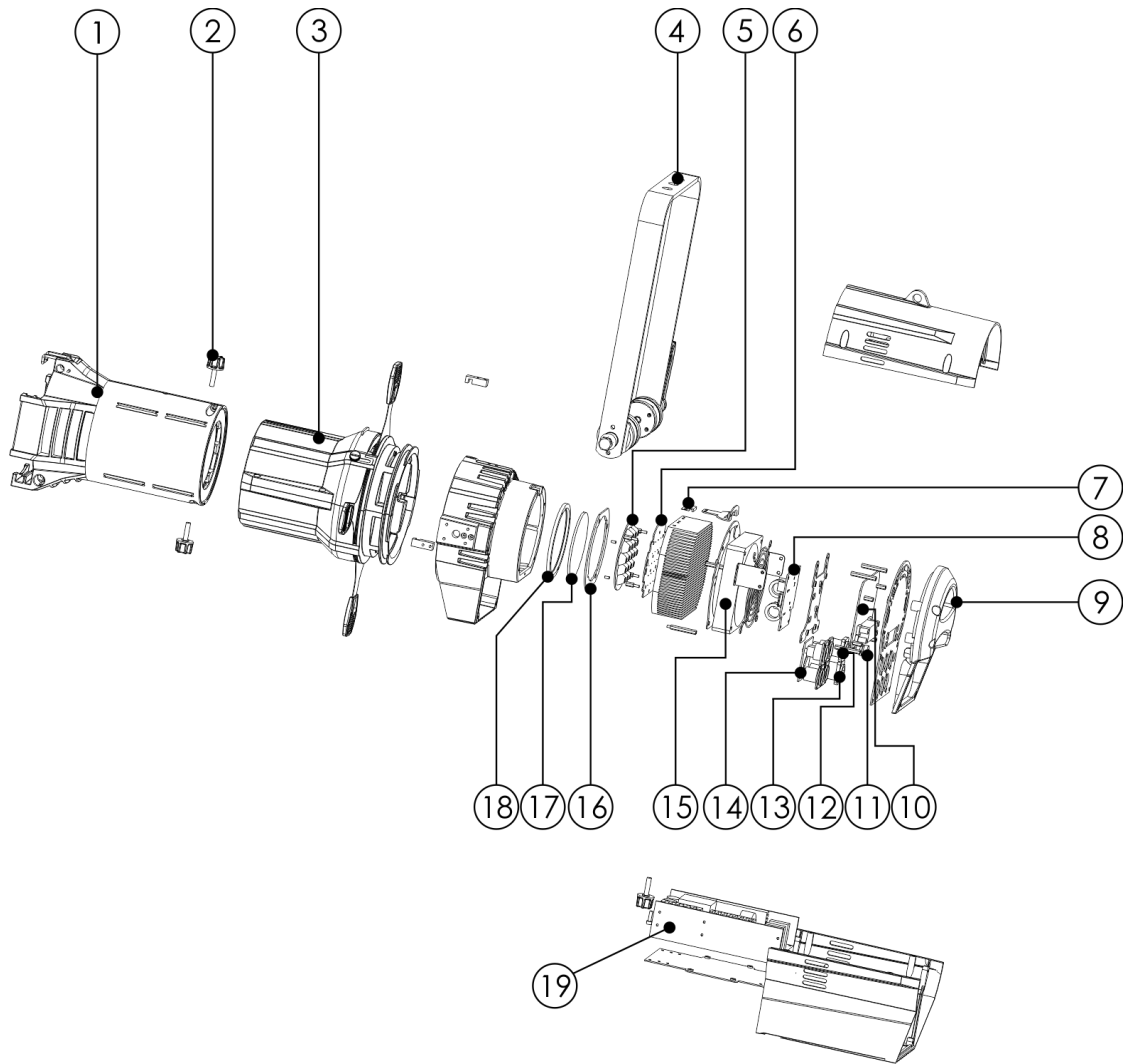

Fig. 02

- 01) Lens tube
- 02) Beam focus control
- 03) Barrel
- 04) Mounting bracket
- 05) LED lens
- 06) LED board
- 07) Thermal switch holder + thermal switch
- 08) Driver board
- 09) Insulated handle
- 10) PCB
- 11) Fuse T6,3AL/250V
- 12) PS socket
- 13) PS socket
- 14) PCB adapter
- 15) Cooling fan
- 16) Lens cover
- 17) Convex lens
- 18) Lens cover
- 19) Power supply

Backside

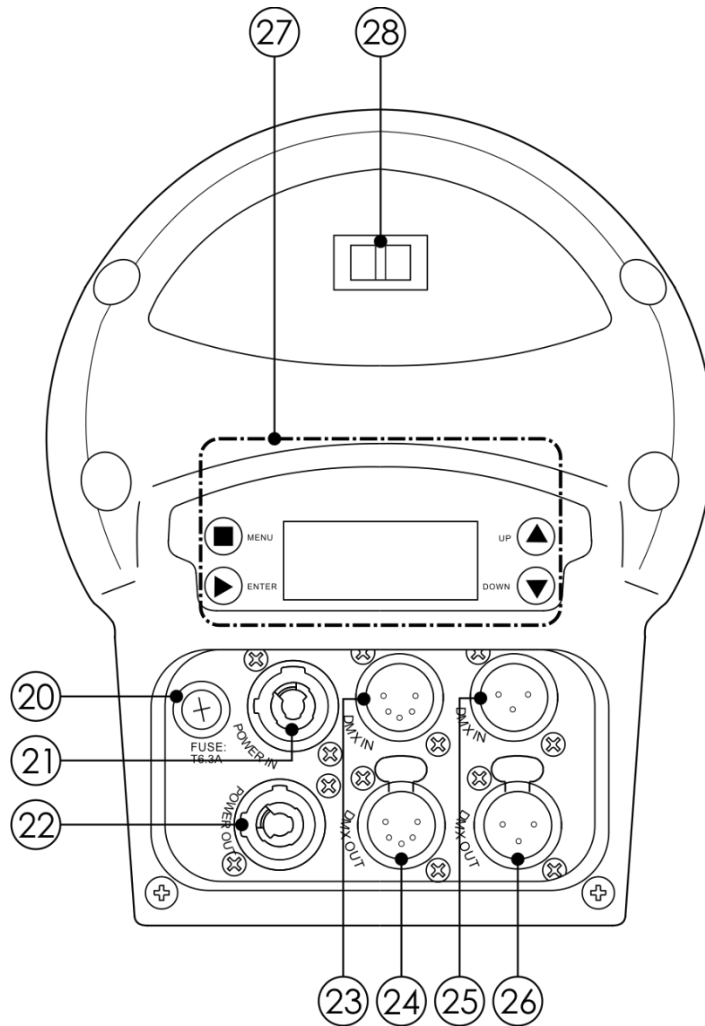

Fig. 03

- 20) Fuse T6,3AL/250V
- 21) Pro power connector Blue 100-240V IN
- 22) Pro power connector Gray 100-240V OUT
- 23) 5-pin DMX signal connector IN
- 24) 5-pin DMX signal connector OUT
- 25) 3-pin DMX signal connector IN
- 26) 3-pin DMX signal connector OUT
- 27) LCD display + control buttons
- 28) Input voltage switch 115V/230V

**Installation**

Remove all packing materials from the Performer Profile 600 MKII DDT. Check if all foam and plastic padding is removed. Connect all cables.

**Do not supply power before the whole system is set up and connected properly.**

**Always disconnect from electric mains power supply before cleaning or servicing.**

**Damages caused by non-observance are not subject to warranty.**

**Set Up and Operation**

Follow the directions below, as they pertain to your preferred operation mode.

Before plugging the unit in, always make sure that the power supply matches the product specification voltage. Do not attempt to operate a 120V specification product on 230V power, or vice versa.

Connect the device to the main power supply.

### Input Voltage Switch

Flick the voltage switch (28) to choose the desired input voltage: 115V or 230V.

### Lens Location

The different lenses used in the Performer are not interchangeable. When installing a new lens, refer to the illustration below for proper placement.

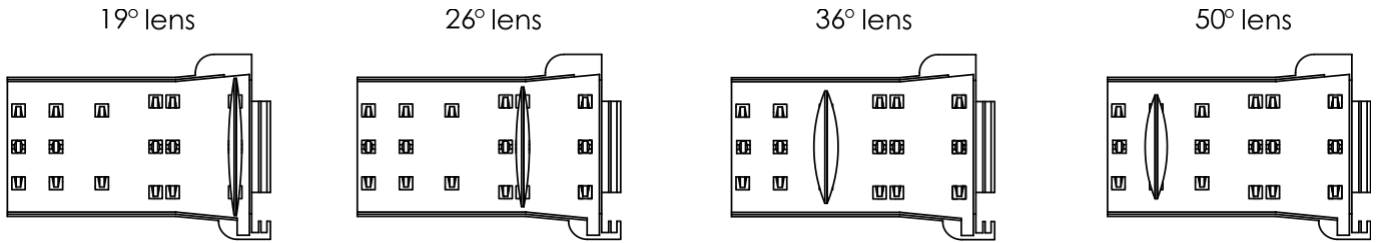

Fig. 04

### Focusing the Beam

- 01) Loosen the beam focus controls located under the barrel (fig. 05).
- 02) Slide the lens tube forwards or backwards to achieve the desired beam edge.
- 03) Once the fixture has been focused, tighten the beam focus controls.

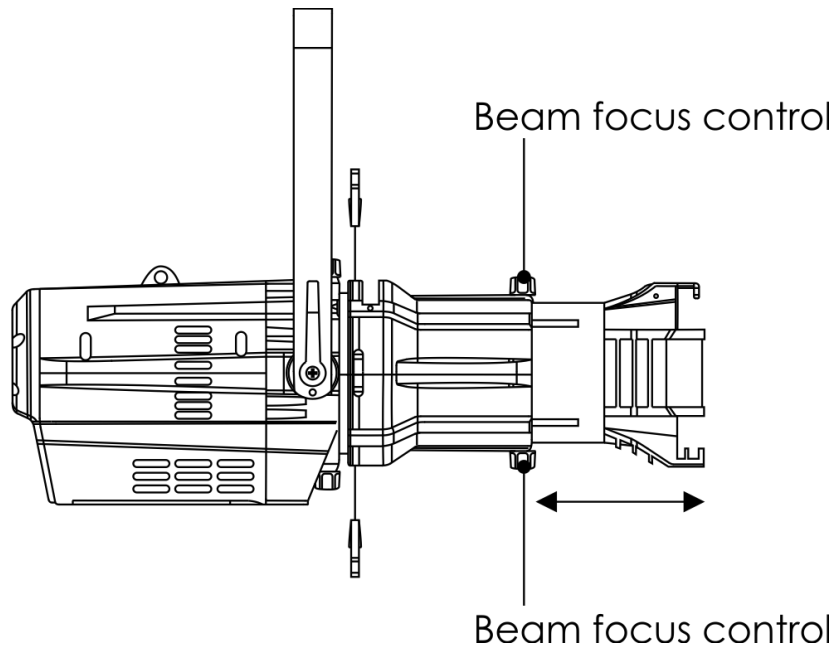

Fig. 05

**Color Frame Retaining Clip**

The color frame holder is equipped with a spring-loaded retaining clip. This prevents color frames and accessories from falling out (fig. 06).



**Make sure that all color frame accessories are locked in position with the retaining clip before hanging the Performer Profile 600 MKII DDT.**



- 01) Release the retaining clip by pushing it sideways while gently pulling backwards.
- 02) Insert the color frame(s).
- 03) Lock the retaining clip by pushing sideways while gently pushing forward.

Retaining clip in locked position

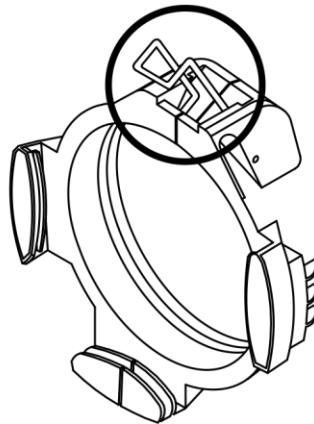

**Fig. 06**

**Color Notes**

The performance of saturated color gels is not guaranteed with low temperature ranges. For best results, always use a high quality and high temperature color gel. This product color extender may help increase your gel life. Contact your dealer for ordering information.

	Soft Focus Tube Retracted	Sharp Focus	Soft Focus Tube Extended
19°	W	B	B
26°	W	B	B
36°	B	B	W
50°	W	B	B

W: Worse gel life  
 B: Better gel life

**Shaping the Beam**

You may shape the beam with the shutters, a pattern, an optional drop-in iris or by rotating the barrel.

## Shutters

The shutters are located inside the barrel. Move them back and forth to modify the shape of the beam.

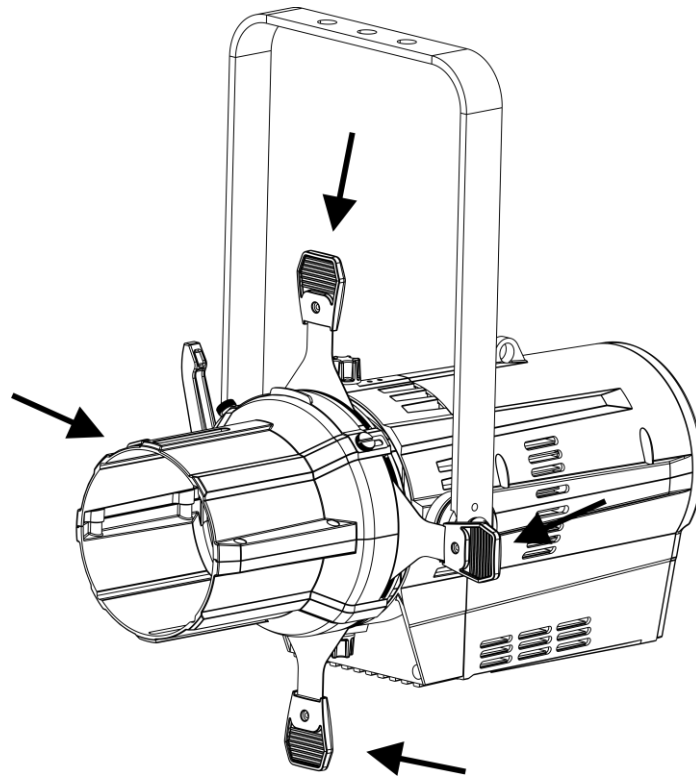

Fig. 07

## Drop-in Iris Slot

The Drop-in Iris slot is located on the top of the barrel. It accommodates either a drop-in iris or a motorized pattern device. When the slot is not in use, a small sheet metal cover, secured with 2 screws, prevents light leakage (fig. 08).

- 01) Use a screwdriver to loosen the screws on the drop-in iris slot cover. Do not remove the screws.
- 02) Slide the cover completely forward to expose the slot.
- 03) Insert the iris or a motorized pattern device. For an iris, install the flat side towards the shutters and make sure that the iris handle extends from the slot.
- 04) Slide the slot cover back towards the shutters, until it meets the iris handle. Leave enough space to move the iris handle.
- 05) Secure the drop-in iris slot cover by tightening the screws.

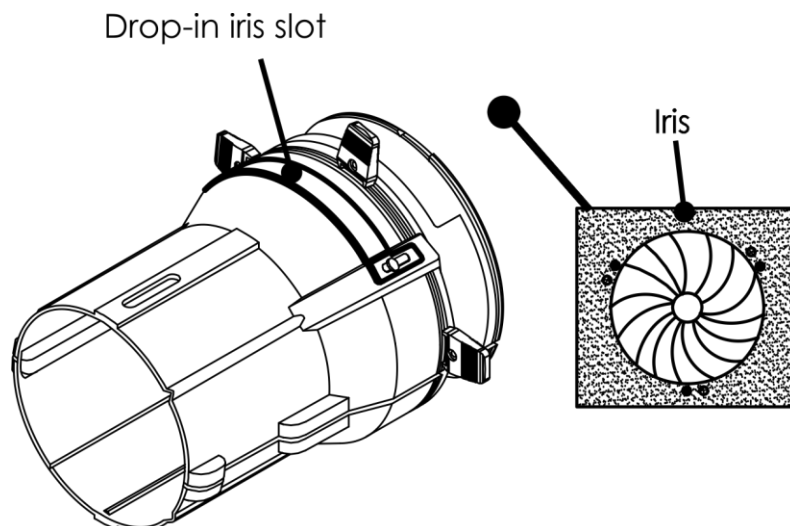
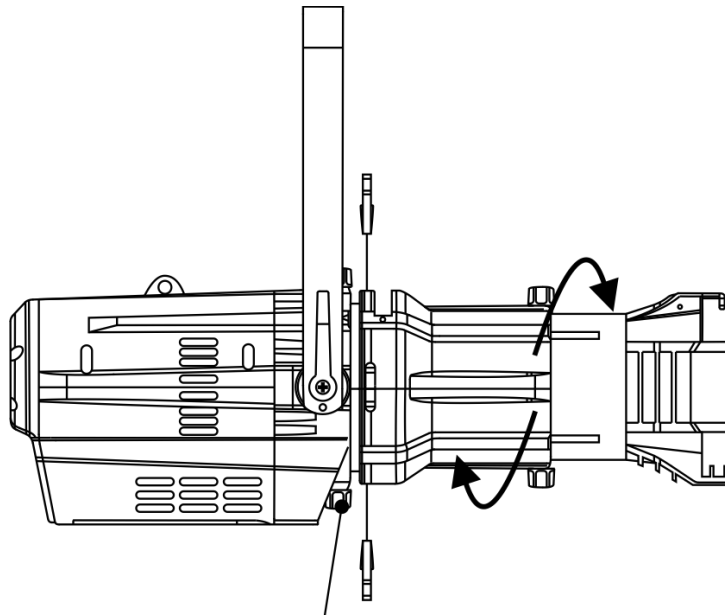

Fig. 08

### Rotating the Barrel Assembly

- 01) Loosen the barrel rotation control. It can be found directly behind the shutters on the underside of the reflector housing (fig. 09). **Do not remove the barrel rotation control.**
- 02) Rotate the barrel to the desired position.
- 03) Once the barrel is positioned, tighten the barrel's rotation control to lock it into position.



Barrel rotation control

Fig. 09

### Setting the Angle

- 01) Loosen the adjustment screw (do not remove it).
- 02) Tilt the fixture to the desired position (fig. 10).
- 03) Tighten the adjustment screw to secure the fixture in position.

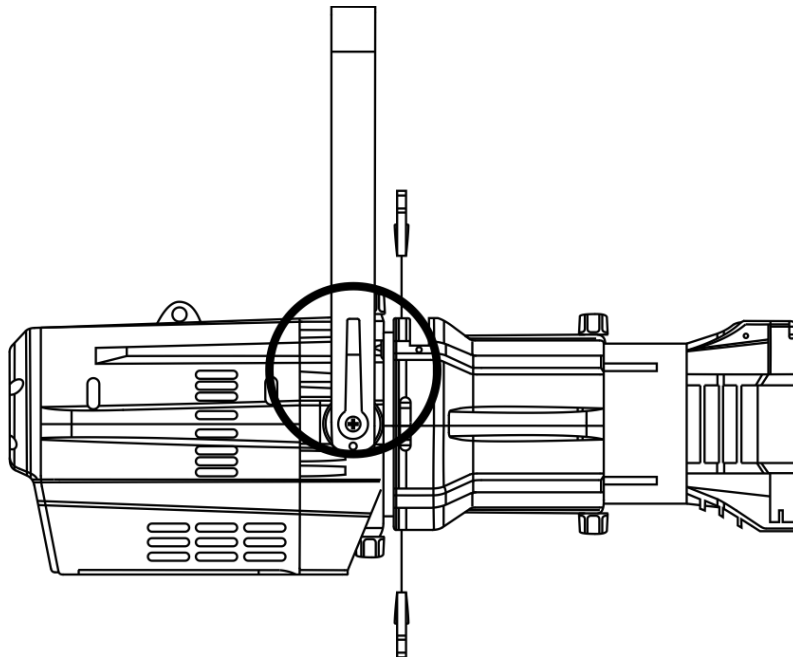

Fig. 10

## Control Modes

There are 3 modes:

- Stand-alone
- Master/Slave
- DMX-512 (1CH, 2CH, 3CH)

### One Performer (Stand-alone)

- 01) Fasten the effect light to a firm trussing. Leave at least 0,5 meter on all sides for air circulation.
- 02) Plug the end of the electric mains power cord into a proper electric power supply socket.
- 03) When the Performer is not connected with a DMX cable, it functions as a stand-alone device. Please see page 21 for more information about the Stand-alone mode.

### Multiple Performers (Master/Slave control)

- 01) Fasten the effect light onto firm trussing. Leave at least 0,5 meter on all sides for air circulation.
- 02) Use a 3-pin/5-pin XLR cable to connect the Performer.

The pins:



- 01) Earth
- 02) Signal -
- 03) Signal +

- 03) Link the units as shown in fig. 11. Connect the first unit's DMX "out" socket with the second unit's "in" socket, using a DMX signal cable. Repeat this process to link the second, third, and fourth units. You can use the same functions on the master device as described on page 21 (Stand-alone). This means that you can set your desired operation mode on the master device and all slave devices will react the same as the master device.

### Multiple Performers (Master/Slave control)

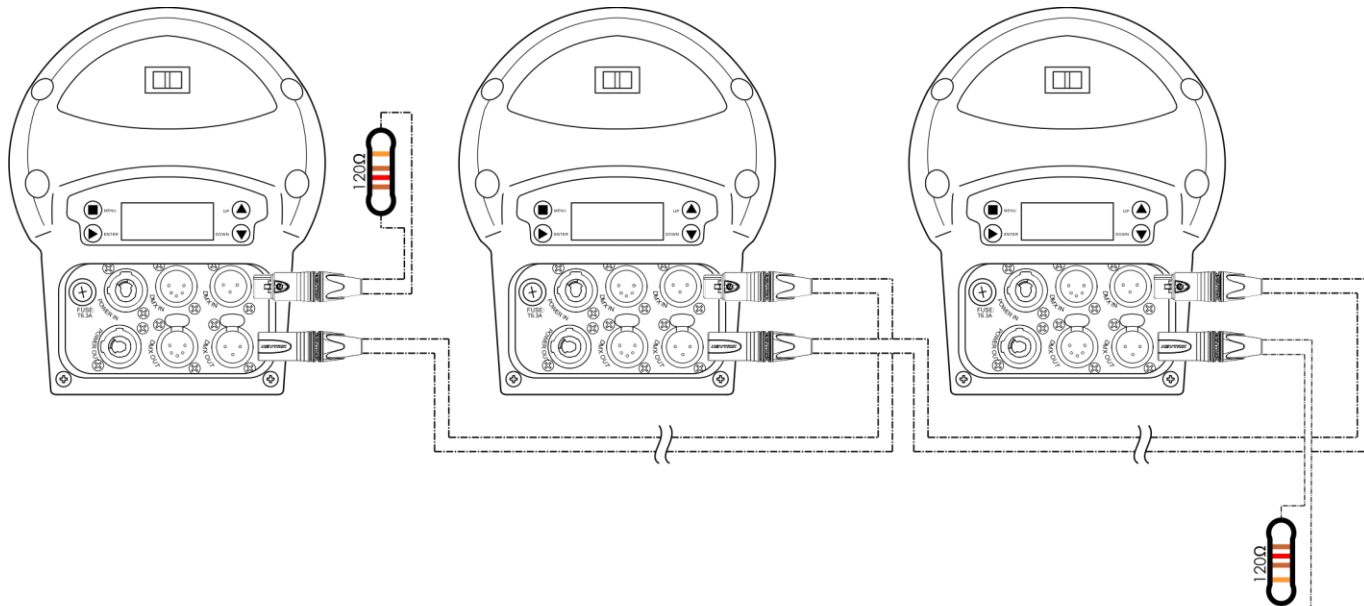
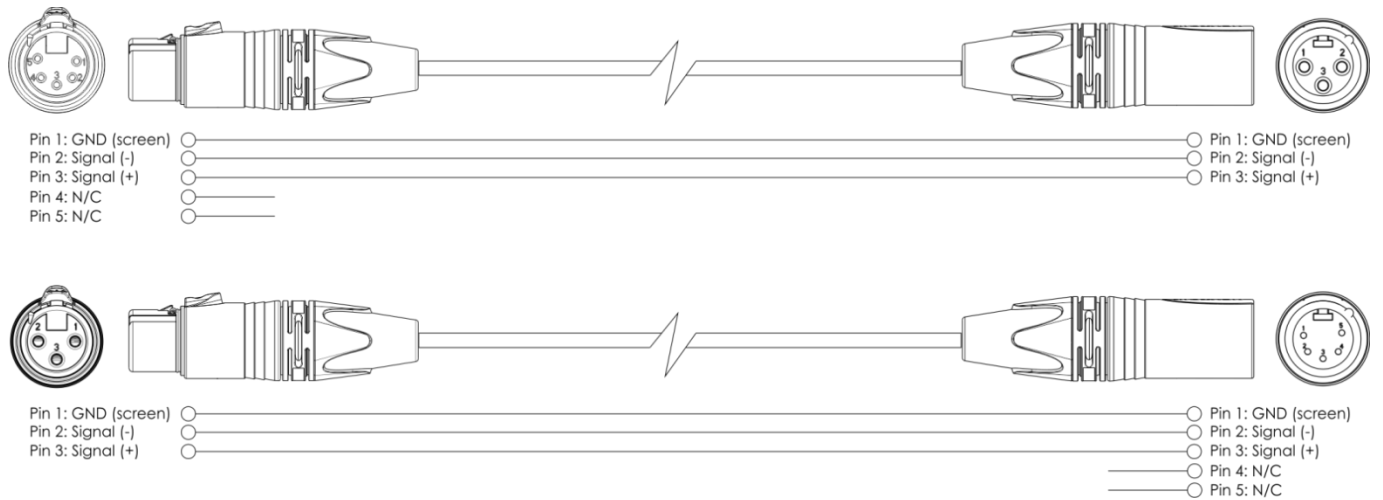

Fig. 11



**Multiple Performers (DMX Control)**

- 01) Fasten the effect light to a firm trussing. Leave at least 0,5 meter on all sides for air circulation.
- 02) Always use a safety cable (ordercode 70140 / 70141).
- 03) Use a 3-pin/5-pin XLR cable to connect the Performers and other devices.



- 04) Link the units as shown in fig. 12. Connect the first unit's DMX "out" socket with the second unit's "in" socket, using a DMX-signal cable. Repeat this process to link the second, third, and fourth units.
- 05) Supply electric power: Plug electric mains power cords into each unit's Pro power socket, then plug the other end of the mains power cord into proper electric power supply sockets, starting with the first unit. Do not supply power before the whole system is built and connected properly.

**Multiple Performers DMX Set Up**

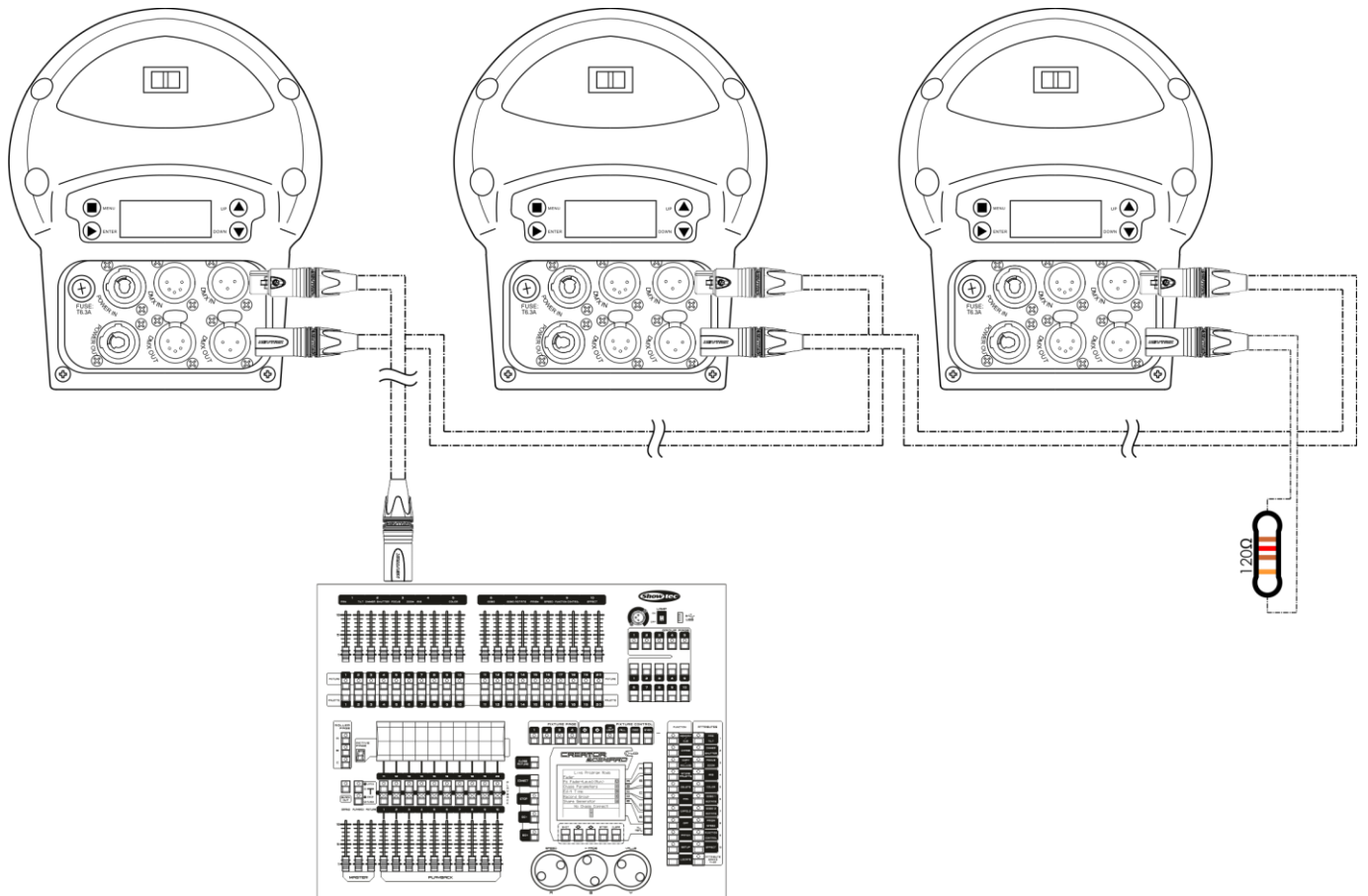

**Fig. 12**

**Note : Link all cables before connecting electric power**

## Fixture Linking

You will need a serial data link to run light shows of one or more fixtures using a DMX-512 controller or to run synchronized shows of two or more fixtures set to a master/slave operating mode. The combined number of channels required by all the fixtures on a serial data link determines the number of fixtures the data link can support.

- Important:** Fixtures on a serial data link must be daisy-chained in a single line. To comply with the EIA-485 standard, no more than 30 devices should be connected on one data link. Connecting more than 30 fixtures on one serial data link without the use of a DMX optically isolated splitter may result in deterioration of the digital DMX signal.
- 
- Maximum recommended DMX data link distance: 100 meters
  - Maximum recommended number of fixtures on a DMX data link: 30 fixtures
  - Maximum recommended number of fixtures on a power link @110V: 3 fixtures
  - Maximum recommended number of fixtures on a power link @230V: 7 fixtures

## Data Cabling

To link fixtures together, you must obtain data cables. You can purchase DAP Audio certified DMX cables directly from a dealer/distributor or construct your own cable. If you choose to create your own cable, please use data-grade cables that can carry a high quality signal and are less prone to electromagnetic interference.

### DAP Audio DMX Data Cables

- DAP Audio Basic microphone cable for allround use. bal. XLR/M 3-pin > XLR/F 3-pin. **Ordercode** FL01150 (1,5 m), FL013 (3 m), FL016 (6 m), FL0110 (10 m), FL0115 (15 m), FL0120 (20 m).
- DAP Audio X-type data cable XLR/M 3-pin > XLR/F 3-pin. **Ordercode** FLX0175 (0,75 m), FLX01150 (1,5 m), FLX013 (3 m), FLX016 (6 m), FLX0110 (10 m).
- DAP Audio cable for the demanding user with exceptional audio-qualities and connector made by Neutrik®. **Ordercode** FL71150 (1,5 m), FL713 (3 m), FL716 (6 m), FL7110 (10 m).
- DAP Audio cable for the demanding user with exceptional audio-qualities and connector made by Neutrik®. **Ordercode** FL7275 (0,75 m), FL72150 (1,5 m), FL723 (3 m), FL726 (6 m), FL7210 (10 m).
- DAP Audio 110 Ohm cable with digital signal transmission. **Ordercode** FL0975 (0,75 m), FL09150 (1,5 m), FL093 (3 m), FL096 (6 m), FL0910 (10 m), FL0915 (15 m), FL0920 (20 m).

The Performer Profile 600 MKII DDT can be operated with a controller in **control mode** or without the controller in **stand-alone mode**.

## Control Panel

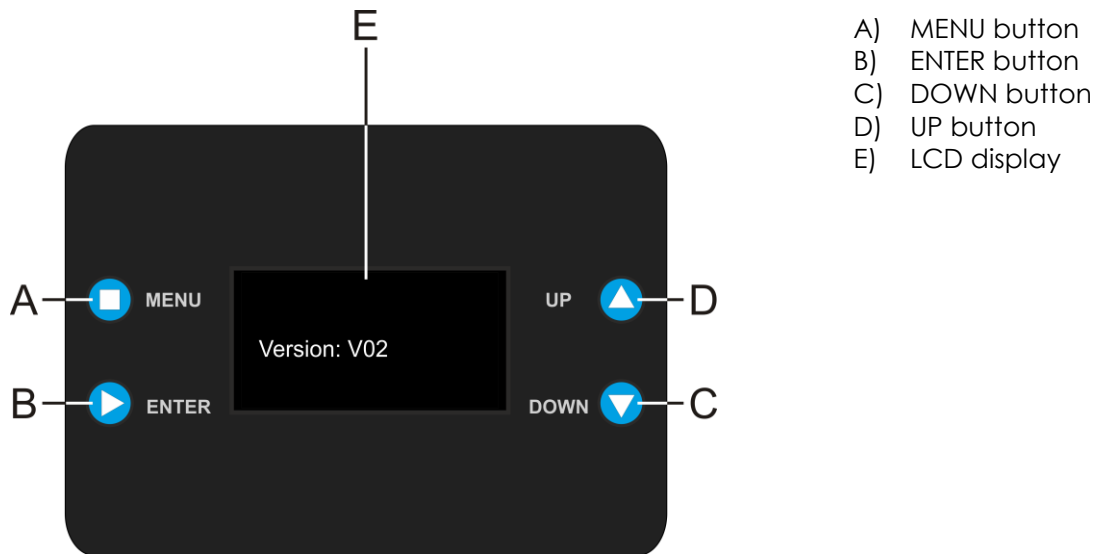

Fig. 13

## Control Mode

The fixtures are individually addressed on a data-link and connected to the controller. The fixtures respond to the DMX signal from the controller. (When you select the DMX address and save it, the controller will display the saved DMX address, next time.)

## DMX Addressing

The control panel on the front side of the base allows you to assign DMX fixture addresses, which is the first channel with which the Performer will respond to the controller.

Please note, when you use the controller, the unit has **3** channels.

When using multiple Performers, make sure you set the DMX addresses right.

Therefore, the DMX address of the first Performer should be **1(001)**; the DMX address of the second Performer should be **1+3=4 (004)**; the DMX address of the third Performer should be **4+3=7 (007)**, etc. Please, be sure that you do not have any overlapping channels in order to control each Performer correctly. If two or more Performers are addressed similarly, they will work similarly.

## Controlling:

After having addressed all Performer fixtures, you may now start operating these via your lighting controller.

**Note:** After switching on, the Performer will automatically detect whether DMX 512 data is received or not. If there is no data received at the DMX-input, the "LED" on the control panel will not flash.

If not, the problem may be:

- The XLR cable from the controller is not connected with the input of the Performer Profile 600 MKII DDT.
- The controller is switched off or defective, the cable or connector is defective, or the signal wires are swapped in the input connector.

**Note:** It is necessary to insert an XLR termination plug (with 120 Ohm) in the last fixture in order to ensure proper transmission on the DMX data link.

## ⚠ Display Off after 30 seconds ⚠

When no button is pressed for 30 seconds, the display will turn off.

To light up the display, you have to press the MENU, UP, DOWN or ENTER button.

Once you have pressed the button, the display will light up.

Menu Overview

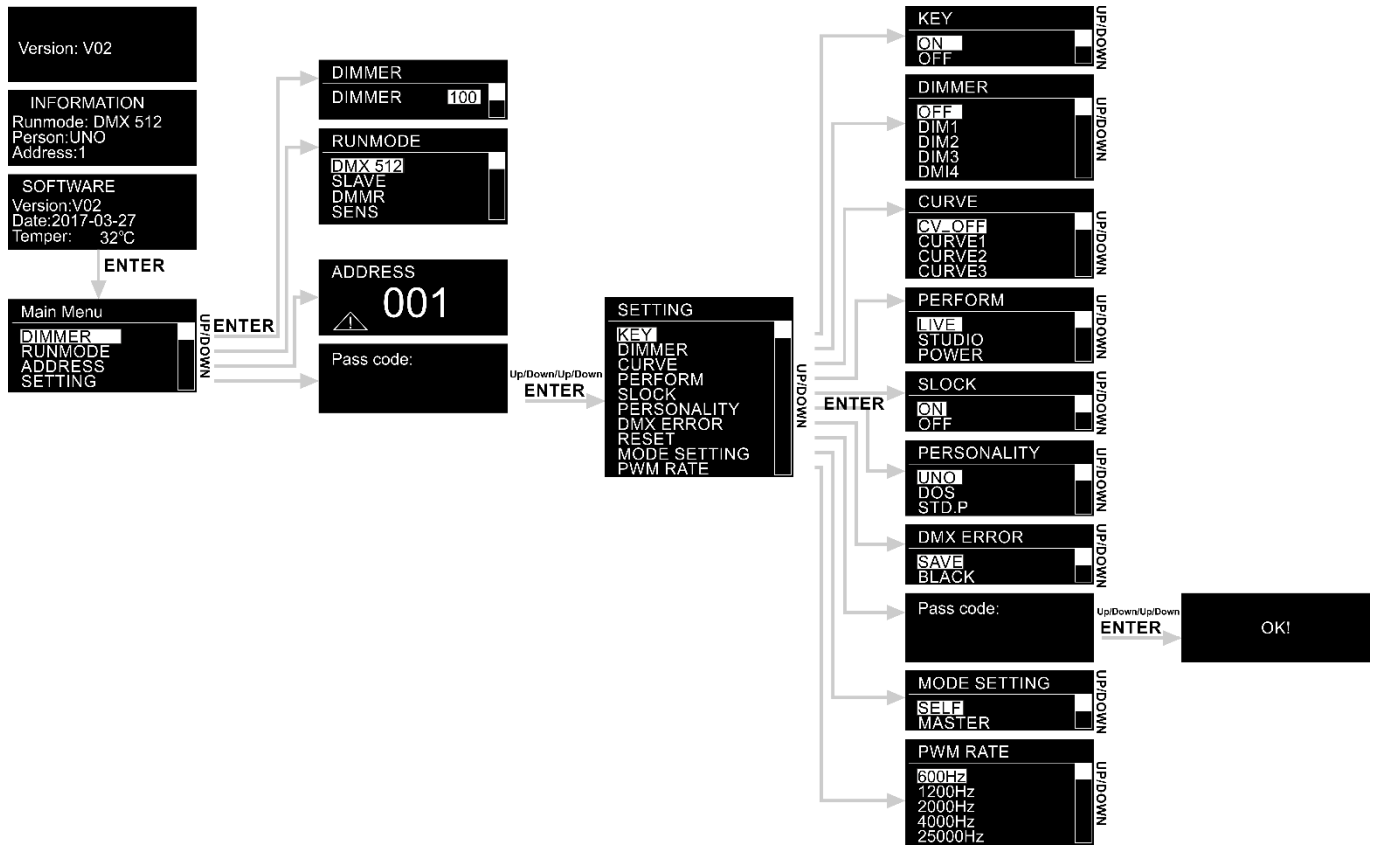

## Main Menu Options

01) On start-up, the display will show information about the device's current status:

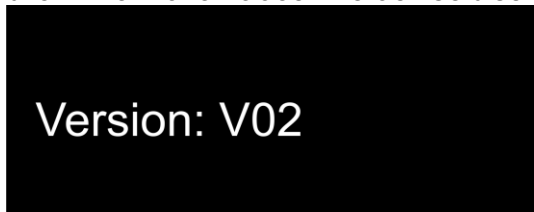

Version: V02

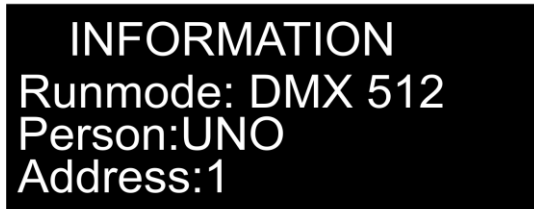

INFORMATION  
Runmode: DMX 512  
Person: UNO  
Address: 1



SOFTWARE  
Version: V02  
Date: 2017-03-27  
Temper: 32°C

02) Press the **ENTER** button to open the main menu.

03) Press the **UP/DOWN** buttons to toggle through the 4 main menu options:



Main Menu

DIMMER  
RUNMODE  
ADDRESS  
SETTING

04) Press the **ENTER** button to open the desired submenu.

### 1. Dimmer

With this menu you can manually adjust the dimmer intensity.



DIMMER

DIMMER 100

01) While in main menu, press the **UP/DOWN** buttons until the display shows **DIMMER**.

02) Press the **ENTER** button to open the menu.

03) Press the **UP/DOWN** buttons to adjust the intensity of the dimmer. The adjustment range is between 0-100.

## 2. Run Mode

In this mode you can set the desired operation mode.

- 01) While in main menu, press the **UP/DOWN** buttons until the display shows **RUNMODE**.
- 02) Press the **ENTER** button to open the menu.
- 03) Press the **UP/DOWN** buttons to toggle through the 4 options:
  - **DMX 512**
  - **SLAVE**
  - **DMMR**
  - **SENS**
- 04) When the display shows **DMX 512**, the Performer will become a master device and will utilize the DMX protocol to determine its performance.
- 05) When the display shows **SLAV**, the Performer will become a slave device and will react the same as the master device.
- 06) When the display shows **DMMR** and the Performer is connected to a triac, DMX will not function and dimming will be possible only by means of your triac.
- 07) When the display shows **SENS**, two situations may occur:
  - When the power supply reaches 80% of the nominal voltage and a DMX signal is received, the Performer will be controlled by DMX.
  - When the power supply is below 80% of the nominal voltage and there is not any DMX signal, the Performer will switch to Triac mode.

## 3. Address

With this menu you can set the desired DMX starting address.



- 01) Press the **UP/DOWN** buttons to set the desired DMX starting address. The adjustment range is between 001-512.

## 4. Setting

In this menu you can adjust the device's special settings.

- 01) While in main menu, press the **UP/DOWN** buttons until the display shows **SETTING**.
- 02) Press the **ENTER** button to open the menu.
- 03) The display will show PASS CODE and you will need to insert a **key combination** which will **unlock this hidden menu**. To do so, **press the buttons in the following order: UP, DOWN, UP, DOWN, ENTER**.
- 04) Press the **UP/DOWN** buttons to toggle through the following options:

<b>KEY</b>	Safety key
<b>DIMMER</b>	Dimmer speed
<b>CURVE</b>	Dimming curve settings
<b>PERFORM</b>	Performance settings
<b>SLOCK</b>	Settings menu safety lock
<b>PERSONALITY</b>	DMX channel modes
<b>DMX ERROR</b>	Save DMX/Blackout
<b>RESET</b>	Reset settings
<b>MODE SETTING</b>	DMX data transfer
<b>PWM RATE</b>	Refresh rate

4.1. Safety Key

- 01) When the display shows **KEY**, press the **ENTER** button to open the menu.
- 02) Press the **UP/DOWN** buttons to toggle between **ON** and **OFF** to activate/deactivate the safety lock.
- 03) When the option is **active**, you will need to insert the safety key combination every time the display turns off.
- 04) When the option is **inactive**, the Settings menu will not get locked, providing that the device remains in it.
- 05) If the display shows **SETTING** and turns off after 30 seconds – you will need to re-insert the safety key.

4.2. Dimmer Speed

- 01) When the display shows **DIMMER**, press the **ENTER** button to open the menu.
- 02) Press the **UP/DOWN** buttons to toggle through the 5 options:  
**OFF** Dimmer Speed OFF

**DIM1-DIM 4** Dimmer speed, from fast to slow

4.3. Dimming Curve Settings

- 01) When the display shows **CURVE**, press the **ENTER** button to open the menu.
- 02) Press the **UP/DOWN** buttons to choose the desired dimming curve out of the 4 available options:

Dimming curves

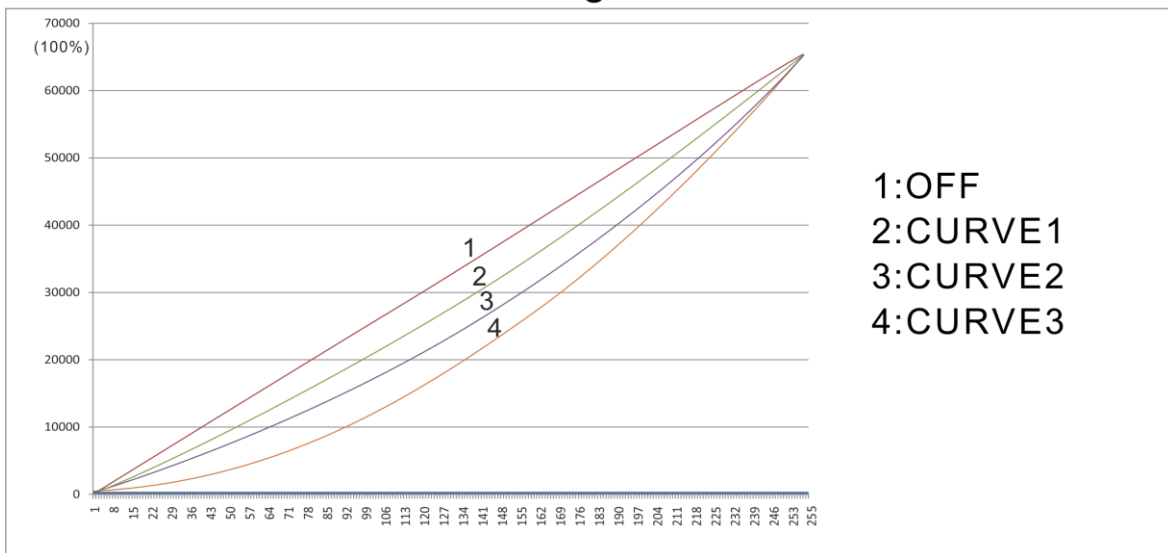

4.4. Performance Settings

- 01) When the display shows **PERFORM**, press the **ENTER** button to open the menu.
- 02) Press the **UP/DOWN** buttons to toggle through the 3 modes:

**LIVE** Default mode. It provides a compromise between output quality and noise level.

**STUDIO** Noise level-oriented mode. It emits little noise and operates at moderate power level.

**POWER** Output-oriented mode. The device does not offer any consideration for noise level and operates at full power.

4.5. Settings Menu Safety Lock

- 01) When the display shows **SLOCK**, press the **ENTER** button to open the menu.
- 02) Press the **UP/DOWN** buttons to toggle between **ON** and **OFF** to activate/deactivate the menu lock.
- 03) When the option is **active**, you will always need to insert the safety key/pass code in attempt to enter the Settings menu.

#### **4.6. DMX Channel Modes**

With this menu you can set the desired DMX channel mode.

- 01) When the display shows **PERSONALITY**, press the **ENTER** button to open the menu.
- 02) Press the **UP/DOWN** buttons to toggle through the 3 channel modes:  
**UNO**                                    1-channel mode  
  
**DOS**                                    2-channel mode  
  
**STD.P**                                   3-channel mode

#### **4.7. Save DMX/Blackout**

- 01) When the display shows **DMX ERROR**, press the **ENTER** button to open the menu.
- 02) Press the **UP/DOWN** buttons to toggle between the 2 options:  
**SAVE**                                    DMX data save  
  
**BLACK**                                    Blackout
- 03) If the display shows **SAVE**, the Performer will utilize the last working DMX signal, which will ensure uninterrupted performance.
- 04) If the display shows **BLACK**, the Performer will black out the output, in case of a DMX signal error.

#### **4.8. Reset Settings**

- 01) When the display shows **RESET**, press the **ENTER** button to enter the menu. The display will show PASS CODE.
- 02) Insert the safety key combination by pressing the buttons in the following order: **UP, DOWN, UP, DOWN, ENTER**.
- 03) The display will promptly show **OK!** and the settings will have been reset.

#### **4.9. Mode Setting**

- 01) When the display shows **MODE SETTING**, press the **ENTER** button to open the menu.
- 02) Press the **UP/DOWN** buttons to toggle between the 2 options:  
**SELF**                                    DMX data transfer OFF  
  
**MASTER**                                    DMX data transfer ON
- 03) If the display shows **SELF**, the Performer will not send DMX data to the other connected devices.
- 04) If the display shows **MASTER**, the Performer will send DMX data to the other connected devices.

#### **4.10. Refresh Rate**

- 01) When the display shows **PWM RATE**, press the **ENTER** button to open the menu.
- 02) Press the **UP/DOWN** buttons to toggle through the 5 options:  
**600Hz**  
**1200Hz**  
**2000Hz**  
**4000Hz**  
**25000Hz**

- Note:**
- When the refresh rate is increased, the gray scale dimmer rate will be reduced (that means that the dimmer resolution will decrease when refresh rate is increased).
  - When the PWM rate is 4000Hz, CURVE3 is invalid (see page 22).
  - When the PWM rate is 25000Hz, CURVE1, CURVE2 and CURVE3 are invalid.

You need to decrease the PWM rate to increase the gray rate.



## DMX Channels

### 1 Channel (UNO)

#### Channel 1 – Dimmer

0-255      0-100% dimmer

### 2 Channels (DOS)

#### Channel 1 – Dimmer

0-255      0-100% dimmer

#### Channel 2 – Fine dimmer CH1 must be open.

0-255      Fine dimmer adjustment

### 3 Channels (STD.P)

#### Channel 1 – Dimmer

0-255      0-100% dimmer

#### Channel 2 – Fine dimmer CH1 must be open.

0-255      Fine dimmer adjustment

#### Channel 3 – Strobe CH1 must be open.

0-9      Strobe OFF

10-99      Strobe ON, from low to high frequency

100-109      Strobe OFF

110-179      Pulse strobe ON, from low to high frequency

180-189      Strobe OFF

190-255      Random strobe, from low to high frequency

## Cleaning

---

Please follow the next recommendations when cleaning and inspecting lenses and reflectors:

Do not use glass or window type cleaners on lenses (glass or polymer) or reflectors.

Do not use abrasive materials such as steel wool.

Replace lenses if they contain visible damage (cracks or deep scratches) which that may impair their effectiveness.

### Cleaning 19°, 26°, 36° and 50° glass lenses

- 01) Remove the beam focus controls at the bottom of the barrel. Remove the lens tube from the barrel.
- 02) Dampen a clean lint-free cloth with vinegar or household ammonia. You may also use water, but it will leave spots that can be removed by gently polishing the lens with a clean and dry cloth.
- 03) Starting from the center, gently wipe the lens.
- 04) Slide the lens tube back into the barrel with the color frame-retaining clip on top. Replace the beam focus controls.

### Cleaning the Reflector



**Unplug the fixture before attempting to clean the reflector. To quickly clean the reflector, remove the lens tube and clean the dust from the reflector with a blast of oil-free air.**



**You may also wipe the reflector with a clean lint-free cloth. If either method is not sufficient, follow the instructions below. You will need a screwdriver to complete this procedure.**

- 01) Remove the barrel rotation controls located at the bottom of the barrel. Use a screwdriver to remove the retainer bolt located on top of the reflector housing.
- 02) Rotate the barrel by 45° in either direction. Carefully remove the barrel from the reflector housing.
- 03) Dampen a clean lint-free cloth with alcohol or distilled water (alcohol is recommended).
- 04) Gently wipe the reflector.
- 05) Insert the barrel into the reflector housing with the iris/pattern slot on top (line up the triangles on both parts).
- 06) While pressing in gently, rotate the barrel by 45° clockwise until it sets into position. Then, rotate the barrel counterclockwise 45°. The barrel should be firmly attached and the triangles should line up again.
- 07) Replace the barrel rotation controls and tighten the retainer bolt.

## Maintenance

---

The operator has to make sure that safety-related and machine-technical installations are to be inspected by an expert after every year in the course of an acceptance test.

The operator has to make sure that safety-related and machine-technical installations are to be inspected by a skilled person once a year.

The following points have to be considered during the inspection:

- 01) All screws used for installing the device or parts of the device have to be tightly connected and must not be corroded.
- 02) There may not be any deformations on housings, fixations and installation spots.
- 03) Mechanically moving parts like axles, eyes and others may not show any traces of wearing.
- 04) The electric power supply cables must not show any damages or material fatigue.

The Performer Profile 600 MKII DDT requires almost no maintenance. However, you should keep the unit clean. Otherwise, the fixture's light output will be significantly reduced. Disconnect the mains power supply, and then wipe the cover with a damp cloth. Do not immerse in liquid. Wipe lens clean with glass cleaner and a soft cloth. Do not use alcohol or solvents.

The front lens will require weekly cleaning, as smoke-fluid tends to build up residues, reducing the light output very quickly.

Please clean internal components once a year with a light brush and vacuum cleaner.

Keep connections clean. Disconnect electric power, and then wipe the DMX and audio connections with a damp cloth. Make sure connections are thoroughly dry before linking equipment or supplying electric power.

## Replacing the Fuse

Power surges, short-circuit or inappropriate electrical power supply may cause a fuse to burn out. If the fuse burns out, the product will not function whatsoever. If this happens, follow the directions below:

- 01) Unplug the unit from electric power source.
- 02) Insert a flat-head screwdriver into a slot in the fuse cover. Turn the screwdriver to the left, at the same time gently push a bit (Turn and Push). The fuse will come out.
- 03) Remove the used fuse. If brown or unclear, it is burned out.
- 04) Insert the replacement fuse into the holder where the old fuse was. Reinsert the fuse cover. Be sure to use a fuse of the same type and specification. See the product specification label for details.

## Troubleshooting

---

This troubleshooting guide is meant to help solve simple problems.

If a problem occurs, carry out the steps below in sequence until a solution is found. Once the unit operates properly, do not carry out following steps.

### No Light

If the light effect does not operate properly, refer servicing to a technician.

Suspect three potential problem areas as: the power supply, the LEDs, the fuse.

- 01) Power supply. Check if the unit is plugged into an appropriate power supply.
- 02) The LEDs. Return the Performer to your Showtec dealer.
- 03) The fuse. Replace the fuse. See page 26 for replacing the fuse.
- 04) If all of the above appears to be O.K., plug the unit in again.
- 05) If you are unable to determine the cause of the problem, do not open the Performer, as this may damage the unit and the warranty will become void.
- 06) Return the device to your Showtec dealer.

**No Response to DMX**

Suspect the DMX cable or connectors, a controller malfunction, a light effect DMX card malfunction.

- 01) Check the DMX setting. Make sure that DMX addresses are correct.
- 02) Check the DMX cable: Unplug the unit; change the DMX cable; then reconnect to electrical power. Try your DMX control again.
- 03) Determine whether the controller or light effect is at fault. Does the controller operate properly with other DMX products? If not, take the controller in for repair. If so, take the DMX cable and the light effect to a qualified technician.

<b>Problem</b>	<b>Probable cause(s)</b>	<b>Solution</b>
One or more fixtures do not function at all	No power to the fixture	<ul style="list-style-type: none"> <li>• Check if power is switched on and cables are plugged in</li> </ul>
	Primary fuse blown	<ul style="list-style-type: none"> <li>• Replace fuse</li> </ul>
Fixtures reset correctly, but all respond erratically or not at all to the controller	The controller is not connected.	<ul style="list-style-type: none"> <li>• Connect controller</li> </ul>
	3-pin/5-pin XLR Out of the controller does not match XLR Out of the first fixture on the link (i.e. signal is reversed)	<ul style="list-style-type: none"> <li>• Install a phase reversing cable between the controller and the first fixture on the link</li> </ul>
Fixtures reset correctly, but some respond erratically or not at all to the controller	Poor data quality	<ul style="list-style-type: none"> <li>• Check data quality. If much lower than 100 percent, the problem may be a bad data link connection, poor quality or broken cables, missing termination plug, or a defective fixture disturbing the link</li> </ul>
	Bad data link connection	<ul style="list-style-type: none"> <li>• Inspect connections and cables. Correct poor connections. Repair or replace damaged cables</li> </ul>
	Data link not terminated with 120 Ohm termination plug	<ul style="list-style-type: none"> <li>• Insert termination plug in output jack of the last fixture on the link</li> </ul>
	Incorrect addressing of the fixtures	<ul style="list-style-type: none"> <li>• Check address setting</li> </ul>
	One of the fixtures is defective and disturbs data transmission on the link	<ul style="list-style-type: none"> <li>• Bypass one fixture at a time until normal operation is restored: unplug both connectors and connect them directly together.</li> <li>• Have the defective fixture serviced by a qualified technician</li> </ul>
	3-pin/5-pin XLR Out on the fixtures does not match (pins 2 and 3 reversed)	<ul style="list-style-type: none"> <li>• Install a phase-reversing cable between the fixtures or swap pin 2 and 3 in the fixture that behaves erratically</li> </ul>
No light or LEDs cut out intermittently	Fixture is too hot	<ul style="list-style-type: none"> <li>• Allow the fixture to cool down</li> <li>• Clean the fan</li> <li>• Make sure air vents and the front lens are not blocked</li> <li>• Turn up the air conditioning</li> </ul>
	LEDs damaged	<ul style="list-style-type: none"> <li>• Disconnect the fixture and return it to your dealer</li> </ul>
	The power supply settings do not match local AC voltage and frequency	<ul style="list-style-type: none"> <li>• Disconnect fixture. Check settings and correct if necessary</li> </ul>

## Product Specifications

Model:	Showtec Performer Profile 600 MKII DDT
Input voltage:	100-240V AC, 50/60Hz
Power consumption:	250W (full output)
DMX linking:	30pcs
Fuse:	T6,3AL/250V
Dimensions:	480 x 290 x 462 mm (LxWxH)
Weight:	8,2 kg
<b>Operating and Programming:</b>	
Signal pin OUT:	Pin 1 (earth), pin 2 (-), pin 3 (+)
DMX mode:	1, 2, 3 channels
Signal input:	3-pin/5-pin XLR IN
Signal output:	3-pin/5-pin XLR OUT
<b>Electro-mechanical effects:</b>	
Light source:	19 x 10W LED
Light output:	6522 Lumen
Peak intensity:	71900cd
Color rendering:	>90Ra
Color temperature:	3200K
Dimmer:	0-100%
Strobe:	0-20Hz
Dimming curves:	Dimm4 technology, 4 presets
Dimming resolution:	16-bit
Refresh rate:	1200Hz
Housing:	Die-cast aluminum
DMX control:	via standard DMX controller
Onboard:	LCD display for easy setup
Control:	Stand-alone, Master/Slave, DMX
Connections:	3-pin/5-pin DMX signal connectors IN/OUT, Pro power connectors IN/OUT
IP rating:	IP20
Cooling:	Internal fan
Max. ambient temperature $t_a$ :	40°C
Max. housing temperature $t_B$ :	80°C
<b>Minimum distance:</b>	
Minimum distance from flammable surfaces:	0,5 m
Minimum distance to lighted object:	1 m

Design and product specifications are subject to change without prior notice.



Website: [www.Showtec.info](http://www.Showtec.info)

Email: [service@highlite.nl](mailto:service@highlite.nl)

## Dimensions

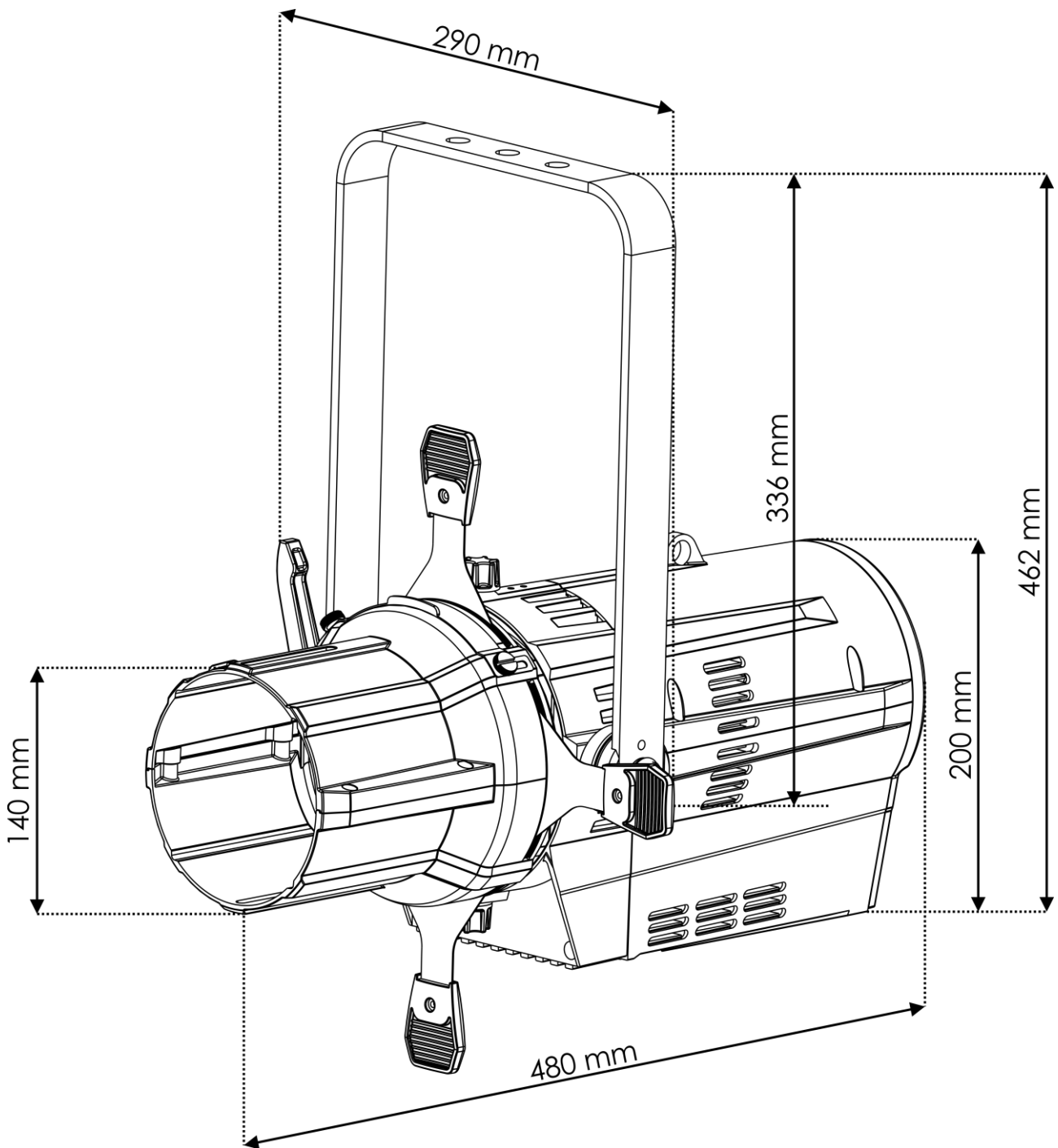





©2017 Showtec