

WIRELESS SOLUTION
MADE IN SWEDEN



W-DMX G4

BlackBox and WhiteBox F-1

BlackBox and WhiteBox R-512

BlackBox and WhiteBox F-2

Micro F-1 Lite

Micro R-512 Lite

ProBox F-2500

User Manual

G4
W-DMX™ GENERATION IV

W-DMX G4 User Manual

Issue date: 2012-02

Edition: 1

Subject to modifications.

All trademarks referenced are trademarks or registered trademarks of their respective owners, whose protected rights are acknowledged.

Copyright Wireless Solution Sweden Sales AB

Wireless Solution Sweden Sales AB
Stureparksvägen 7
451 55 Uddevalla
Sweden
Tel.: +46 522 511 511
Fax: +46 522 440 885
E-Mail: helpdesk@wirelessdmx.com
Web: www.wirelessdmx.com

Contents

1	Your Wireless DMX G4 system (W-DMX G4)	7
2	The W-DMX technology	8
3	About this document	10
3.1	Target group of this document	10
3.2	Signs and symbols in this document	10
4	BlackBox and WhiteBox F-1	11
4.1	Scope of delivery	11
4.1.1	BlackBox	11
4.1.2	WhiteBox	11
4.2	Connectors and ports	12
4.2.1	BlackBox	12
4.2.2	WhiteBox	13
4.3	LEDs	14
4.4	Installing the unit	15
4.4.1	BlackBox	15
4.4.2	WhiteBox	16
4.5	Switching FLEX modes	17
4.6	Operation as a transmitter	18
4.6.1	Prerequisites for successful linking with receivers	18
4.6.2	Linking receivers	19
4.6.3	Unlinking all receivers	20
4.7	Operation as a receiver	21
4.7.1	Linking with transmitters	21
4.7.2	Unlinking from transmitters	21
4.8	Switching CTRL modes	21
5	BlackBox and WhiteBox R-512	23
5.1	Scope of delivery	23
5.1.1	BlackBox	23
5.1.2	WhiteBox	23
5.2	Connectors and ports	23
5.2.1	BlackBox	23
5.2.2	WhiteBox	24

5.3	LEDs	24
5.4	Installing the unit	24
5.5	Operation as a receiver	24
6	BlackBox and WhiteBox F-2	25
6.1	Scope of delivery	25
6.1.1	BlackBox	25
6.1.2	WhiteBox	25
6.2	Connectors and ports	25
6.2.1	BlackBox	25
6.2.2	WhiteBox	27
6.3	LEDs	28
6.4	Installing the unit	29
6.5	Switching FLEX modes	29
6.6	Operation as a transmitter	30
6.7	Operation as a receiver	30
6.8	Switching CTRL modes	30
7	Micro units	31
7.1	Micro F-1 Lite	31
7.1.1	Scope of delivery	31
7.1.2	Connectors and ports	31
7.1.3	LEDs	32
7.1.4	Installing the unit	32
7.1.5	Switching FLEX modes	32
7.1.6	Operation as a transmitter	32
7.1.7	Operation as a receiver	32
7.1.8	Switching CTRL modes	33
7.1.9	Battery option	33
7.2	Micro R-512 Lite	34
7.2.1	Scope of delivery	34
7.2.2	Connectors and ports	34
7.2.3	LEDs	35
7.2.4	Installing the unit	35
7.2.5	Operation as a receiver	35
7.2.6	Switching CTRL modes	35

8	ProBox F-2500	36
8.1	Scope of delivery.....	36
8.2	Connectors and ports.....	36
8.3	LEDs	37
8.4	Installing the unit	37
8.5	Switching FLEX modes	37
8.6	Operation as a transmitter.....	37
8.7	Operation as a receiver.....	38
8.8	Switching CTRL modes.....	38
9	Technical data	39
9.1	BlackBoxes (BB) and WhiteBoxes (WB) F-1, R-512 and F-2.....	39
9.2	MicroBox F-1 Lite and MicroBox R-512 Lite.....	41
9.3	ProBox F-2500	43

1 Your Wireless DMX G4 system (W-DMX G4)

Thank you for purchasing the Wireless DMX G4 system (W-DMX G4), the industry's leading system for transmitting and receiving DMX signals reliably.

There are two operating modes for W-DMX G4 units, depending on which units you have purchased:

- W-DMX G4 Receivers to receive W-DMX signals (denoted with an R in their product model name)
- W-DMX G4 Transmitters to transmit or repeat W-DMX signals (denoted with an F in their product model name)

G4 Transmitters (or 'Flex' model units) can be changed over to Receive Mode with the procedure described in chapter "4.5 Switching FLEX modes", page 17.

W-DMX units are available in four different series:

- BlackBox MK I / MK II
- WhiteBox
- MicroBox
- ProBox

The series you have purchased are marked on the outside of the unit's packaging.

2 The W-DMX technology

2 The W-DMX technology

W-DMX technology is the core of all our products. W-DMX is specifically engineered by Wireless Solution Sweden AB to provide the same quality, reliability and performance as in any hardwired DMX data link.

W-DMX gives you even greater freedom to create reliable point-to-point, point-to-multipoint and even multipoint-to-multipoint installations over large distances and in any environment.

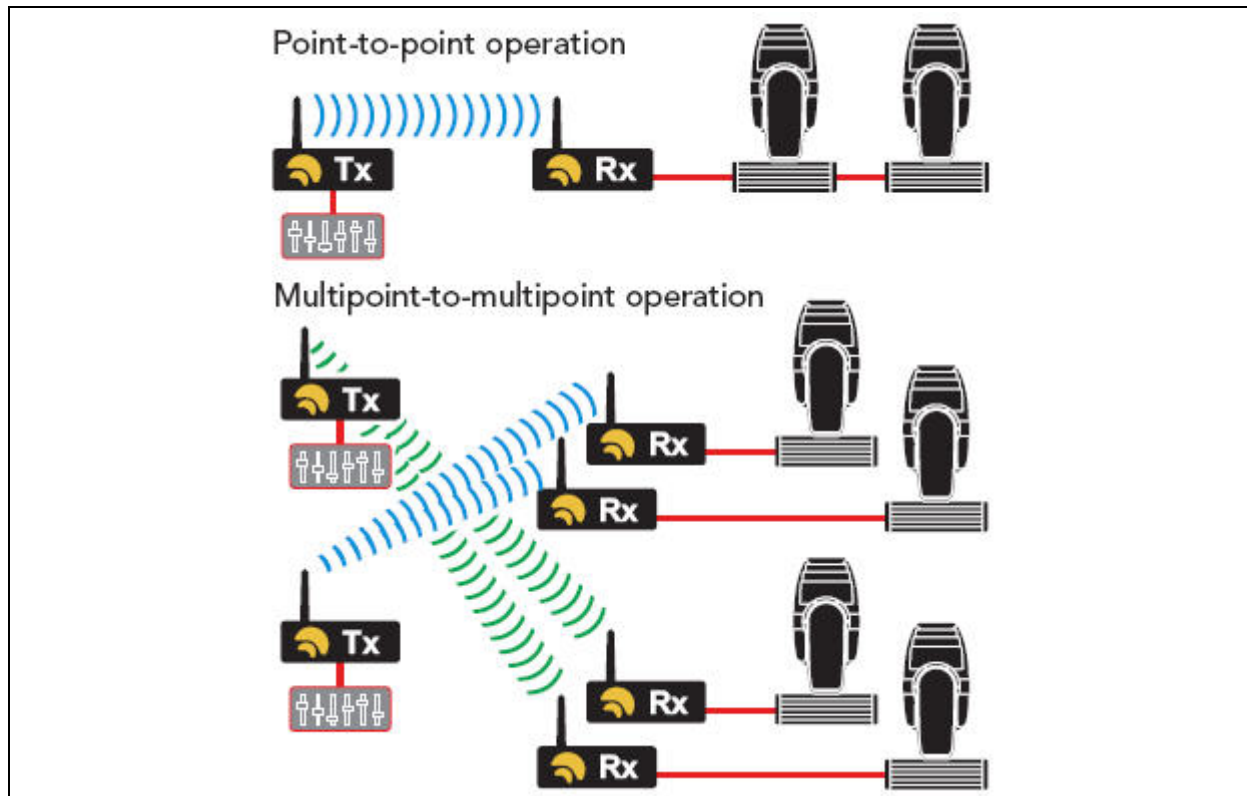

Fig. 1: Point-to-point operation versus multipoint-to-multipoint operation

W-DMX is unique in its use of advanced radio technologies that are also used in mobile phones and military communication.

Rather than using fixed frequency channels, W-DMX uses Adaptive Frequency Hopping technology to continually check the radio channels for interferences and to rapidly move operation to clear radio channels.

The checks are carried out in combination with another advanced technology: time division multiple access. This technology makes the most efficient use of every visited frequency channel.

W-DMX has the following advantages:

- Consistent and wide-ranging control of lighting systems over long distances.

- The complex communication protocols are fully automated and concealed from view - you just plug-and-play, the W-DMX G4 units do all the hard work.
- From the DMX connector of one W-DMX G4 unit to the DMX connector of another, the W-DMX system is totally transparent.

The W-DMX G4 system includes additional features that help to enhance reliability: both in its installation in any type of environment as well as in its stable operation.

W-DMX meets the USITT DMX512 and DMX512-A standards. Furthermore, W-DMX units support Art-Net (I/II), Streaming ACN, ETCNet3, RDM and Pathport protocols (Ethernet and RDM functionality depends on used model). This is why the W-DMX G4 units continually are awarded the first prize for distance covered, resilience against interference and easy installation.

For additional information about our technology, please visit our website at www.wirelessdmx.com.

3 About this document

3 About this document





3.1 Target group of this document

This document is designed for lighting designers, lighting operations managers and lightning technicians.

W-DMX is an easy-to-use plug-and-play system. Basic knowledge of lighting technologies is an advantage. Every user has to be familiar with **local regulations regarding frequencies** and their usage.

For advanced settings and projects, please contact your distributor.

3.2 Signs and symbols in this document

Sign / symbol	Description
 Danger	Indicates notes that, if not observed, will inevitably lead to severe injuries or death.
 Warning	Indicates notes that, if not observed, can lead to severe injuries or death.
 Caution	Indicates notes that, if not observed, can lead to light injuries.
 Hint	Indicates useful information designed to make working with the unit easier.
✓	Indicates a requirement that must be met before you can complete the corresponding tasks.
1. 2.	Indicates tasks you have to complete. The tasks must be completed in the specified order.
➔	Indicates the result of a task or a series of tasks.

4 BlackBox and WhiteBox F-1

BlackBox and WhiteBox are functionally identical. The BlackBox is intended for indoor usage, the WhiteBox for outdoor usage.

4.1 Scope of delivery

4.1.1 BlackBox

- 1 x BlackBox F-1 device
- 1 x User manual
- 1 x Antenna adapter
- 1 x dual band antenna indoor (2 dBi)
- 2 x mounting bracket
- 1 x Phoenix gold connector
- 1 x power cable without plug

4.1.2 WhiteBox

- 1 x WhiteBox F-1 device
- 1 x User manual
- 1 x Outdoor antennae (2 dBi)
- 1 x Phoenix gold connector

4 BlackBox and WhiteBox F-1

4.2 Connectors and ports

4.2.1 BlackBox

⚠ Caution

Damage to the unit!

Connecting more than one DMX universe at a time damages the unit.

- Connect only one DMX universe input at a time.

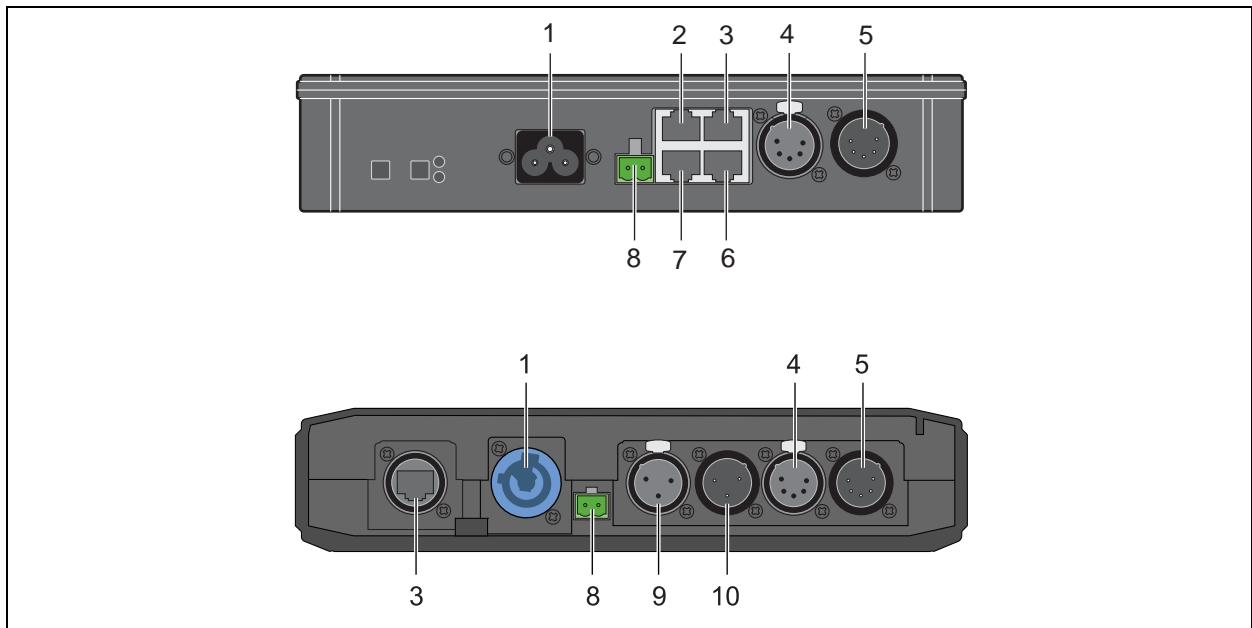

Fig. 2: Connectors and ports of F-1
(Upper picture: MK I; lower picture: MK II)

No.	Port	Description
1	AC power input	90 – 250 V AC
2	Reserved	–
3	Ethernet (optional)	RJ45 port (MK II : EtherCon RJ45 port)
4	DMX OUT bypass	XLR female 5 pin (BlackBox only) universe 1
5	DMX IN	XLR male 5 pin (BlackBox only) universe 1
6	Reserved	–
7	DMX IN / OUT:	RJ45 port (not BlackBox MK II):
		1: Univ 1+ 5: –
		2: Univ 1- 6: –
		3: – 7: Univ 1 GND
		4: – 8: –

No.	Port	Description
8	DC power input	Input for Phoenix Gold Connector: <ul style="list-style-type: none"> • Left: Ground • Right: +12 V DC
9	DMX OUT bypass	XLR female 3 pin (BlackBox MK II only)
10	DMX IN	XLR male 3 pin (BlackBox MK II only)

4.2.2 WhiteBox

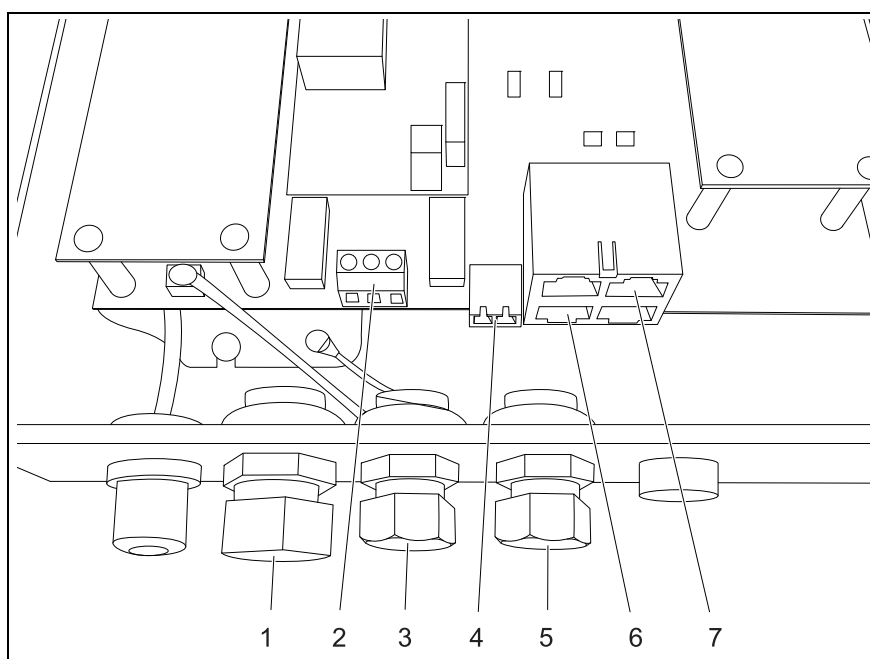

Fig. 3: Connectors and ports of the WhiteBox

On the WhiteBox models there are no XLR connectors to ensure safe transmission of signals for outdoor use. For this reason the connection of DMX signal cables differs slightly from the BlackBox models, which are for indoor use only.

For installation of the unit it is necessary to open the housing. Refer to the chapter “4.4 Installing the unit“ > “4.4.2 WhiteBox“, page 16.

No.	Port	Description
1	Cord Strip	For AC power input (2)
2	AC power input	90 – 250 V AC <ul style="list-style-type: none"> • Left: Outer conductor (L) • Middle: Ground (GND) • Right: Neutral conductor (N)
3	Cord Strip	For DC power input (4)

4 BlackBox and WhiteBox F-1

No.	Port	Description	
4	DC power input	Phoenix Gold Connector 12 V DC <ul style="list-style-type: none"> Left: Ground Right: +12 V DC 	
5	Cord Strip	For signal cable (DMX or Ethernet)	
6	DMX	RJ45 port:	
		1: Univ 1+	5: –
		2: Univ 1–	6: –
		3: –	7: Univ 1 GND
		4: –	8: –
7	Ethernet (optional)	RJ45 port	

4.3 LEDs

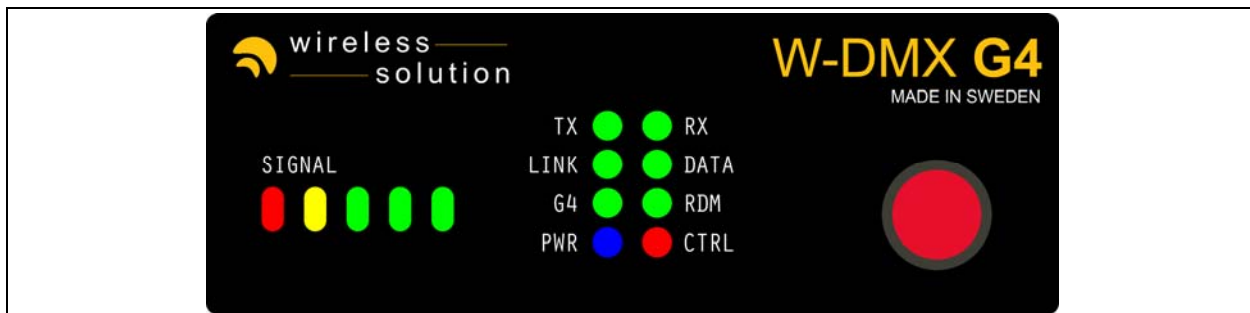

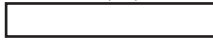



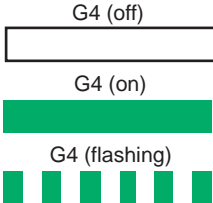
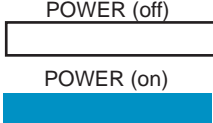

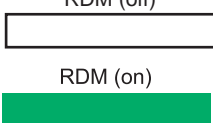
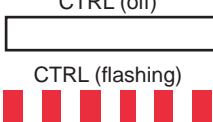

Fig. 4: LEDs of F-1

Name	LED signal	Description
Signal bar	–	Currently received signal strength (in RX (receiver) mode)
TX	TX (on) 	Unit in TX (transmitter) mode
LINK	LINK (off) 	In TX (transmitter) mode: <ul style="list-style-type: none"> On: Normal operation Slow flashing: Receivers are being unlinked Rapid flashing: Receivers are being linked In RX (receiver) mode: <ul style="list-style-type: none"> Off: Unit is not linked to any transmitter On: Unit is linked to transmitter Slow flashing: Transmitters are being searched or linked transmitter is lost. Rapid flashing: Transmitters are being linked
	LINK (on) 	
	LINK (flashing) 	
	LINK (rapid flashing) 	

Name	LED signal	Description
G4	 <p>G4 (off)</p> <p>G4 (on)</p> <p>G4 (flashing)</p>	<ul style="list-style-type: none"> Off: Unit in G3 mode On: Unit in G4 2.4 GHz mode Flashing: Unit in G4 5.8 GHz mode
PWR	 <p>POWER (off)</p> <p>POWER (on)</p>	Power on / off
RX	 <p>RX (on)</p>	Unit in RX (receiver) mode
DATA	 <p>DATA (on)</p>	Data is available at the input / output
RDM	 <p>RDM (off)</p> <p>RDM (on)</p>	WhiteBox: included, BlackBox: optional <ul style="list-style-type: none"> Off: No RDM data is available at the input / output for a minimum of 2 seconds. On: RDM data is available at the input / output
CTRL	 <p>CTRL (off)</p> <p>CTRL (flashing)</p>	<ul style="list-style-type: none"> Off: Normal operation Flashing: CTRL mode to set the frequency band, see chapter "4.8 Switching CTRL modes", page 21

4.4 Installing the unit

4.4.1 BlackBox

- Choose one of the following options to make the DMX connection:
 - Connect the DMX source to the XLR 5 pin DMX IN port (BlackBox only) or the to the RJ 45 DMX IN port.
 - Connect the DMX fixture to the XLR 5 pin DMX OUT port (BlackBox only) or the RJ 45 DMX OUT port.
 - Unit with optional Ethernet lighting protocol support:
Connect the Ethernet lighting source or output to the Ethernet in port.
- Attach the supplied standard antenna(s) and standard adapter(s) or other suitable antenna(s) / adapter(s) available from Wireless Solution to the matching connector(s).

4 BlackBox and WhiteBox F-1

Warning

Risk of death by electrocution!

AC power connection must be carried out correctly.

- Make sure that only a qualified, trained electrician carries out AC power connection.
- Make sure the correct Schuko connector or other connector suitable for your country is used.

3. Choose one of the following options to connect power to the unit:
 - Attach a suitable mains plug to the supplied power cord and connect the power supply to the AC power input.
 - Connect the power supply to the DC power input.
4. If required, attach the unit to the supplied mounting brackets or other mounting hardware available from Wireless Solution.

4.4.2 WhiteBox

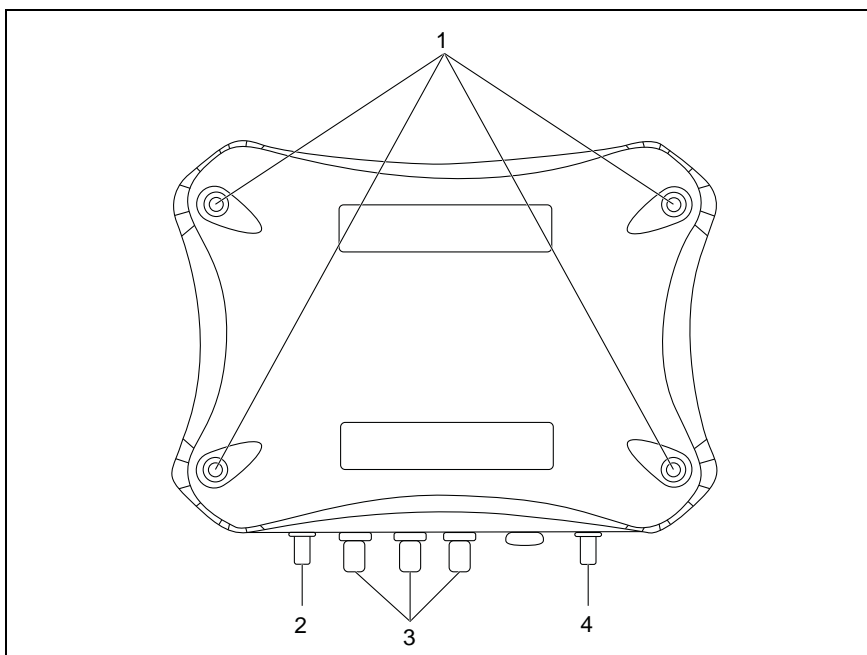

Fig. 5: Housing of the WhiteBox models

When connecting a WhiteBox model it is necessary to open the housing.

⚠ Warning**Risk of death by electrocution!**

AC power connection must be carried out correctly.

- Make sure that only a qualified, trained electrician carries out AC power connection.
- Make sure the correct Schuko connector or other connector suitable for your country is used.

1. Unscrew the housing by the 4 screws (1).
2. Open the housing.

Caution**Damage to the unit!**

- Make sure no contact voltage is transferred when touching the connection cables.

3. Loosen the cord strips (3) by turning the screws counter-clockwise.
4. Put the cables through the cord strips (3).
5. When using AC, put the AC power cables into the socket (see chapter “4.2.2 WhiteBox“, page 13) and tight the bolts of the socket.
6. Couple the connectors to the cables:
 - When using 12 V DC power, couple the 12 V DC power cable to the Phoenix Gold connector
 - Couple RJ 45 connector to DMX signal cable (or Ethernet cable if option is installed and should be used).
7. Fit the connectors within the sockets (see chapter “4.2.2 WhiteBox“, page 13).
8. Fit the cord strips by turning them clockwise.
9. Close the housing and fit the 4 screws (1) by turning them clockwise.

4.5 Switching FLEX modes

The FLEX mode determines if the unit is used in Transmit Mode (TX) or Receive Mode (RX).

To switch the FLEX mode, proceed as follows:

1. Disconnect the power cable.

4 BlackBox and WhiteBox F-1



2. Press and hold the function button on the front panel (1).
 3. Reconnect the power cable.
 4. Release the function button.
- ➔ The mode is switched. The LEDs indicate the current mode: either TX (1) or RX (2):

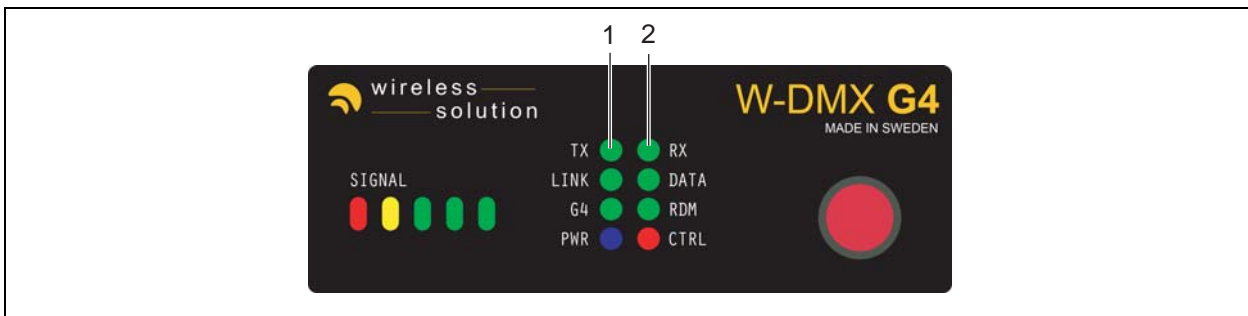

4.6 Operation as a transmitter

- ✓ The unit is in Transmit Mode (TX), working as a transmitter.

4.6.1 Prerequisites for successful linking with receivers

Hint

The figures are maximum figures and depend on output levels. Local settings may be required. For advanced settings and projects, contact your distributor.

For successful linking, the receiver must fulfill the following conditions:

- ✓ Distance to transmitter (air): up to 200 m (Micro units)
- ✓ Distance to transmitter (air): up to 500 m (BlackBox, WhiteBox and ProBox in ETSI mode)

- ✓ Distance to transmitter (air): up to 750 m (BlackBox, WhiteBox and ProBox in FCC mode)

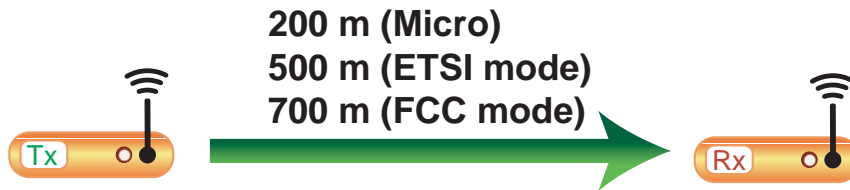

- ✓ Distance to transmitter (glass): up to 500 m

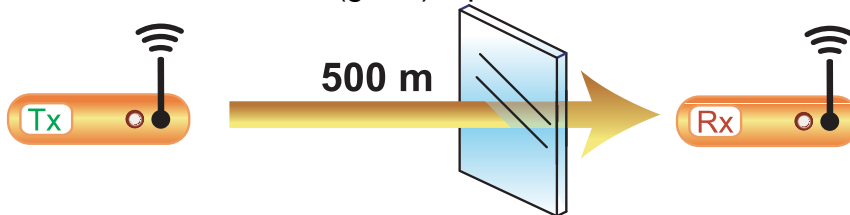

- ✓ Distance to transmitter (wall, except concrete): up to 350 m

- ✓ Distance to transmitter (concrete): up to 150 m

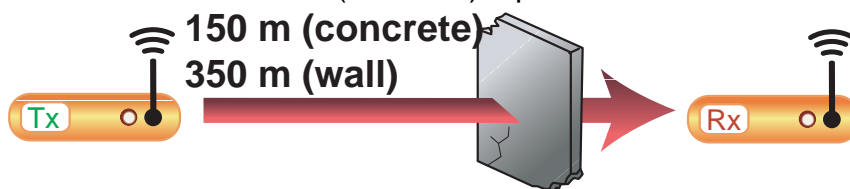

- ✓ Position above crowds: min. 1 m

- ✓ Position above trees: min. 1 m

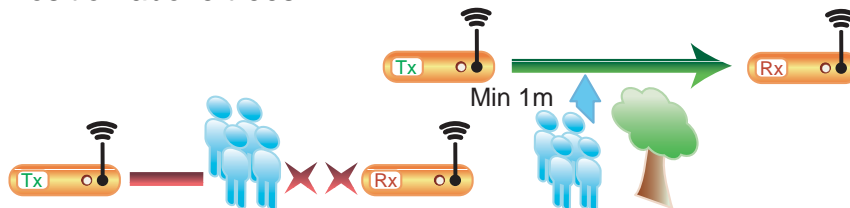

4.6.2 Linking receivers

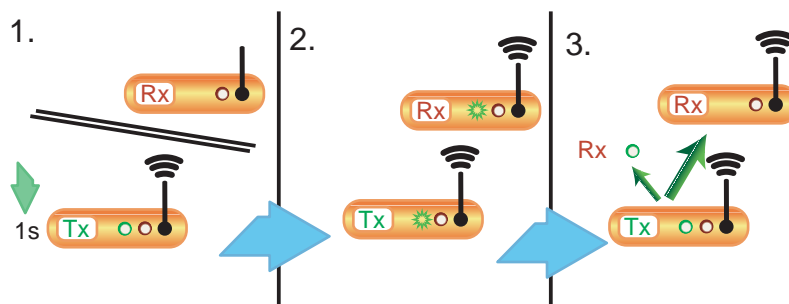

Hint

You can link receivers at any time, also during operation.

1. Power on the receivers you want to link.

4 BlackBox and WhiteBox F-1

2. Ensure that the receiver is not connected to any other transmitter, i.e., the LINK LED on the receiver is off.

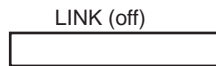

3. Press the function button of the transmitter for 1 second.

- ➔ The transmitter scans for all unlinked receivers for a period of about 10 seconds. The LINK LED flashes rapidly.



- ➔ If the connection is successful, the LINK LED on the receiver goes on. If DMX input is available, the DATA LED goes on as well.

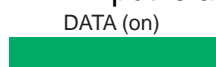

- ➔ If the connection fails, check the position of the receiver, see chapter "4.6.1 Prerequisites for successful linking", page 18.

- ➔ The signal bar on the receiver indicates the received signal strength.

4.6.3 Unlinking all receivers

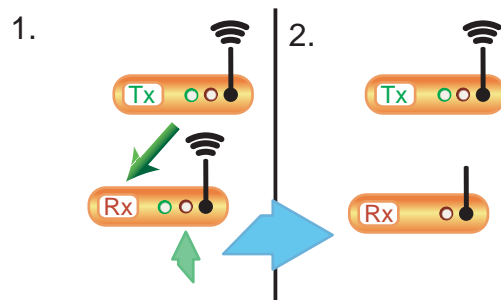

Use this procedure to unlink all receivers connected with the unit.

1. Press the function button on the transmitter for 3 seconds, until the LINK LED flashes slowly.

- ➔ The LINK LED flashes slowly.



- ➔ The signal bars of the receivers fall back to zero.

- ➔ All connected receivers are unlinked.

Hint

To unlink one specific receiver, press and hold the function button on the specific receiver for 3 seconds.

4.7 Operation as a receiver

- ✓ The unit is in Receive Mode (RX), working as a receiver.

4.7.1 Linking with transmitters

 **Hint**

During the link procedure the DMX transmission is interrupted.

1. Power on the receiver.
2. Ensure that the receiver is not connected to any other transmitter, i.e., the LINK LED on the receiver is off.

LINK (off)

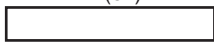

3. Press the function button of the transmitter for 1 second.

- ➔ The transmitter scans for all unlinked receivers for a period of about 10 seconds. The LINK LED flashes rapidly.

LINK (rapid flashing)



- ➔ If the connection is successful, the LINK LED on the receiver goes on. If DMX input is available, the DATA LED goes on as well.

DATA (on)



- ➔ If the connection fails, check the position of the receiver, see chapter "4.6.1 Prerequisites for successful linking", page 18.

- ➔ The signal bar on the receiver indicates the received signal strength.

4.7.2 Unlinking from transmitters

1. Press the function button on the receiver until the LINK LED goes out.

LINK (off)

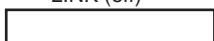

- ➔ The receiver is unlinked.

4.8 Switching CTRL modes

The CTRL mode determines which frequency band is used and if Legacy G2 and G3 units can be used in the wireless environment.

Wireless DMX G4 units in Transmit Mode (TX) can switch the CTRL mode of the entire system:

- G3 2.4 GHz mode (Legacy G2 and G3 units)
- G4 2.4 GHz mode
- G4 5.8 GHz mode

4 BlackBox and WhiteBox F-1

All G4 receivers automatically detect the mode the transmitter is in and adapt to it.

To change the CTRL mode, proceed as follows:

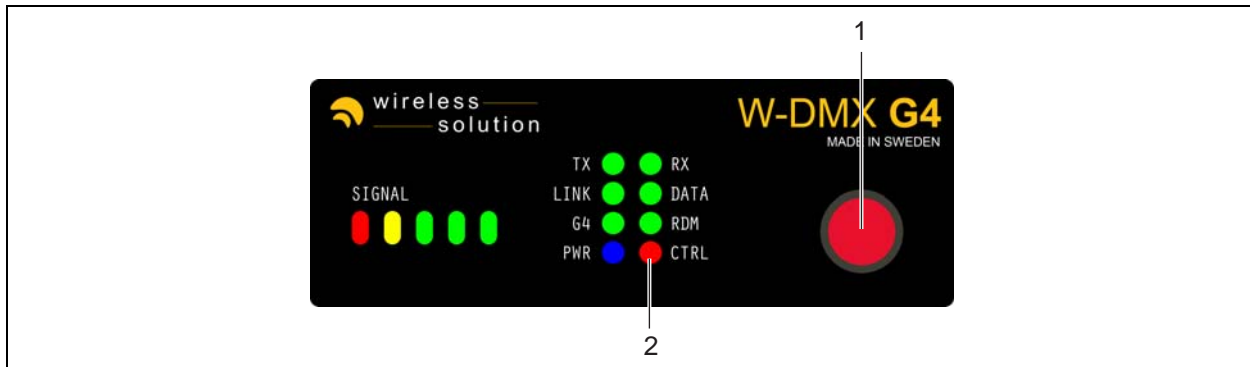

- ✓ The unit is in Transmit Mode (TX), working as a transmitter.



1. Press and hold the function button on the front panel (1) for at least 10 seconds.

Hint

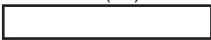
Keep holding the button even if the LINK LED starts blinking. This allows you to go through the unlink mode without unlinking.

- ➔ The CTRL LED (2) flashes. The unit is in CTRL mode.
2. Release the function button.
 3. Press the function button repeatedly until the desired mode is displayed via the status of the G4 LED:
 - G3 2.4 GHz mode: G4 LED is off
G4 (off)

 - G4 2.4 GHz mode: G4 LED is on
G4 (on)

 - G4 5.8 GHz mode: G4 LED flashes
G4 (flashing)

 - ➔ The desired mode is set.
 4. Power-cycle the unit to leave control mode and restart operation.

5 BlackBox and WhiteBox R-512

BlackBox and WhiteBox are functionally identical. The BlackBox is intended for indoor usage, the WhiteBox for outdoor usage.

5.1 Scope of delivery

5.1.1 BlackBox

- 1 x BlackBox R-512 device
- 1 x User manual
- 1 x Antenna adapter
- 1 x dual band antenna indoor (2 dBi)
- 2 x mounting bracket
- 1 x Phoenix gold connector
- 1 x power cable without plug (not MK II)

5.1.2 WhiteBox

- 1 x WhiteBox R-512 device
- 1 x User manual
- 1 x Outdoor antenna (2 dBi)
- 1 x Phoenix gold connector

5.2 Connectors and ports

5.2.1 BlackBox

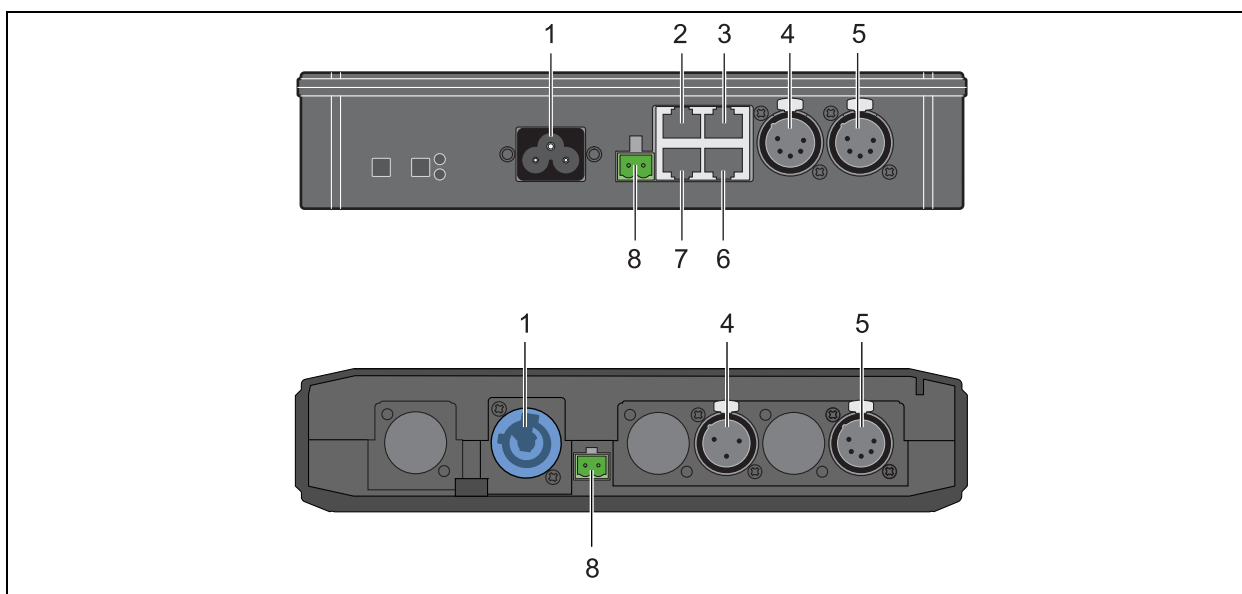

Fig. 6: Connectors and ports of R-512
(Upper picture: MK I; lower picture: MK II)

5 BlackBox and WhiteBox R-512

No.	Port	Description
1	AC power input	90 – 250 V AC MK II: PowerCon connector
2	Reserved	–
3	Reserved	–
4	DMX OUT	<ul style="list-style-type: none"> • MK I: XLR female 5 pin • MK II: XLR female 3 pin
5	DMX OUT	XLR female 5 pin
6	Reserved	–
7	DMX OUT	RJ 45 port: 1: Univ 1+ 5: – 2: Univ 1– 6: – 3: – 7: Univ 1 GND 4: – 8: –
8	DC power input	Input for Phoenix Gold Connector: <ul style="list-style-type: none"> • Left: Ground • Right: +12 V DC

5.2.2 WhiteBox

Connectors and ports of the WhiteBox R-512 are identical to the WhiteBox F-1, see chapter "4.2.2 WhiteBox", page 13.

5.3 LEDs

LED signals are identical to F-1 (see chapter "4.3 LEDs", page 14).

 Notes
The R-512 does not have transmission functionality. The R-512 does not provide CTRL mode, because the receiver detects the right mode automatically.

5.4 Installing the unit

Installation is identical to:

- BlackBox F-1: see chapter "4.4.1 BlackBox", page 15
- WhiteBox F-1: see chapter "4.4.2 WhiteBox", page 16

5.5 Operation as a receiver

Operation as a receiver is identical to the BlackBox and WhiteBox F-1, see chapter "4.7 Operation as a receiver", page 21.

6 BlackBox and WhiteBox F-2

BlackBox and WhiteBox are functionally identical. The BlackBox is intended for indoor usage, the WhiteBox for outdoor usage.

6.1 Scope of delivery

6.1.1 BlackBox

- 1 x BlackBox F-2 device
- 1 x User manual
- 2 x Antennae adapter
- 2 x dual band antennae indoor (2 dBi)
- 2 x mounting bracket
- 1 x Phoenix gold connector
- 1 x power cable without plug (not MK II)

6.1.2 WhiteBox

- 1 x WhiteBox F-2 device
- 1 x User manual
- 2 x Outdoor antenna (2 dBi)
- 1 x Phoenix gold connector

6.2 Connectors and ports

6.2.1 BlackBox

Caution
Damage to the unit! Connecting more than one DMX universe to each pair of universe connectors (XLR / RJ45) at a time damages the unit. <ul style="list-style-type: none">• Connect only one DMX universe input to each pair of universe connectors (XLR / RJ45) at a time.

6 BlackBox and WhiteBox F-2

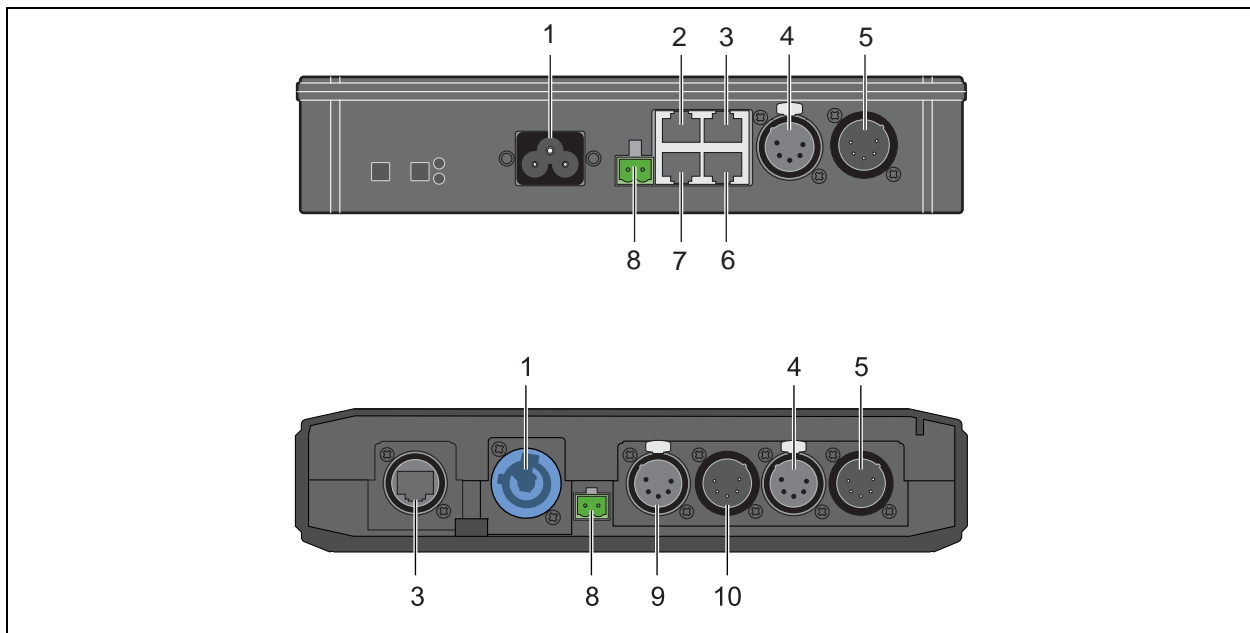

Fig. 7: Connectors and ports of the BlackBox F-2
(Upper picture: MK I; lower picture: MK II)

Hint

On BlackBox F-2 MK I, the universe 2 output is only available via RJ 45 ports.

No.	Port	Description
1	AC power input	90 – 250 V AC MK II: PowerCon 20A
2	Reserved	–
3	Ethernet	RJ 45 port
4	DMX OUT / bypass	XLR female 5 pin output (BlackBox only) for Univ 1
5	DMX IN	XLR male 5 pin input (BlackBox only) for Univ 1
6	DMX IN / OUT standard for Univ 2	RJ 45 port (not BlackBox MK II): 1: Univ 2+ 5: – 2: Univ 2– 6: Univ 1– 3: Univ 1+ 7: Univ 2 GND 4: – 8: Univ 1 GND
7	DMX IN / OUT standard for Univ 1	RJ 45 port: 1: Univ 1+ 5: – 2: Univ 1– 6: Univ 2– 3: Univ 2+ 7: Univ 1 GND 4: – 8: Univ 2 GND

No.	Port	Description
8	DC power input	Input for Phoenix Gold Connector: <ul style="list-style-type: none"> • Left: Ground • Right: +12 V DC
9	DMX OUT / bypass	XLR female 5 pin output (BlackBox MK II only) for Univ 2
10	DMX IN	XLR male 5 pin input (BlackBox MK II only) for Univ 2

6.2.2 WhiteBox

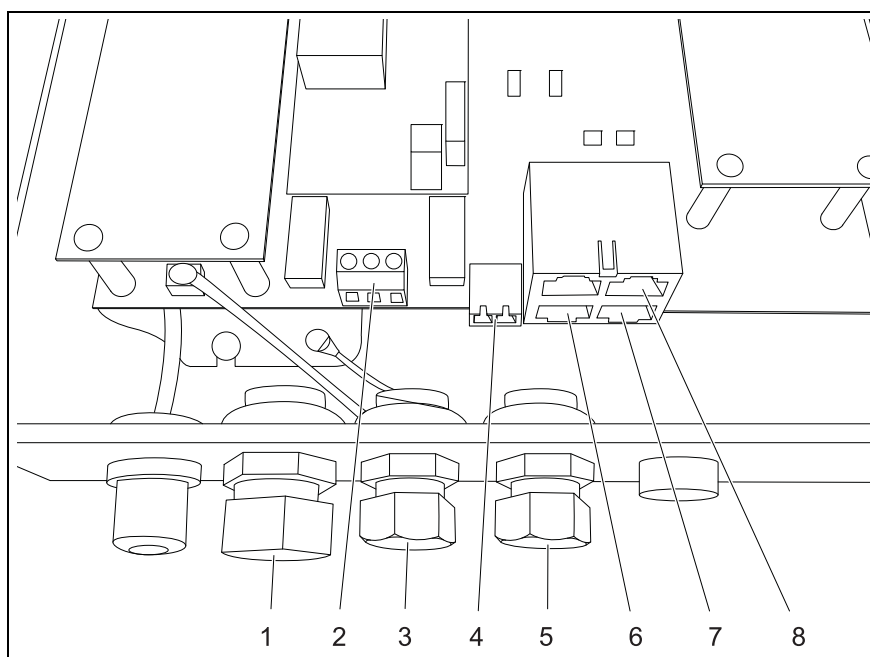

Fig. 8: Connectors and ports of the WhiteBox

On the WhiteBox models there are no XLR connectors to ensure safe transmission of signals for outdoor use. For this reason the connection to DMX signal cables differs slightly to the BlackBox models, which are for indoor use only.

No.	Port	Description
1	Cord Strip	For AC power input (2)
2	AC power input	90 – 250 V AC <ul style="list-style-type: none"> • Left: Outer conductor (L) • Middle: Ground (GND) • Right: Neutral conductor (N)
3	Cord Strip	For DC power input (4)
4	DC power input	Phoenix Gold Connector 12 V DC <ul style="list-style-type: none"> • Left: Ground • Right: +12 V DC
5	Cord Strip	For signal cable (DMX or Ethernet)

6 BlackBox and WhiteBox F-2

No.	Port	Description	
6	DMX IN/OUT standard for Univ 1	RJ45 port:	
		1: Univ 1+	5: –
		2: Univ 1–	6: Univ 2–
		3: Univ 2+	7: Univ 1 GND
		4: –	8: Univ 2 GND
7	DMX IN/OUT standard for Univ 2	RJ45 port:	
		1: Univ 2+	5: –
		2: Univ 2–	6: Univ 1–
		3: Univ 1+	7: Univ 2 GND
		4: –	8: Univ 1 GND
8	Ethernet (optional)	RJ45 port	

6.3 LEDs

The F-2 units are equipped with two identical sets of LEDs and function keys:

- Left: Universe 1
- Right: Universe 2

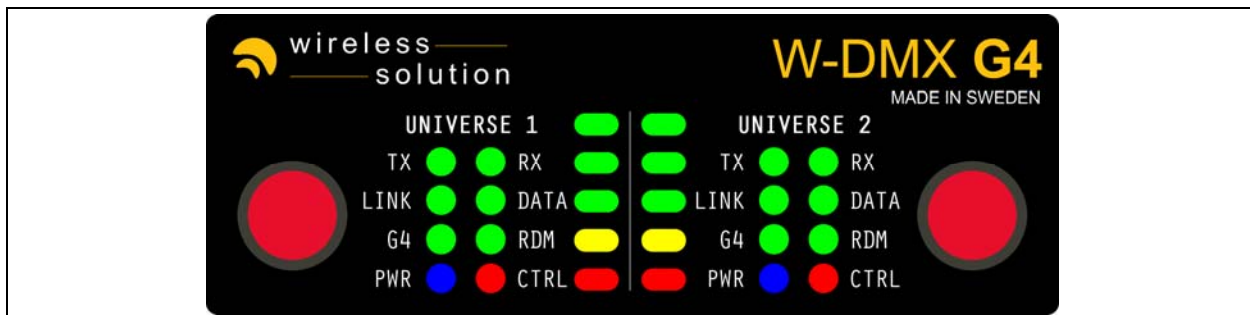

Fig. 9: LEDs of F-2

For the description of the LED meanings, please refer to “4.3 LEDs“, page 14.

6.4 Installing the unit

Installation is identical to:

- BlackBox F-2: see chapter “4.4.1 BlackBox“, page 15.
- WhiteBox F-2: see chapter “4.4.2 WhiteBox“, page 16.

Notes

- You have to install two antennas.
- On BlackBox MK I, Universe 2 is only available via RJ45 port.

6.5 Switching FLEX modes

The FLEX mode determines if the unit is used in Transmit Mode (TX) or Receive Mode (RX).

To switch the FLEX mode, proceed as follows:

1. Disconnect the power cable.

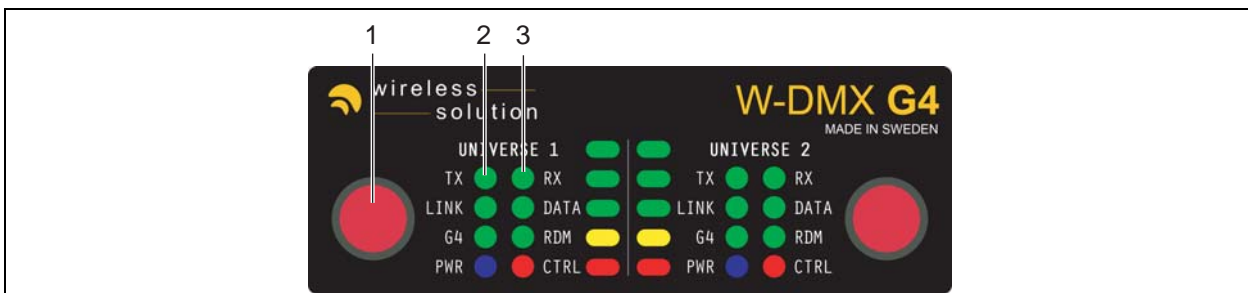

2. Press and hold the left function button (Universe 1) on the front panel (1).
 3. If necessary, repeat step 2 for Universe 2 on the right side of the front panel. Functional elements are identical to the left side (Universe 1).
 4. Reconnect the power cable.
 5. Release the function button.
- ➔ The FLEX mode is switched. The LEDs indicate the current mode: either TX (2) or RX (3).

6 BlackBox and WhiteBox F-2

6.6 Operation as a transmitter

Operation as a transmitter is identical to the BlackBox and WhiteBox F-1, see chapter "4.6 Operation as a transmitter", page 18.

Carry out the procedures for each universe individually.

Hint

When you link the receivers for Universe 1, power-on only the respective receivers for Universe 1.

Once the receivers for Universe 1 are connected, you can power-on the receivers for Universe 2 and link them.

6.7 Operation as a receiver

Operation as a receiver is identical to the BlackBox and WhiteBox F-1, see chapter "4.7 Operation as a receiver", page 21.

Carry out the procedures for each universe individually.

6.8 Switching CTRL modes

The CTRL mode determines which frequency band is used in G4 mode and if Legacy G2/G3 units can be used in the wireless environment.

Switching CTRL mode is identical to the BlackBox and WhiteBox F-1, see chapter "4.8 Switching CTRL modes", page 21.

Note

The F-2 unit provides 2 universes.

- Carry out the procedures for each universe individually.

7 Micro units

7.1 Micro F-1 Lite

7.1.1 Scope of delivery

- 1 x Micro F-1 Lite
- 1 x User manual
- 1 x External power supply unit
- Adapters for several electrical outlets
- 1 x Hook-and-loop belt

7.1.2 Connectors and ports

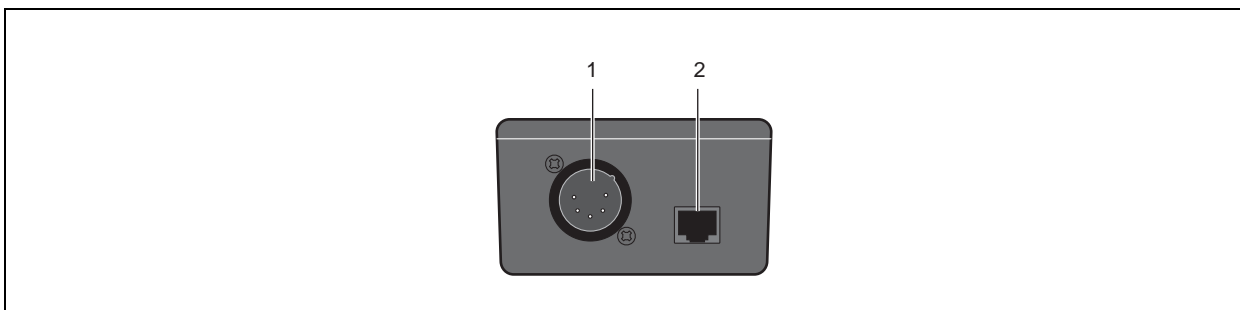

Fig. 10: Micro F-1 Lite, side view

No.	Port	Description
1	DMX IN	XLR male 5 pin. If you want to use the unit as a receiver, you can buy an optional XLR 5-pin female-to-female adapter.
2	DC power input	RJ45 port: +12 V DC (Connector for EMS120050-P19-SZ)

7 Micro units

7.1.3 LEDs

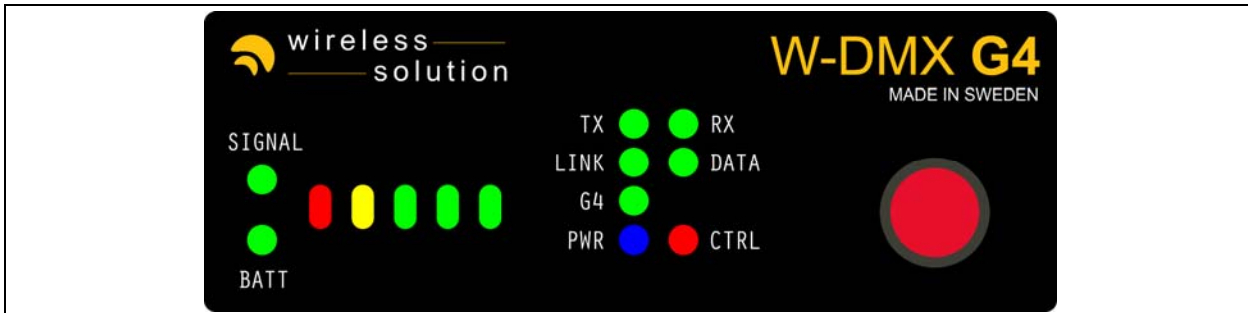

Fig. 11: LEDs of Micro F-1 Lite

SIGNAL/BATT: Identifies if the signal strength or battery power is displayed on the LED bar.

Other LED signals are identical to F-1 (see chapter “4.3 LEDs“, page 14).

Note

Micro F-1 Lite does not have the G4 5.8 GHz mode.

7.1.4 Installing the unit

1. Choose one of the following options to make the DMX connection:
 - Connect the DMX source to the DMX IN / OUT port.
 - Connect the DMX fixture to the DMX IN / OUT port.
2. Connect the power supply to the DC power input.

7.1.5 Switching FLEX modes

The FLEX mode determines if the unit is used in Transmit Mode (TX) or Receive Mode (RX). Switching the FLEX mode is identical to the BlackBox F-1, see “4.5 Switching FLEX modes“, page 17.

7.1.6 Operation as a transmitter

Operation as a transmitter is identical to the BlackBox and WhiteBox F-1, see chapter "4.6 Operation as a transmitter", page 18.

7.1.7 Operation as a receiver

Operation as a receiver is identical to the BlackBox and WhiteBox F-1, see chapter "4.7 Operation as a receiver", page 21.

7.1.8 Switching CTRL modes

The CTRL mode determines which frequency band is used and if Legacy G2/G3 units can be used in the wireless environment.

Switching CTRL mode is identical to the BlackBox and WhiteBox F-1, see chapter "4.8 Switching CTRL modes", page 21.

 **Hint**

This unit does not support the G4 5.8 GHz mode.

7.1.9 Battery option

The W-DMX G4 Micro units are equipped with a holder for 6 AAA batteries. If batteries are installed in the unit and 12 V DC power is disconnected, the unit runs on battery power. The BATT and SIGNAL LED light up alternately every 5 seconds:

- When the BATT LED is on, the signal bars indicate battery status.
- When the SIGNAL LED is on, the signal bars indicate signal strength.

On average, the W-DMX receiver can receive for approximately from 4 to 8 hours in battery mode. The exact battery life depends on the brand of batteries and mode of the W-DMX unit.

 **Hint**

We recommend testing the discharge time of your selected batteries before using them in a show environment.

The W-DMX G4 Micro units are compatible with rechargeable batteries (down to 1.2 V DC per cell). Note, that the batteries cannot be charged with the Micro units. Please use an appropriate battery charger.

7 Micro units

7.2 Micro R-512 Lite

The unit is provided with a battery option, see chapter "7.1.9 Battery option", page 33.

7.2.1 Scope of delivery

- 1 x Micro R-512 Lite device
- 1 x User manual
- 1 x External power supply unit
- Adapters for several electrical outlets
- 1 x Hook-and-loop belt

7.2.2 Connectors and ports

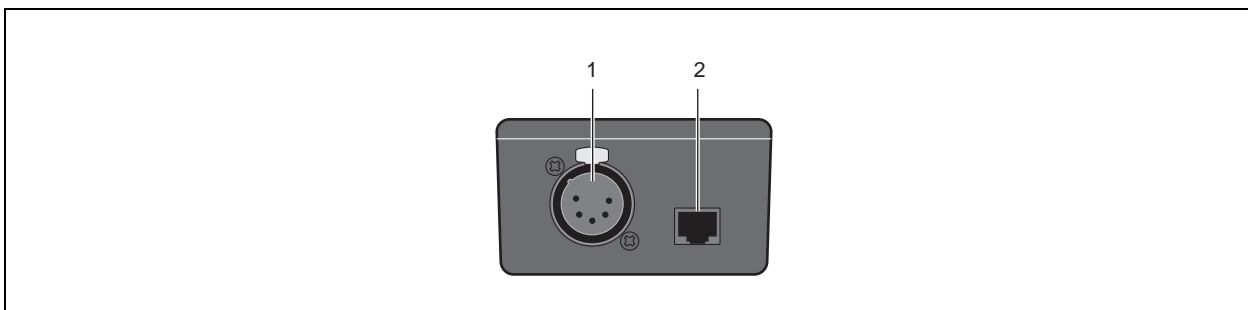

Fig. 12: Micro R-512 Lite, side view

No.	Port	Description
1	DMX OUT	XLR female 5 pin
2	DC power input	RJ45 port: +12 V DC (Connector EMS120050-P19-SZ)

7.2.3 LEDs

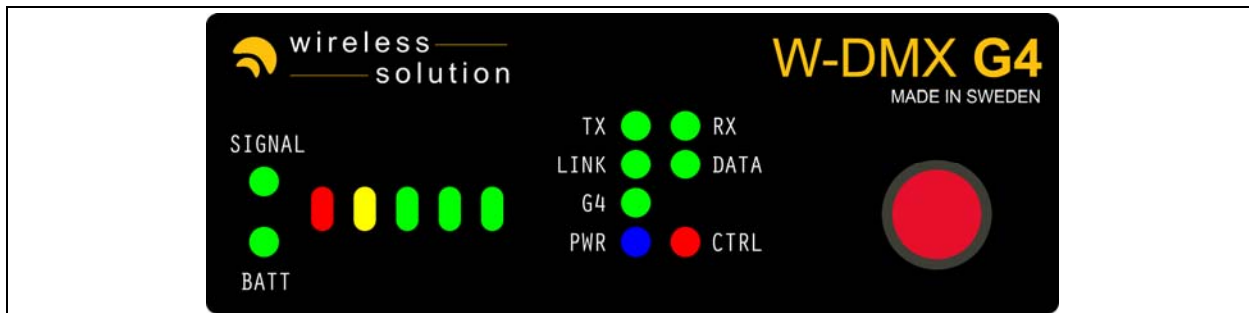

Fig. 13: LEDs of Micro R-512 Lite

SIGNAL/BATT: Identifies if the signal strength or battery power is displayed on the LED bar.

Other LED signals are identical to F-1, see chapter "4.3 LEDs", page 14.

Note

- Micro R-512 Lite does not have the G4 5.8 GHz mode.
- Micro R-512 Lite does not have a transmission function, LED "TX" is never used.
- Micro R-512 Lite does not have RDM support.

7.2.4 Installing the unit

Installation is identical to the Micro F-1 Lite, see chapter "7.1.4 Installing the unit", page 32.

7.2.5 Operation as a receiver

Operation as a receiver is identical to the BlackBox and WhiteBox F-1, see chapter "4.7 Operation as a receiver", page 21.

7.2.6 Switching CTRL modes

The CTRL mode determines which frequency band is used and if Legacy G2/G3 units can be used in the wireless environment.

Switching CTRL mode is identical to the BlackBox and WhiteBox F-1, see chapter "4.8 Switching CTRL modes", page 21.

Hint

This unit does not

- support G4 5.8 GHz mode,
- support RDM,
- have CTRL mode (receivers detect the right mode automatically).

8 ProBox F-2500

8.1 Scope of delivery

- 1 x ProBox F-2500 device
- 1 x User manual
- 2 x Antennae adapter
- 2 x dual band antennae indoor (2 dBi)
- 1 x Phoenix gold connector
- 1 x power cable without plug

8.2 Connectors and ports

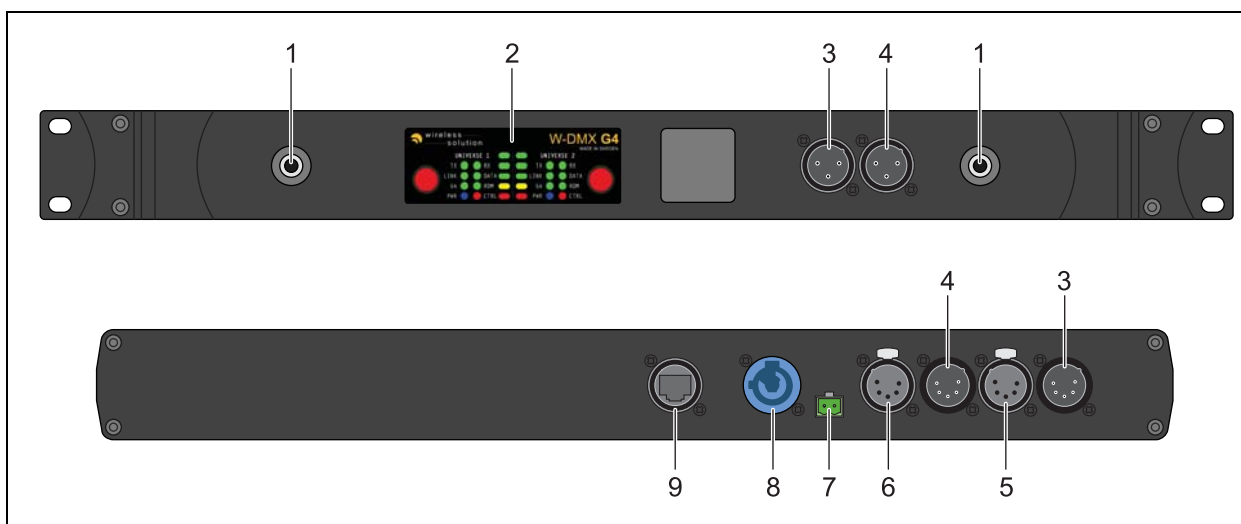

Fig. 14: Connectors and ports of ProBox F-2500
(Upper picture: front panel; lower picture: connector rear)

No.	Port	Description
1	Antennae Ports	Connector for antennas Universe 1: left, Universe 2: right
2	Display & Buttons	See chapter 6.3, page 28
3	DMX IN Universe 1	<ul style="list-style-type: none"> • Front: XLR male 3 pin • Back: XLR male 5 pin
4	DMX IN Universe 2	<ul style="list-style-type: none"> • Front: XLR male 3 pin • Back: XLR male 5 pin
5	DMX OUT Universe 1	XLR female 5 pin
6	DMX OUT Universe 2	XLR female 5 pin
7	DC power input	Input for Phoenix Gold Connector: <ul style="list-style-type: none"> • Left: Ground • Right: +12 V DC

No.	Port	Description
8	AC power input	PowerCon 20A connector
9	Ethernet	EtherCon RJ45 port Supports Power over Ethernet 802.3af

8.3 LEDs

The ProBox F-2500 is equipped with two identical sets of LEDs and function keys:

- Left: Universe 1
- Right: Universe 2

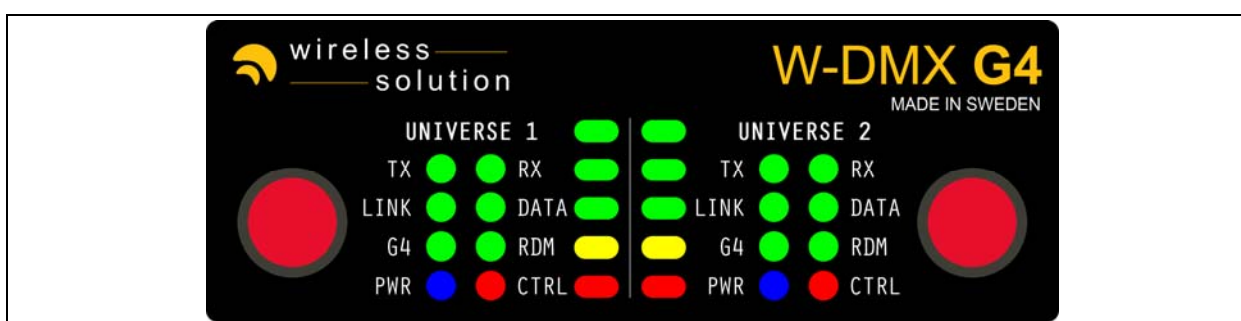

Fig. 15: LEDs of ProBox F-2500

For the description of the LED meanings, please refer to “4.3 LEDs”, page 14.,

8.4 Installing the unit

Installation is identical to the BlackBox F-1, see chapter “4.4.1 BlackBox”, page 15.

8.5 Switching FLEX modes

The FLEX mode determines if the unit is used in Transmit Mode (TX) or Receive Mode (RX). Switching FLEX mode is identical to the BlackBox and WhiteBox F-2, see chapter “6.5 Switching FLEX modes”, page 29.

8.6 Operation as a transmitter

Operation as a transmitter is identical to the BlackBox and WhiteBox F-1, see chapter “4.6 Operation as a transmitter”, page 18.

Carry out the procedures for each universe individually.

 **Hint**

When you link the receivers for Universe 1, power-on only the respective receivers for Universe 1.

Once the receivers for Universe 1 are connected, you can power-on the receivers for Universe 2 and link them.

8.7 Operation as a receiver

Operation as a receiver is identical to the BlackBox and WhiteBox F-1, see chapter "4.7 Operation as a receiver", page 21.

8.8 Switching CTRL modes

The CTRL mode determines which frequency band is used in G4 mode and if Legacy G2/G3 units can be used in the wireless environment.

Switching CTRL mode is identical to the BlackBox and WhiteBox F-1, see chapter "4.8 Switching CTRL modes", page 21.

 **Note**

The ProBox F-2500 provides 2 universes.

- Carry out the procedures for each universe individually.

9 Technical data

9.1 BlackBoxes (BB) and WhiteBoxes (WB) F-1, R-512 and F-2

BlackBox (in mm):

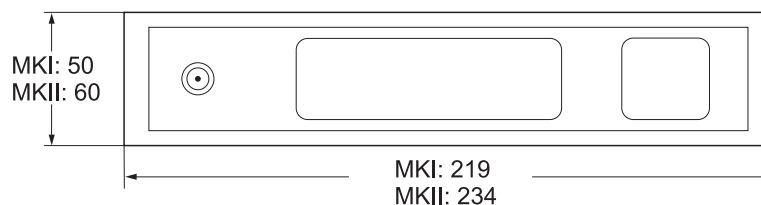

WhiteBox (in mm):

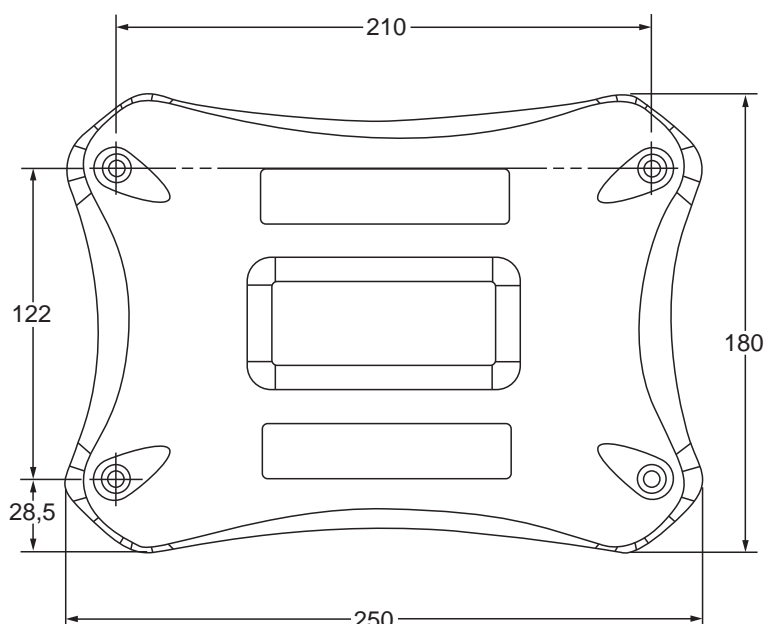

		BB F-1	WB F-1	BB R-512	WB R-512	BB F-2	WB F-2
Electrical data							
Regulations complied with		Certified Worldwide (FCC, ETL, ETSI, CE, Japan, China , Russia)					
High voltage input		90 – 250 V _{AC}					
Low voltage input		12 V _{DC}					
Average current (TX mode)		450 – 700 mA / 12 V _{DC}					
Average current (RX mode)		200 mA / 12 V _{DC}					
DC power supply		Phoenix Gold Connector					
Dimensions							
Width x height x depth	MKI	219 x 131 x 50 mm	250 x 180 x 67.5 mm	219 x 131 x 50 mm	250 x 180 x 67.5 mm	219 x 131 x 50 mm	250 x 180 x 67.5 mm
	MKII	234 x 150 x 60 mm	–	234 x 150 x 60 mm	–	234 x 150 x 60 mm	–
Weight		1005 g	1200 g	1005 g	1200 g	1005 g	1200 g

9 Technical data

	BB F-1	WB F-1	BB R-512	WB R-512	BB F-2	WB F-2
Environmental conditions						
Ambient temperature range (standard)	0°C to 45°C				0°C to 40°C	
Ambient Temperature range (12 V _{DC})	0°C to 55°C					
Humidity	90%					
Input protocols						
DMX512	Yes					
RDM (1)	Yes		Optional		Yes	
Ethernet	Optional		No		Optional	
Streaming ACN	Optional		No		Optional	
Art-Net / Art-Net 2	Optional		No		Optional	
	BB F-1	WB F-1	BB R-512	WB R-512	BB F-2	WB F-2
Radio performance						
Loss of date behavior	As wire					
Output protocols						
DMX512	Yes					
RDM (1)	Yes		Optional		Yes	
Streaming ACN	Optional		No		Optional	
Art-Net	Optional		No		Optional	
Radio technologies						
G3/G4 2.4 GHz	Yes					
G4 5.8 GHz	Yes					
Adaptive Frequency Hopping	Yes					
W-DMX G3 compatibility	Yes					
License free	Yes					
W-DMX Datasafe Redundancy	Yes					
External antenna	Yes					
Standard range	Up to 750 m (standard antenna)					
Expandable range	Unlimited (optional antennas)					
Latency	< 5 ms					
Sensitivity (0.1% PER)	-97 dBm					
Modulation method	GFSK					
Max. power 2.4 GHz EIRP (2)	450 mW					
Max. power 5.8 GHz EIRP (2)	600 mW					
DMX capabilities						
Max. number of universes	32				64	
Input / output Opto Isolation	Yes		No		Yes	
Fully compliant USITT DMX512A	Yes					
W-DMX Invisi-wire	Yes					
Product functionality						
Front panel control	Yes					
W-DMX Uglybox compatible	Yes					
W-DMX Dongle compatible	Yes					
Free software updates	Yes					
Update over air	Yes					
Update over Dongle	Yes					
PC configurable	Yes					
Configurable over RDM	Yes		Optional		Yes	

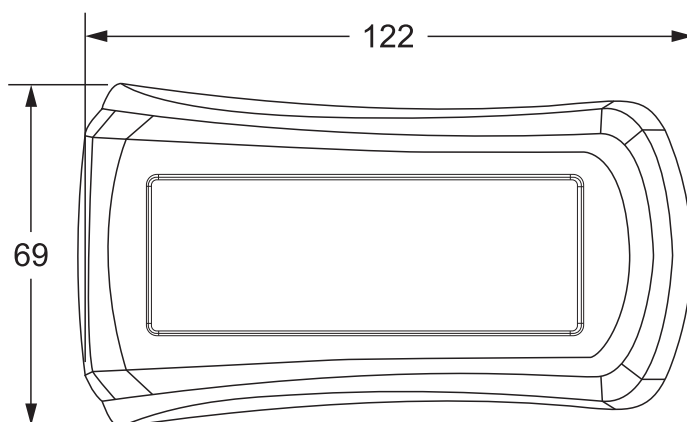
9.2 MicroBox F-1 Lite and MicroBox R-512 Lite

	MicroBox F-1 Lite	MicroBox R-512 Lite
Electrical data		
Regulations complied with	Certified Worldwide (FCC, ETL, ETSI, CE, Japan, China , Russia)	
High voltage input	90 to 250 V _{AC} (external power supply)	
Low voltage input	12 V _{DC}	
Average current (TX mode)	450 to 700 mA / 12 V _{DC}	
Average current (RX mode)	200 mA / 12 V _{DC}	
DC power supply	Connector EMS120050-P19-SZ	
Dimensions		
Width x height x depth	122 x 69 x 43 mm	
Weight (without battery)	130 g	
Environmental conditions		
Ambient temperature range (standard)	0°C to 55°C	
Ambient temperature range (12 V _{DC})	0°C to 55°C	
Humidity	90%	
Input protocols		
DMX512	Yes	
RDM (1)	Yes	No
Ethernet	No	
Streaming ACN (incl. ETCNet3)	No	
Art-Net	No	
Pathport	No	
Strand ShowNet	No	
Loss of date behavior	As wire	
Output protocols		
DMX512	Yes	
RDM (1)	Yes	No
Streaming ACN (incl. ETCNet3)	No	
Art-Net	No	
Pathport	No	
Strand ShowNet	No	
Radio technologies		
2.4 GHz	Yes	
5.8 GHz	No	

9 Technical data

	MicroBox F-1 Lite	MicroBox R-512 Lite
DMX capabilities		
Adaptive Frequency Hopping	Yes	
W-DMX G3 compatibility	Yes	
License free	Yes	
W-DMX Datasafe Redundancy	Yes	
Radio performance		
External antenna	No	
Standard range	Up to 200 m (standard antenna)	
Expandable range	Unlimited (optional antennas)	
Latency	< 5 ms	
Sensitivity (0.1% PER)	-97 dBm	
Modulation method	GFSK	
Max. power 2.4 GHz EIRP (2)	450 mW	
Max. number of universes	4	4
Input / output Opto Isolation	No	
Fully compliant USITT DMX512A	Yes	
W-DMX Invisi-wire	Yes	
Product functionality		
Front panel control	Yes	
W-DMX Uglybox compatible	Yes	
W-DMX Dongle compatible	Yes	
Free software updates	Yes	
Update over air	Yes	
Update over Dongle	Yes	
PC configurable	Yes	
Configurable over RDM	Yes	No

9.3 ProBox F-2500

ProBox F-2500	
Electrical data	
Regulations complied with	Certified Worldwide (FCC, ETL, ETSI, CE, Japan, China , Russia)
High voltage input	90 to 250 V _{AC}
Low voltage input	12 V _{DC}
Average current (TX mode)	450 to 700 mA / 12 V _{DC}
Average current (RX mode)	200 mA / 12 V _{DC}
DC power supply	Phoenix Gold Connector
Dimensions	
Format	19" rack format. Height: 1 U, depth: 120 mm
Weight	800 g
Environmental conditions	
Ambient temperature range (standard)	0°C to 45°C
Ambient temperature range (12 V DC)	0°C to 55°C
Humidity	90%
Input protocols	
DMX512	Yes
RDM (1)	Yes
Ethernet / PoE	Yes
Streaming ACN (incl. ETCNet3)	Yes
Art-Net	Yes
Pathport	Yes
Strand ShowNet	Yes
Loss of date behavior	As wire
Output protocols	
DMX512	Yes
RDM (1)	Yes
Streaming ACN (incl. ETCNet3)	Yes
Art-Net	Yes
Pathport	Yes
Strand ShowNet	Yes
Radio technologies	
2.4 GHz	Yes
5.8 GHz	Yes
Adaptive Frequency Hopping	Yes
W-DMX G3 compatibility	Yes
License free	Yes
W-DMX Datasafe Redundancy	Yes

9 Technical data

ProBox F-2500	
Radio performance	
External antenna	Yes
Standard range	Up to 750 m
Expandable range	Unlimited
Latency	< 5 ms
Sensitivity (0.1% PER)	-97 dBm
Modulation method	GPSK
Max. power 2.4 GHz EIRP (2)	450 mW
Max. power 5.8 GHz EIRP (2)	600 mW
DMX capabilities	
Max. number of universes	64
Input / output Opto Isolation	Yes
Fully compliant USITT DMX512A	Yes
W-DMX Invisi-wire	Yes
Product functionality	
Front panel control	Yes
W-DMX Uglybox compatible	Yes
W-DMX Dongle compatible	Yes
Free software updates	Yes
Update over air	Yes
Update over Dongle	Yes
PC configurable	Yes
Configurable over RDM	Yes