

Safety informations page 1

Technical features page 2

Photometric parameters page 2

Before using page 3

Main supply connection, DMX signal connection / fuses replacement page 4

Lamp installation, replacement page 5

Fixture setup page 6

DMX line and terminator page 7

DMX channels assignment page 8

Games table page 9

Technical drawings, spare parts, electric diagrams page 10

City Architectural Light **300**
COLOR
 PATENT PENDING





SAFETY INFORMATION

READ ALL CAUTIONS AND WARNINGS PRIOR TO OPERATE THIS EQUIPMENT.
INSTRUCTION TO PREVENT INJURY OR DAMAGE DUE TO ELECTRIC SHOCK, FIRE, MECHANICAL HAZARDS AND
UV RADIATION HAZARDS.

- PROTECTION AGAINST FIRE

- 1) This equipment is designed for use with the following lamp only: CDM-SA/T 150W/942 (PHILIPS)
DO NOT USE ANY OTHER TYPE LAMP!
- 2) Maintain minimum distance of 0.5 meter from walls or any other type flammable surfaces.
- 3) Maintain minimum distance to lighted objects of 5.0 meter.
- 4) Replace fuses only with the specified type and rating.
- 5) Do not install the spot close to heat sources. Do not lay the connection cable on the spot when it is warm.

- PROTECTION AGAINST ELECTRIC SHOCK

- 1) This equipment must be earthed.
- 2) Class I equipment. The power supply cord includes a protective earthing conductor as part of the cord.
- 3) For connection to the supply mains proceed as pict.2 page 4. The equipment must be connected to branch circuit having a circuit- breaker $I_n=16A$ $I_d=0.03A$ (230VAC)
- 4) Disconnect power before lamp's replacement or servicing (service personnel).

- PROTECTION AGAINST MECHANICAL HAZARDS

- 1) Use secondary safety chain when fixing this equipment.
- 2) Hot lamp explosion hazard. Do not open the equipment for 300 seconds after switching off.
- 3) Equipment surface may reach temperature up to 100°C. Allow about five minutes before handling.
- 4) Replace the lamp if it is damaged or thermally deformed.

- PROTECTION AGAINST UV RADIATION HAZARDS

- 1) Do not start on this equipment without lamp enclosure or if the protection screens, or ultraviolet screens are damaged.
- 2) The protection screens, the lenses, or the ultraviolet filters must be replaced if they are visibly damaged and their effectiveness has been reduced, for example, by cracks or deep scratches.
- 3) Do not look directly at the lamp while lamp is on.

INTRODUCTION

Thank you for choosing our CityColor300:

The fixture projects, thanks to an extremely efficient optic system (PATENT PENDING), a powerful light beam which can create numberless color shades. Its performances, in terms of luminosity and lighted surfaces, can reach incredible levels.

The CityColor300 comes in unique version:

- Art. 03021 CITYCOLOR300 for two CDM-T 150W discharge lamps

The fixture can work in automatic mode or in synchro mode, otherwise may be controlled by 8 bit DMX controllers

The input protocol is the DMX 512. To drive the fixture we suggest to use either our Control Show 512, Fancy or the Easy Control.

To make the most of its possibilities and for a correct functioning of this unit in the years to come, we suggest you to read carefully this manual before connecting or putting the spot into use. By doing so you will gain experience with its commands and connections and you will be easily able to use it.

YOUR REFERENCE

Always remember to give the serial number and to specify the model any time you address the seller for information or assistance.

BASIC KIT

The basic kit of the CityColor300 flood projector consist of:

- Projector
- User's manual
- Studio Due warranty
- Lamps (upon request)

WARNING

Check that the spot has not been damaged during transport. If it has been damaged or it does not work, address the seller. Whether the spot has been shipped to you directly, please contact the shipping company. Only the consignee (person or company) can claim for these damages.

TECHNICAL FEATURES

• LAMP

2x MasterColour CDM-SA/T 150W/942 (PHILIPS)
Color temperature: 4.200 °K
Average lamp life: 6.000 hours
Luminous flux: 2 x 14.000 lm
Burning position: Universal

• OPTIC COLOUR SYSTEM

Full CYM color mixing, unlimited variety of colours and shades
High resolution stepper motors

• BEAM ANGLE

Beam angle (50%): 45 °

• IP RATE

IP 66

• CONTROL INPUT

Standard interface: RS-485; opto-couplet input
Protocol: USITT DMX 512

• AUTOMODE

Stand-alone control: auto mode function master/slave (synchro mode) with 27 programs

• POWER SUPPLY

Rated voltage: 200-208-230-240; 50Hz. On request: 60Hz
Rated power: 500Va
Rated current: 2,2A (230V)

• POWER FACTOR CORRECTOR

built-in $\cos \phi$ 0.9

• FUSES

Lamp fuse: 5.0A/250V (delay time)
Electronic fuse: 2.0A/250V (delay time)

• DIMENSION (WxDxH)

mm 440x490x580

• WEIGHT

Kgs. 31,0

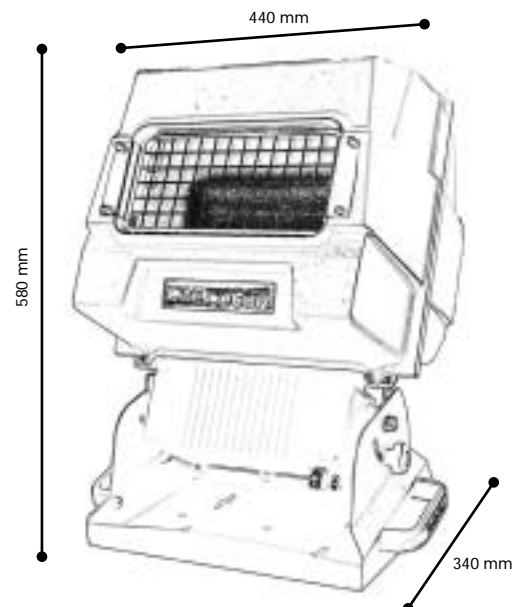
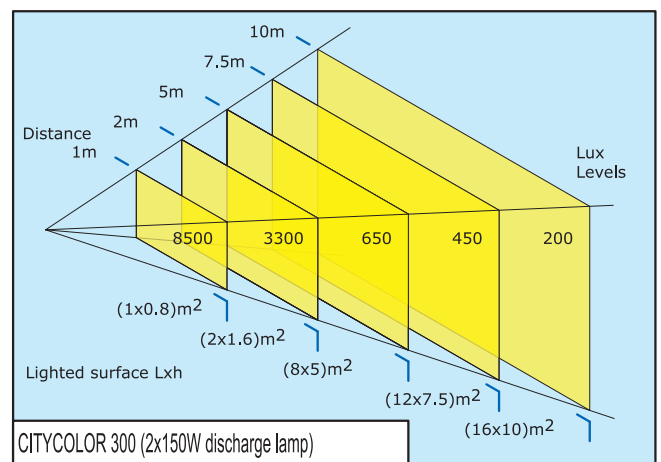

BEFORE USING



WARNING

The equipment must be earthed.

IP 66 rate: to ensure the declared IP rate choose the correct size of the cables (DMX cables: size from 3 to 6.5 mm - Main Power cables: size from 6 to 12 mm).

All the gaskets and the glass must be kept in full working order.

If the fixture is not connected with DMX cables DON'T REMOVE the green protection.

Read all cautions and warnings to page 1 prior to install this equipment. Particularly, read the follow:

- 1) Disconnect power before lamp's replacement or servicing (service personnel)
- 2) Do not open the lamp cover for 300 seconds after switching off
- 3) Wear gloves and goggles to re-lamping or to work inside the unit (service personnel)
- 4) The equipment must be connected to branch circuit having a circuit-breaker $I_n=16A \cdot I_d=0.03A$ (230VAC)
- 5) Make sure that the main voltage and frequency correspond to rated values on the data label, pict.1.
If is necessary set-up the red connector to the right position, pict.1a/1b.
In this case unscrews the screws (F) and remove the system board to operate (pict.1c).

Before any operation on the fixture

- a) Do not install the spot close to the heat sources. Do not lay the connection cable on the spot when it is warm.
- b) This unit must be positioned as to allow its ventilation.
- c) The unit must be positioned at least 1 m from walls or other flammable surfaces and minimum 5 meters to lighted objects.

-External surface temperature T_a 45°C:

- After 5 minutes work; $T_c=75^\circ\text{C}$.
- Once the thermic balance has been obtained; $T_c=100^\circ\text{C}$.

- d) Replace the lamp when is exhausted (6000 h) to avoid bad performances of the fixture or that the optic system is damaged by the lamp explosion. It must be replaced if it has been damaged or thermally deformed
- e) The protection screens, the lenses, or the ultraviolet filters must be replaced if they are visibly damaged and their effectiveness has been reduced, for example, by cracks or deep scratches.
- f) In case of installation of the spot to a truss, check carefully that the fixture is fixed with a chain to both truss and unit.
- g) Do not handle the spot by taking it by the head, but always by using the handles.

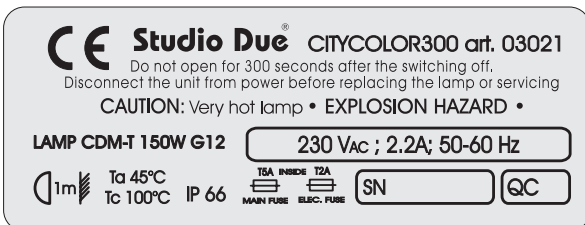

pict.1

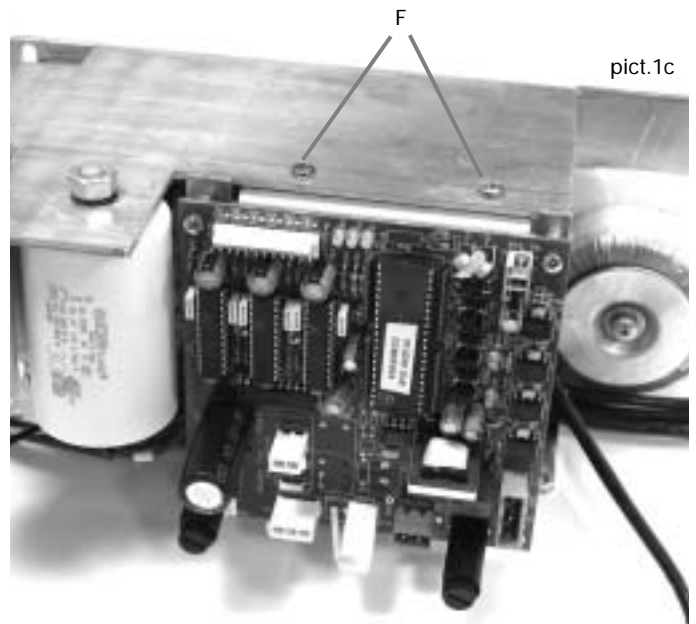

pict.1c

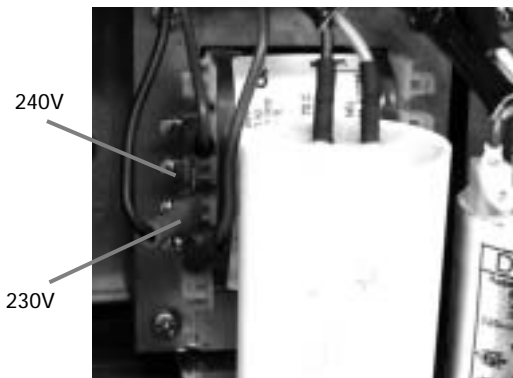

pict.1a



pict.1b

MAIN POWER AND DMX CONNECTION

- 1) Disconnect power before lamp's replacement or servicing (service personnel)
- 1) Open the rear box cover.

- The fixture can be equipped for 200/208/230/240Vac, 50Hz main voltage (pict.1a/1b). On request 60Hz.

- 3) Insert the main power cable into the PG (pic.3), connect the cable to the main power connector (pic2) and tighten the PG.
- 3) If necessary (synchro-mode), insert the the DMX cables into the PG (pic.3), connect the cables to the DMX connector (pic2) and tighten the PG.
- 4) Close the box cover with care, pict.3.

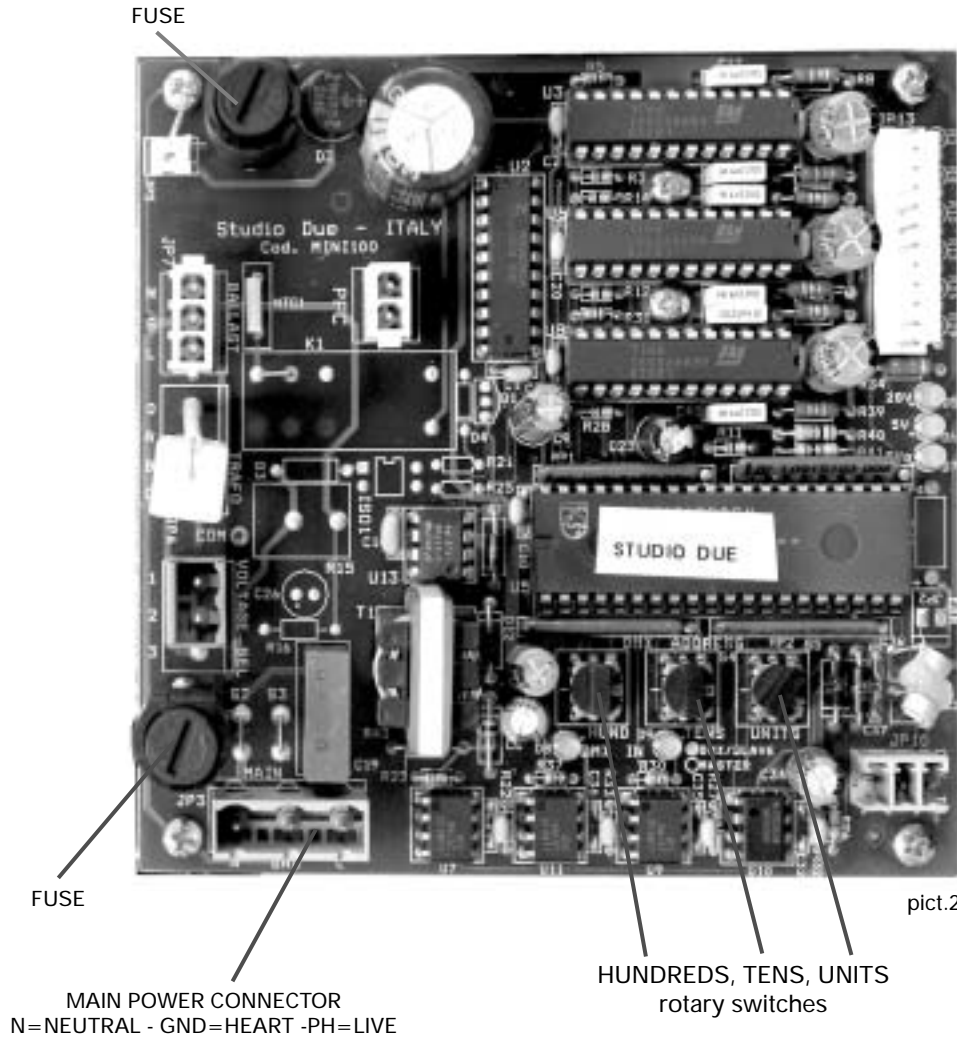

PIN	WIRE	SIGNAL
1	SHIELD	GROUND/RETURN/OV
2	INNER CONDUCTOR	DATA COMPLEMENT (-, INVERTED)
3	INNER CONDUCTOR	DATA COMPLEMENT (-, NOT INVERTED)

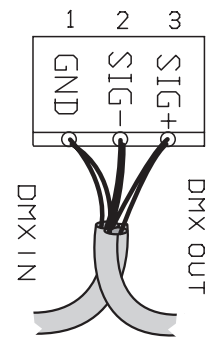

FUSE

MAIN POWER CONNECTOR
N=NEUTRAL - GND=HEART -PH=LIVE

HUNDREDS, TENS, UNITS
rotary switches

DMX CONNECTOR

pict.2

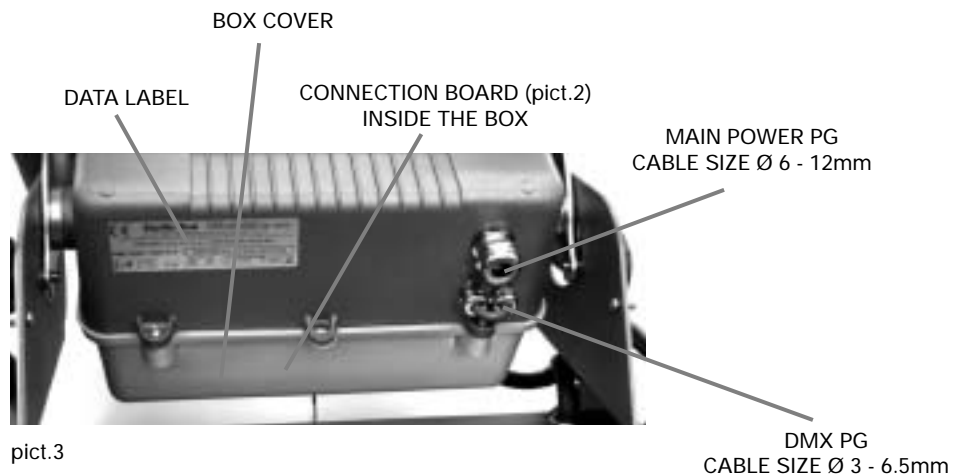

pict.3

LAMP'S INSTALLATION OR REPLACEMENT

- 1) Disconnect power before lamp's replacement. Wear gloves and goggles.
- 2) Tighten the two pommels (P) and lock the fixture's head as shown in pict.4
- 3) Unscrews the 4 screws (A) and remove the head cover, pict.4
- 4) Remove the nuts (S) to the dichroic group and open it with care, pict.5
- 5) Unscrews the screws (S1) and remove the two lateral reflectors (C1), pict.6
- 6) Insert the lamp into the lampholder (D) and repeat this procedure for the other lamp, pict.7
- 7) Do not touch the quartz bulb with fingers. If this happens, clean the bulb before use with dry cloth and alcohol.
- 8) Replace the two lateral reflectors (C1) and fix it with screws (S1)
- 9) Close the dichroic group and screw the 4 screws (A) tightly.

 **WARNING**

In case of replacement of the lamp or maintenance, do not open the fixture unless 5 minutes have passed from the switching off. This operation has to be done when the apparatus is disconnected from the mains supply

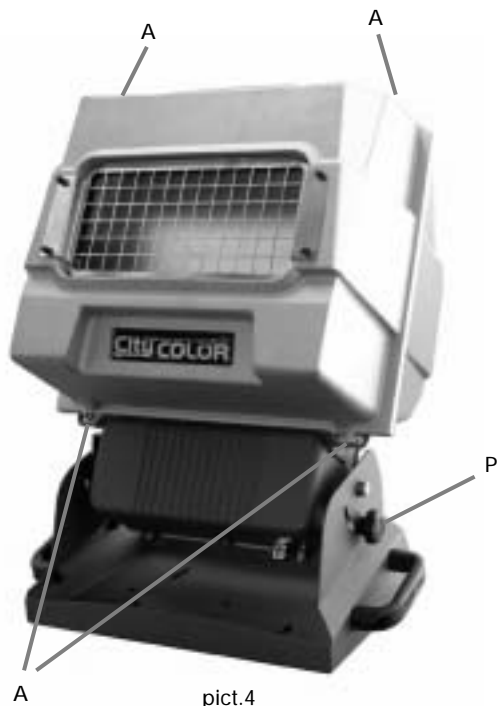

pict.4

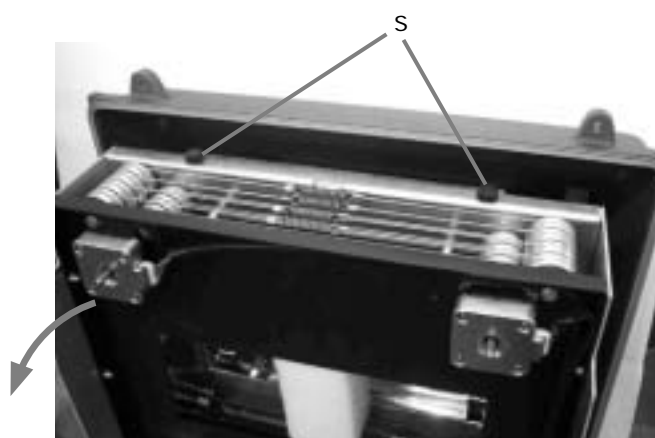

pict.5

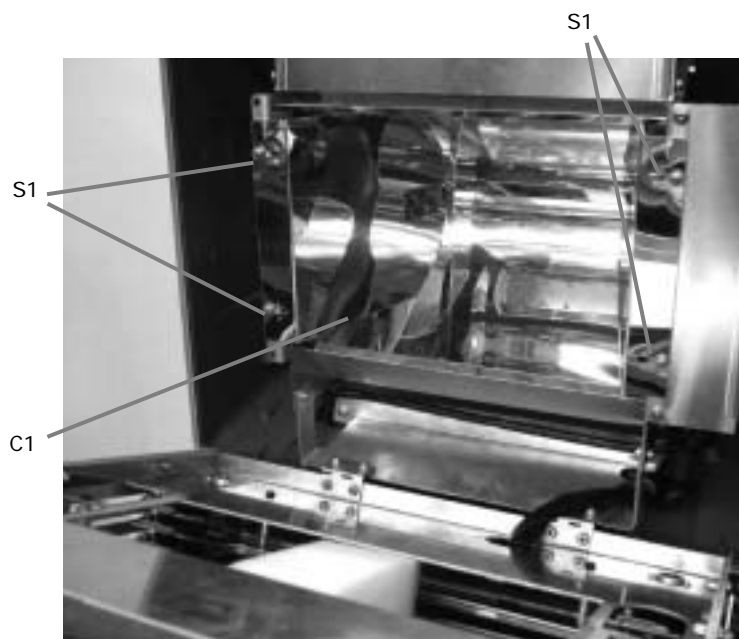

pict.6



pict.7

D

DMX TERMINAL LINE

The wrong connection of the terminal line or its non-connection are probably the most frequent reasons for the defective functioning of the DMX line. The terminator is a terminal resistor fitted at the end of the cable furthest from the transmitter (see pict. 9).

The terminal resistor should have the same value as the impedance of the connection cable.

We suggest to use a terminal with a 100 ohm resistor.

It is recommended that all DMX 512 systems have the terminal resistor fitted in the DMX output of the last fixture.

FIXTURE SETUP



WARNING

HIGH VOLTAGE!

Always disconnect the mains supply before opening the connections area.

• DMX 512 CONTROL

- 1) Connect the DMX data cable coming from the controller to the DMX-IN connector on the electronic board (see pict. 2 page 4).
- 2) Connect the DMX data cable to the DMX-OUT connector on the electronic board to control the next FIXTURE (see pict. 2 page 4).
- 3) Select the DMX starting address by operating on the rotary switches (UNITS, TENS, HUNDREDS).

DMX 512 CHANNELS ASSIGNEMENT

The rotating switches to assign the channels in the FIXTURE in DMX 512 are located on the printed circuit of the electronics which is inside the connections area.

There are three rotating switches, and each one is numbered from 0 to 9: one for the UNITS, one for the TENS, one for the HUNDREDS.

In the picture below it is shown the position of the three switches when using four FIXTURES in DMX 512.

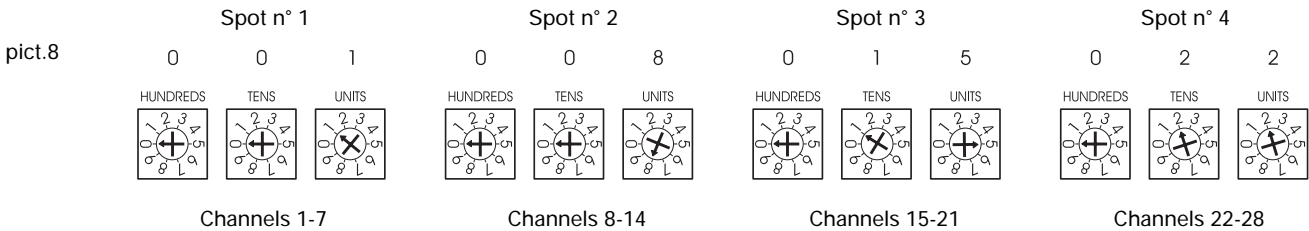

• AUTO - MODE CONTROL

- 1) Set n° 6 on the HUNDREDS rotary switch (MASTER).
- 2) Choose the games by operating on the UNITS and TENS rotary switches.
Available games: from n° 1 to n° 27 (see page 9). Game n° 11 is the one which enables all the colors.

• SYNCHRO - MODE CONTROL

(pict. below)

- 1) Interconnect all the MINICITY 100 (max 32) by using the DMX standard cables.
- 2) Set the first MINICITY 100 as MASTER by setting n° 6 on the HUNDREDS rotary switch.
- 3) Choose the games by operating on the UNITS and TENS rotary switches (on MASTER fixture). Games: from n° 1 to n° 27
- 4) Set all the rest of the MINICITY 100 as SLAVE by setting n° 7 on the HUNDREDS rotary switch.

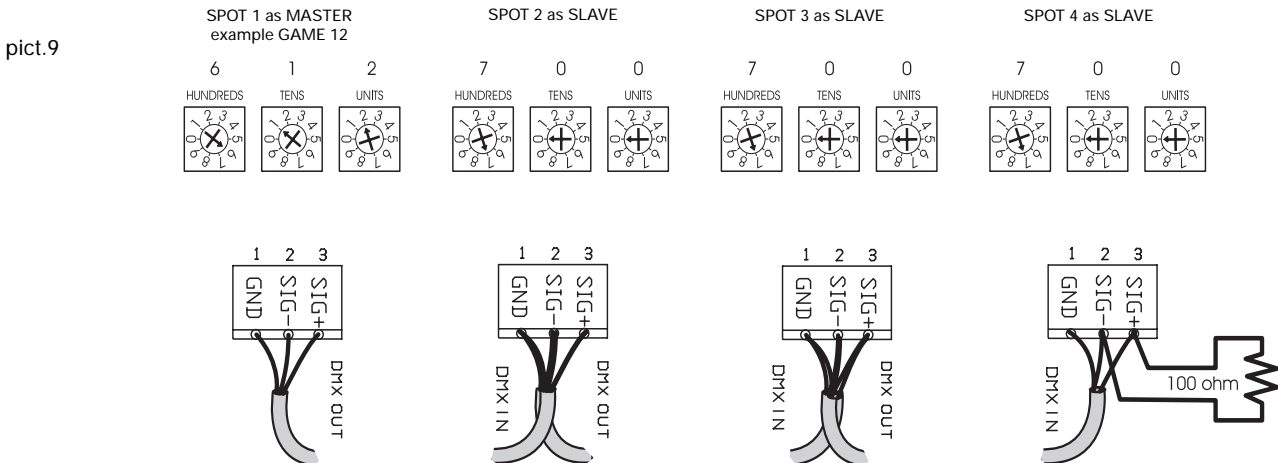

! WARNING

The wrong connection of the terminal line or its non-connection are probably the most frequent reasons for the defective functioning of the DMX line. The terminator is a resistor fitted between the two "data" lines (shown in pict.9, page 6) at the end of the cable furthest from the transmitter. The terminator resistor should have the same value as the impedance of the connection cable. We supply a terminal with a 100 Ohm resistor. It is recommended that all DMX 512 systems have the termination resistor at the end of the line.

EXAMPLE 1
Connection controller-spot with 1 DMX 512 output

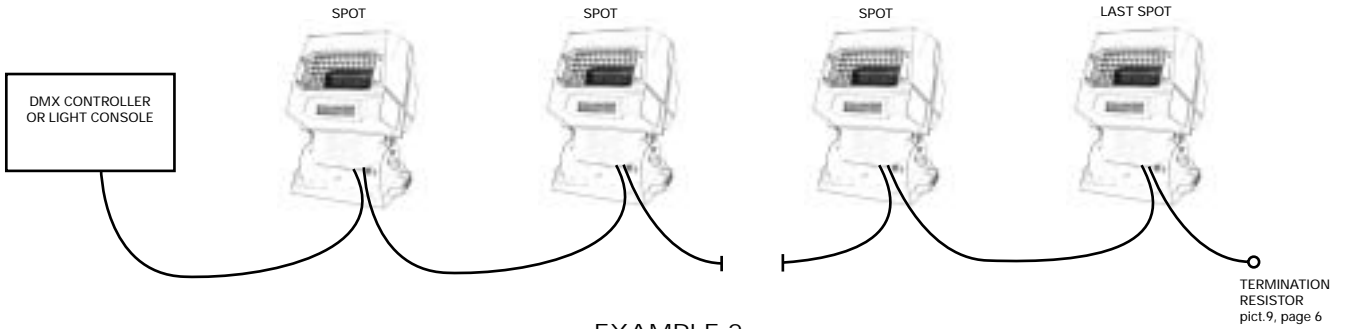

EXAMPLE 2
Connection controller-spot to one DMX 512 output over 150mts long

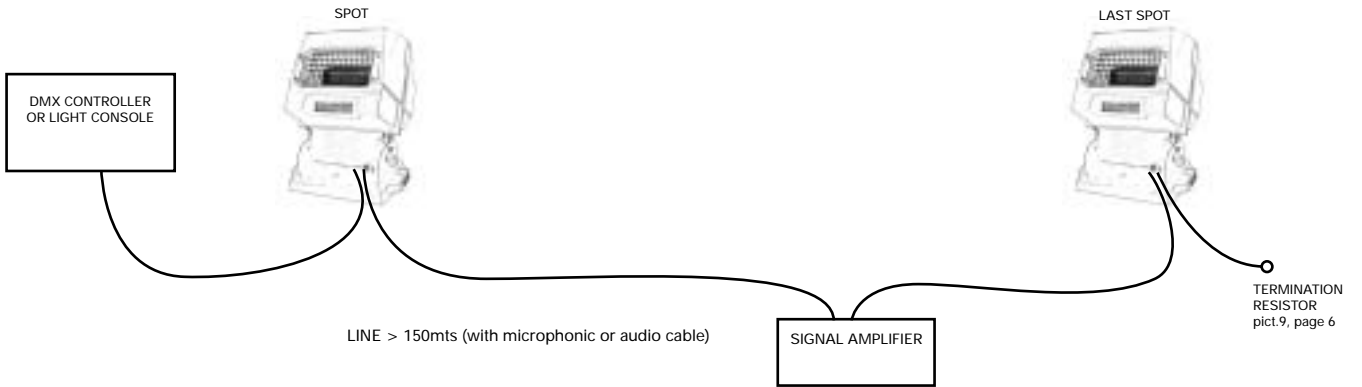

EXAMPLE OF CONNECTION AND SETTING OF 4 FIXTURE IN SYNCHRO - MODE

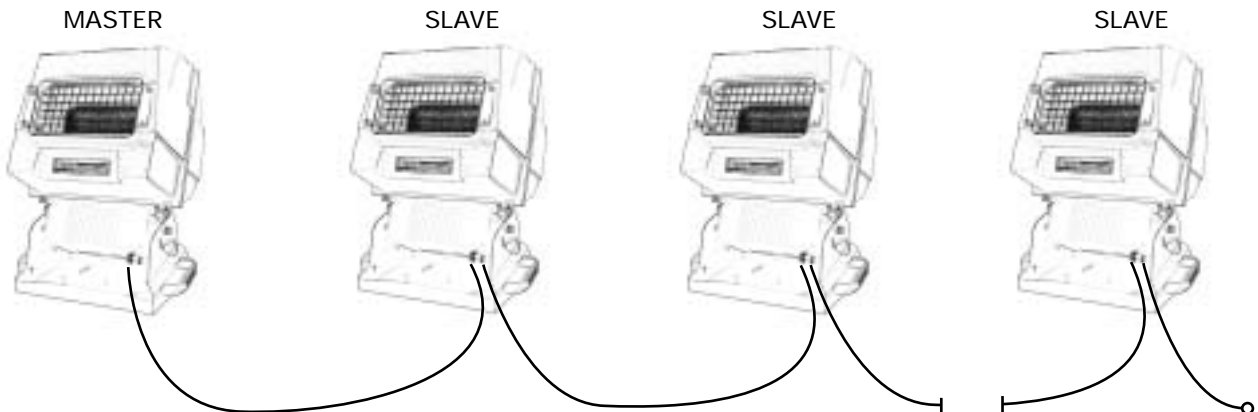

! WARNING

The cables are the same as the DMX standard cable

DMX LISTING • LISTA VALORI DMX				
DMX CHANNEL	FUNCTIONS	DESCRIPTION	DECIMAL	PERCENT
1	MOTOR SPEED	MOVEMENT SPEED Slow Mid 2 Mid 1 Fast	0..63 64..127 128..191 192..255	< 25% 25%..50% 50%..75% > 75%
2	CYAN	CONTINUOUSLY VARIABLE White Full color	0 255	0% 100%
3	YELLOW	CONTINUOUSLY VARIABLE White Full color	0 255	0% 100%
4	MAGENTA	CONTINUOUSLY VARIABLE White Full color	0 255	0% 100%
5	NOT USED	-----	-----	-----
6	BASIC COLORS/ RAINBOW	Color mixing Cyan Yellow Magenta Blue Red Green Color mix sequence (slow) Color mix sequence (mid) Color mix sequence (fast)	0..25 26..51 52..77 78..103 104..129 130..155 156..181 182..207 208..233 234..255	0..10% 10%..20% 20%..30% 30%..40% 40%..50% 50%..60% 60%..70% 70%..80% 80%..90% 90%..100%
7	REMOTE RESET	Normal Reset	0..127 128..191	0..50% 50..90%

GAMES TABLE

Here below you can find the complete list of the available games (ref. page 8)

PROGRAM	FUNCTIONS
01	Red Magenta Yellow –color mix sequence (slow – 30sec)
02	Red Magenta Yellow + White color mix sequence (slow – 30sec)
03	Green Cyan Yellow – color mix sequence (slow – 30sec)
04	Green Cyan Yellow + White color mix sequence (slow – 30sec)
05	Blue Cyan Magenta – color mix sequence (slow – 30sec)
06	Blue Cyan Magenta + White color mix sequence (slow – 30sec)
07	All colors – colr mix sequence (slow – 30sec)
08	All colors + White color mix sequence (slow – 30sec)
09	All colors – color mix sequence (mid – 20sec)
10	All colors + White color mix sequence (mid – 20sec)
11	All colors color mix sequence (fast – 10sec)
12	All colors + White mix sequence (fast – 10sec)
13	All colors + White mix sequence (fast – 10sec)
14	Basic colors (6 sec.)
15	Basic colors + White (6 sec.)
16	Wood (fix)
17	Magenta (fix)
18	Red (fix)
19	Light Red (fix)
20	Orange (fix)
21	Yellow (fix)
22	Cyan (fix)
23	Light Cyan (fix)
24	Green (fix)
25	Light Green (fix)
26	White (fix)
27	Ten colors + white (slow - 1 Minute)

City COLOR³⁰⁰

Architectural Light

PATENT PENDING

SPARE PARTS, TECHNICAL DRAWINGS and SCHEMATIC DIAGRAMS
PARTI DI RICAMBIO, DISEGNI TECNICI e SCHEMI ELETTRICI

N.	Description
1	Steel grid
2	Aluminium cover
2/a	Adhesive
3	Tempered satin glass
4	Reflector (upper / lower)
5	Lateral unshaped reflector
6	Main reflector
7	Main reflector support (fan side)
8	Main reflector support
9	Upper Z plate
10	Lower Z plate
11	Nut
12	Lamp socket support
13	Lamp socket
14	Base/head cable complete
15	PG 7
16	PG 13
17	Thermal switch 100° NC
18	Thermal switch 110° NC
19	Support fan Z plate
20	Head fan
21	Aluminium cover gasket
22	Head
23	Main plate
24	Ballast support plate
25	Igniter
27	Condenser
28	Ballast
31	Electronics cover gasket (head)
32	Electronics cover (head)
35	Bracket screw
36	Pommel
37	Handle
38	DX lateral bracket
39	DX lateral steel plate
40	SX lateral steel plate
41	Head stop spacer
42	DX head stop
42/a	SX head stop
43	Spacer
44	DMX control panel steel plate
45	DMX panel adhesive
46	Base plate
47	Display PC board
48	Motor PC board
48/a	DMX PC board support plate
49	Electronics cover gasket (base)
50	Electronics cover (base)
51	SX lateral bracket
53	Transformer
54	CC300 PC board support plate
55	CC300 PC board

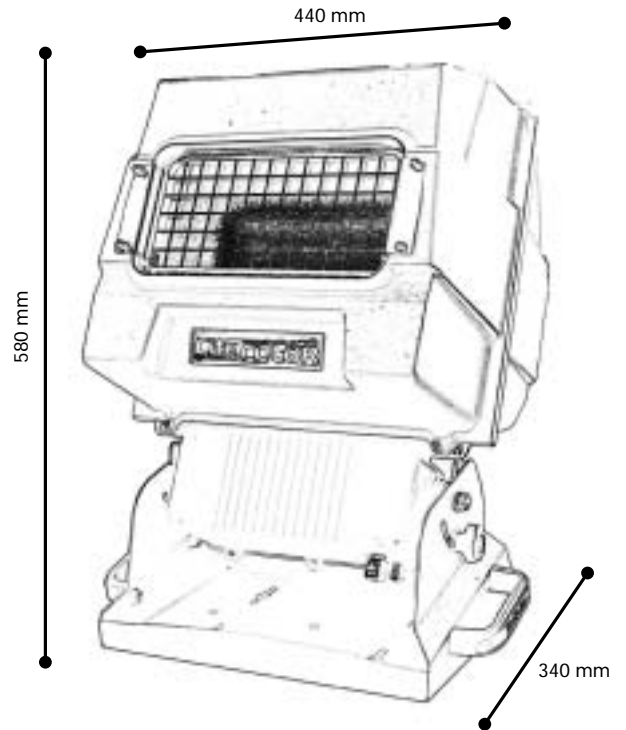

N.	Description
60	Rear motor panel
61	Spacer
62	Spacer protection
63	Hinge
64	Wire
65	Upper yellow color blade
66	Lower yellow color blade
67	Wire fixing plate
68	Wire fixing plate spacer
69	Teflon friction
70	Upper cyan color blade
71	Lower cyan color blade
72	Upper magenta color blade
73	Lower magenta color blade
76	Motor
77	Front color/motor panel
78	Connectors board protection
79	Dichroics guide plate
80	Motor connection board
81	Screw
92	Ball bearing support
93	Spacer
94	Pulley (wire fixing)
95	Spacer
96	Ball bearing H4
97	Pulley

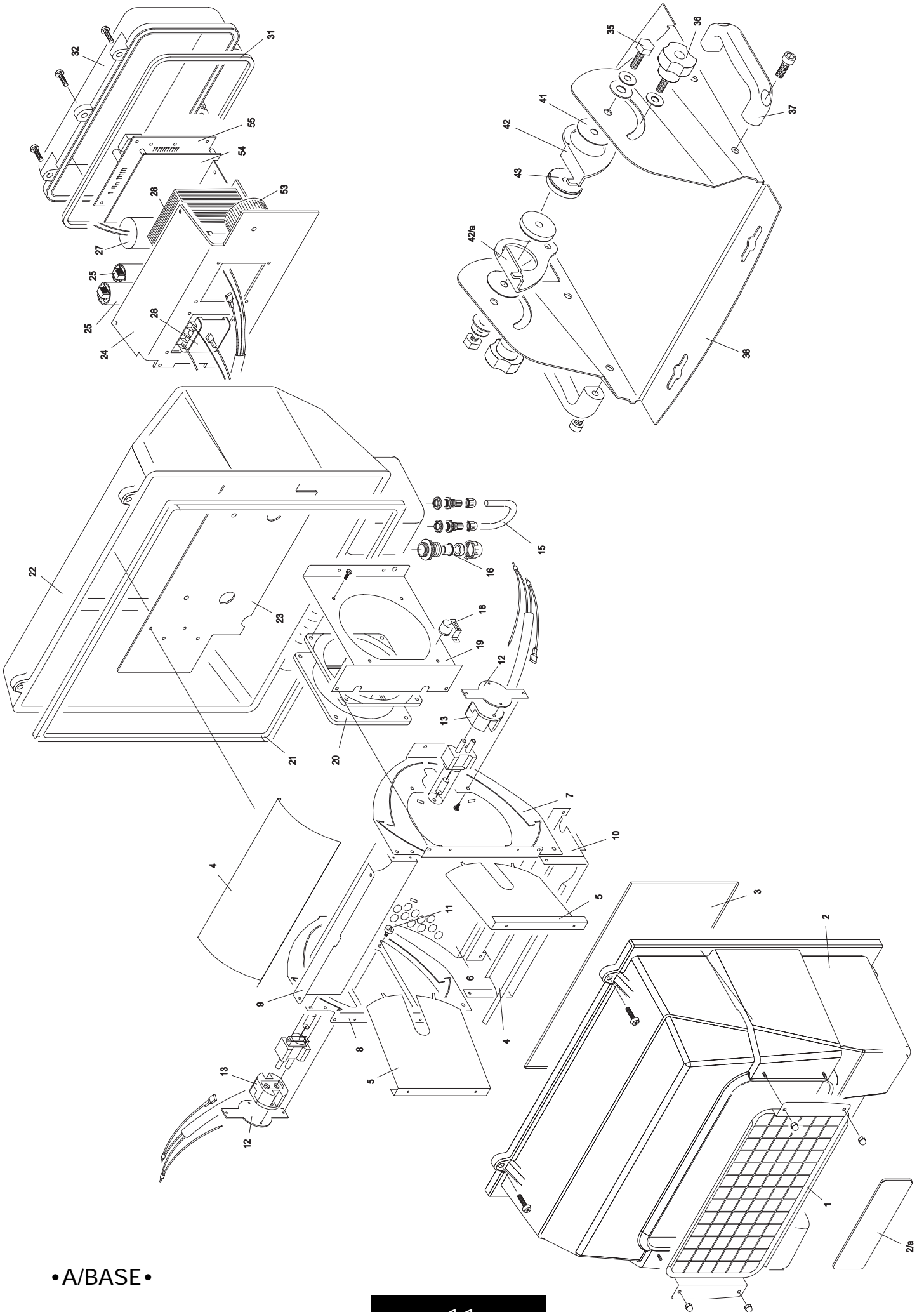

•A/BASE•

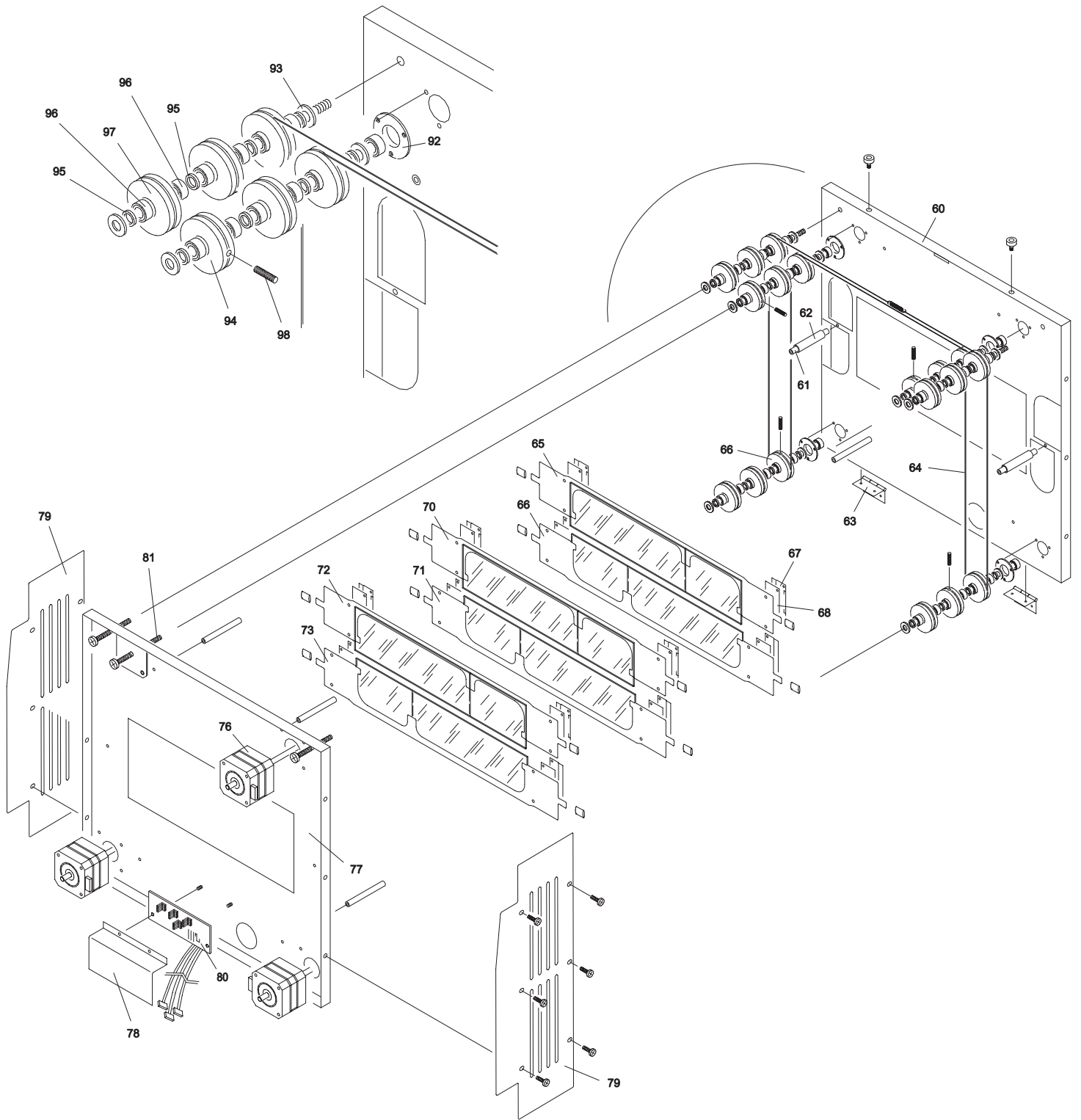

•B/HEAD•

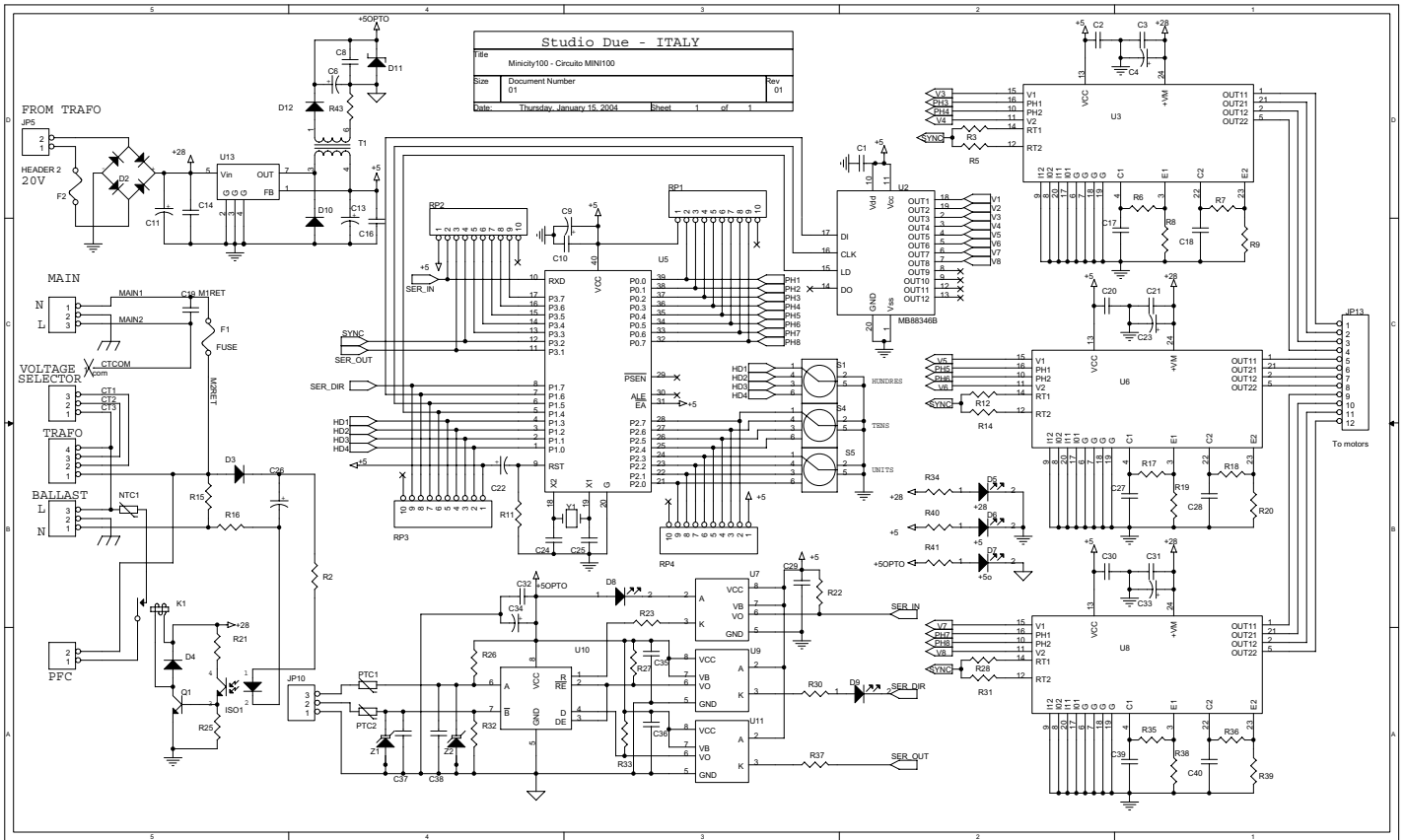

•mini100ed•

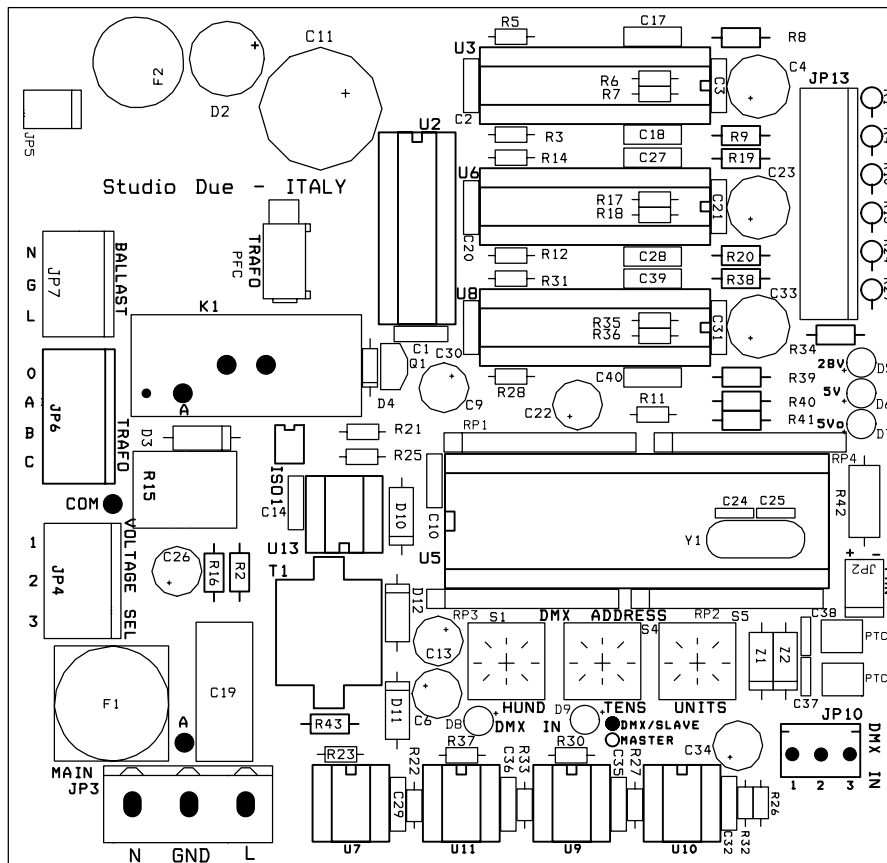

•mini100pcb•

