

SPar Light LED

Small Par LED Wash



Information specifically for:

- DL-SPAR18TC/B Spar Light 1x8w RGB Tri-Color, Black
- DL-SPAR18QW/B Spar Light 1x8w RGBW Quad Color, Black
- DL-SPAR18VW/B Spar Light 1x8w CW/WW Variable White, Black
- DL-SPAR17UV/B Spar Light 1x7w UV Ultraviolet Blacklight, Black

This manual contains important information.
Please read before operating fixture.



IMPORTANT INFORMATION

Save original packing and documentation for warranty, service and return issues.

Limited Warranty: This warranty covers defects or malfunctions in this equipment. This warranty lasts for a period of two years from date of purchase. It is the owner's responsibility to provide invoices for proof of purchase, purchase date and dealer or distributor. If purchase date cannot be provided, warranty period will start at manufacture date. It is the sole discretion of Techni-Lux to repair or replace parts or equipment. All shipping will be paid by purchaser. This warranty does not cover lamps, fuses, belts, power semiconductors, relays, cleaning, standard maintenance adjustments or normal wear items or any problem resulting from the following: improper wiring, incorrect voltage (including low or over voltage conditions and lightning), abuse, misuse, improper maintenance or an act of God or damage resulting from shipping. Warranty will be null and void if the product is altered, modified, misused, damaged, or subjected to unauthorized repairs. Lamps are covered by relevant manufacturer warranty. This warranty gives you specific legal rights, and you may also have other rights which vary from state to state. Any liability for consequential and incidental damages is expressly disclaimed. No other warranty, expressed or implied is made. Techni-Lux liability in all events is limited to, and shall not exceed, the purchase price paid.

Returning equipment and Repairs: All returns must be accompanied by a Return Merchandise Authorization (RMA) number and sent pre-paid. Contact the dealer or Techni-Lux directly to obtain an RMA. The RMA number must be clearly listed on the shipping label. Due care must be exercised in packing all merchandise to be returned. All repairs must be accompanied by a written explanation of the claimed problem or error encountered. Techni-Lux is solely responsible for determining a product's eligibility for coverage under warranty. If returning for consideration of credit, all accessories and documentation, original protective material and cartons must be included and the equipment, packing and carton must be in new resalable condition. Credit for returned merchandise will be issued at the lowest current price and is subject to a restocking fee. No returns accepted on discontinued items. Techni-Lux is not responsible for merchandise damaged in transit and reserves the right to refuse any return that is damaged by the carrier, not accompanied by a Return Authorization Number (RMA#) or sent by freight collect.

Claims: All claims must be made within seven (7) days of receipt of merchandise. Any physical damage must be reported to carrier upon receipt of merchandise.

Please record the following information for future reference:

Model Number: DL-SPAR _____

Serial Number: _____

Dealer: _____

Date of Purchase: _____

www.Techni-Lux.com

Table of Contents

Fixture Features	4
Specifications	5
Unpacking	6
Purpose of Manual	6
Dimensions Reference	7
Mounting	7
Installing Lenses	7
Beam Chart	8
Beam Accessories	8
Cabling Diagram	9
Power and Data	10
<i>Power</i>	<i>10</i>
Configuration Setup	10
<i>RDM Data</i>	<i>10</i>
<i>RDM Considerations</i>	<i>10</i>
<i>Fixture Parameter Options</i>	<i>11</i>
<i>RDM Settings and Parameters</i>	<i>12</i>
Channel Assignments and Values - DMX/RDM	13
Maintenance	15
Troubleshooting	15
DMX-512 Background	16
Accessory Items (sold separately)	17

Fixture Features

- Compact single lens Par Light
- COB LED Lighting Source 25,000 hours: 1x8W for RGB, RGBW, VW
1x7W for UV
- Interchangeable lenses and beam accessories available to optimize output
- RDM, DMX, and Standalone modes with Soft Start Option
- Configurable for DMX hold or black out on data loss
- Numerous built-in automatic effects and flicker functions
- Linear Dimming 0-100% and adjustable speed electronic strobe
- Mounting yoke for easy focus and installation
- Combined data and power 4-Pin locking IP65 cables
- In and out cabling for easy daisy chaining
- Robust side knobs for accurate aiming and positioning
- Enabled Licensing Program - innovated using multiple patents licensed from Philips Signify for PWM, DMX, RGB color mixing and heatsinking
- CE and RoHS Certified



Specifications

Model Codes	DL-SPAR18TC/B	DL-SPAR18QW/B	DL-SPAR18VW/B	DL-SPAR17UV/B
OPTICAL				
Light Source	COB LED RGB Red, Green, Blue	COB LED RGBW Red, Green, Blue, White	COB LED WW/CW Warm White 3000k Cool White 6500k	COB LED UV Ultraviolet/Blacklight (385nm)
Color Rendering	--	--	CRI: ≥92	--
Beam Angle	Included: 15° / 25° Optional: 8° / 45° / 60°			45° UV Specific
Average Life	25,000 hrs			
ELECTRICAL				
Input Voltage	Low Voltage: minimum 12Vdc, maximum 24Vdc			
Power Consumption	8 watts		7 watts	
Current Draw	0.7 Amps			
Connections	4 pin male plug in and female connector out			
Cable Length	6 inch in/out			
CONTROL				
Data Connection	4 pin IP65 Locking Connectors			
Data Control	DMX 512 / RDM			
DMX Channels	3/6	4/7	2/5	1/3
Settings	Only through RDM			
Modes	Standalone with macros or DMX with 2 selectable modes			
Standalone Macro Effects	Static Color • Strobe Effect • Double Strobe Effect • Flame Flicker • Power Surge Ember Effect • Pulse Effect • Blink Effect • Color Wave • Color Chase			
Features	On DMX Loss: Hold, Off, Standalone, Slow Fade-up to Full			
PHYSICAL				
Dimensions	Overall Max: 5.4" x 3.25" x 2.5" (137 x 82.5 x 63.5mm)			
Weight	0.98 lbs (0.45 kgs)			
Housing	Aluminum			
Hardware	Stainless Steel			
U Bracket	Adjustable yoke with 3/16" (4.8mm) mounting hole			
Rigging	Dual position for safeties or mounting, 3/16" (4.8mm) holes w/ 1-1/4" x 1/4" slot			
Orientation	Any			
Finish Color	/B - Black			
OTHER				
Insulation Rating	IP65			
Cooling	Passive			
Certification	CE, RoHS			
Warranty	2 years			

Unpacking

Immediately upon receipt, carefully unpack and inspect the fixture to verify that all parts are present and have been received in good condition. If any parts appear damaged or the shipping carton shows signs of mishandling, notify the shipper immediately. Retain carton and all packing material for inspection. In the event that the merchandise is to be returned, the original carton and packing must be used. The customer will be billed for a new carton and packing if merchandise is received without the original carton and packing.

Claims

It is the customer's obligation to notify the Freight Carrier or Shipping Company of any physical damage or signs of mishandling immediately upon receipt. Damage incurred in shipping is the responsibility of the Freight Carrier or Shipping Company. All other claims not related to damage incurred during shipping must be made to the Dealer or Distributor within 7 days of receiving merchandise.

Returns

Returned merchandise must be in the original packaging with a Return Merchandise Authorization number (RMA) clearly listed on the shipping label. Items sent by Freight Collect or without an RMA number will be refused. Call your sales person and request an RMA prior to shipping. Be prepared to provide the model number, serial number and a description of the nature of the return. Shipping damage on returns resulting from inadequate packaging is the customer's responsibility. Customer will be charged additional shipping charges to return products received in non-original packaging and/or cartons.

Purpose of Manual

The purpose of this manual is to explain the necessary steps for using this fixture properly and to assure peak performance of said product and its functions. It is intended for use as a reference by a fully qualified electrician, technician, or lighting professional. This manual should never be considered a substitute for any provision of a regulation, state, and/or local code. The responsibility of complying with all state and local laws, ordinances, codes, and regulations in regards to installation, maintenance, and operation of this product lies with the buyer and handler of the product. The instructions and precautions set forth in this manual are not necessarily inclusive of or relevant to all applications. Please read the entire manual to fully understand the safe use of this product.

Dimensions Reference

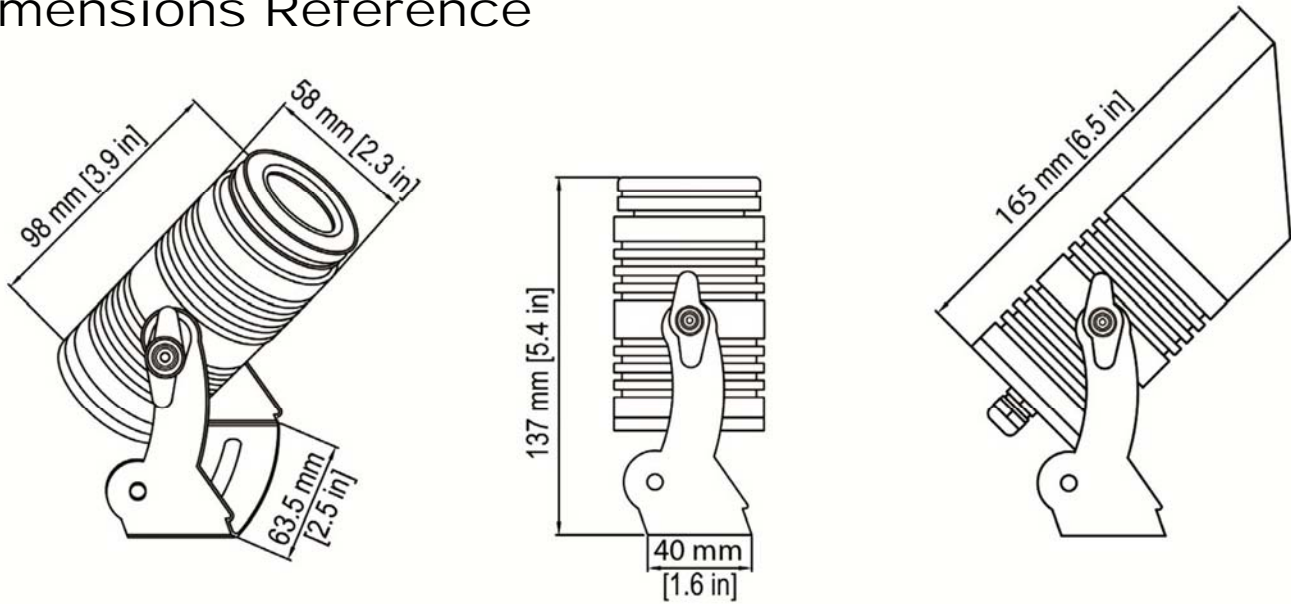

Mounting

Consider access for routine maintenance, adjustments, minimum distances, and to prevent submersion in water or restricted ventilation and extreme temperature changes. Fixture may be mounted in any orientation. Use an appropriate clamp or fastener that fits integrated 3/16" (4.8mm) mounting holes. Secure all cables properly and keep away from hot surfaces to prevent heat damage and trip hazards. If unsure, consult a Professional.

Installing Lenses

All SPAR18 fixtures ship with an installed 25-degree lens, and an additional 15-degree lens in the packaging. Other lens options are available and sold separately. The SPAR17 UV comes with a unique 45-degree lens. There are no other optional lens for the UV unit.

Markings indicate lens beam angle.

DL-SPAR18 Lenses	
ZOLE1040	8°
ZOLE1041	15°
ZOLE1042	25°
ZOLE1045	45°
ZOLE1046	60°
<i>Lenses are not compatible with Ultraviolet DL-SPAR17UV Fixture</i>	



1. Unscrew and remove front lens cover.
2. Gently remove installed lens.
3. Insert replacement lens, carefully rotating to align and fully seat square cutout to the LED base.
4. Replace and gently tighten lens cover.

Beam Chart

Approximate Diameter at Distance for given Beam Angle. Chart can be read as feet or meters.

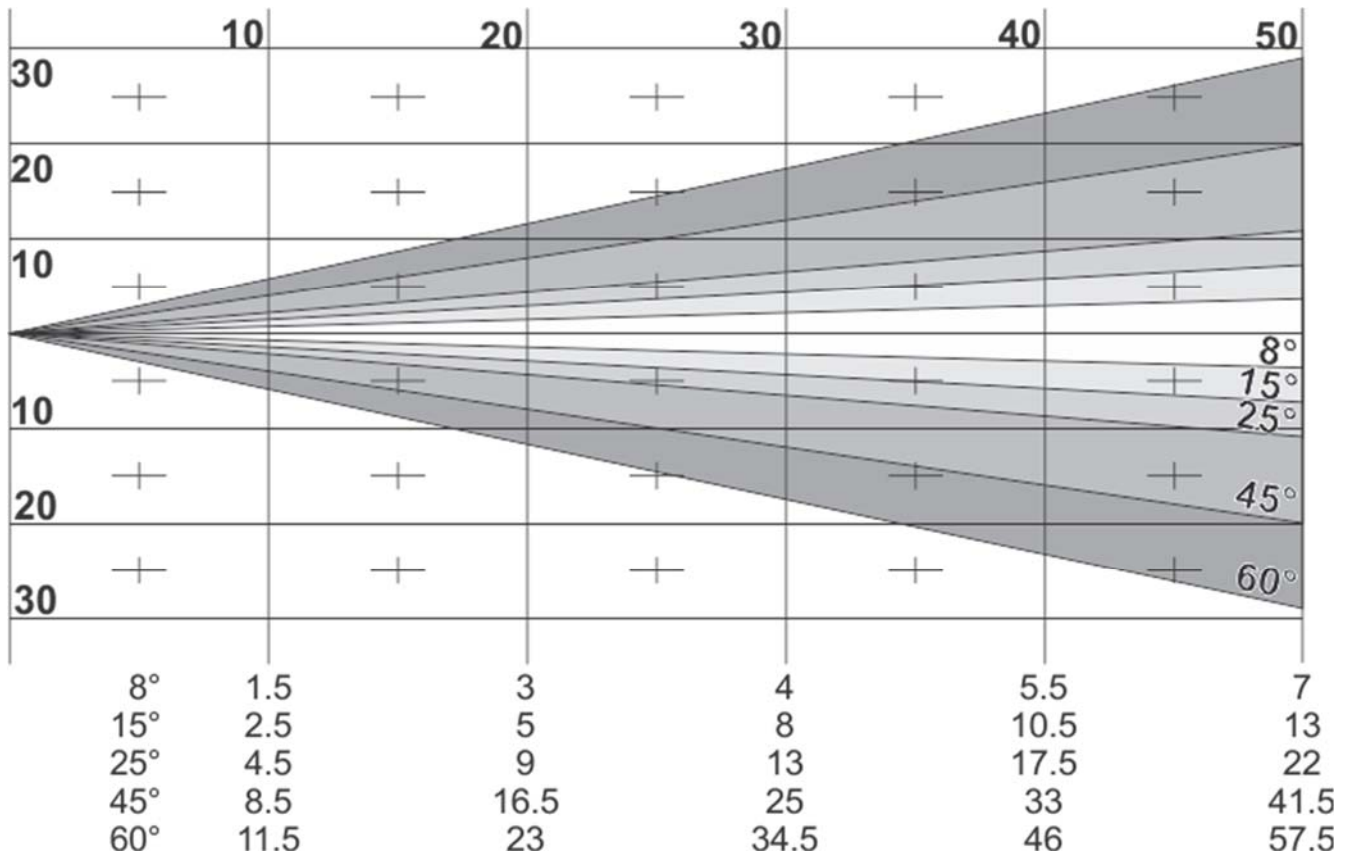

Beam Accessories

Honeycomb Louver or Full Top Hat Snoot can be utilized to mitigate light spill or side glare in certain applications.

Accessories		
TA-FHATSPAR/B	Full Top Hat Snoot. 58mm x 83mm Mounting set screws included.	Mounts to the Lens Cover's groove. Use 1.5mm hex driver to tighten set screws.
TA-HONCOMB/SPAR	Honey Comb Louver 1.5mm	Installs between Lens and Lens Cover.

Cabling Diagram

Proprietary IP65 4-pin Connectors and wire are used to pass both power and RDM/DMX data over a single cable. A variety of cables and adapters are available for data and power interconnections. Reference letters below on the Accessory Items table on page 17.

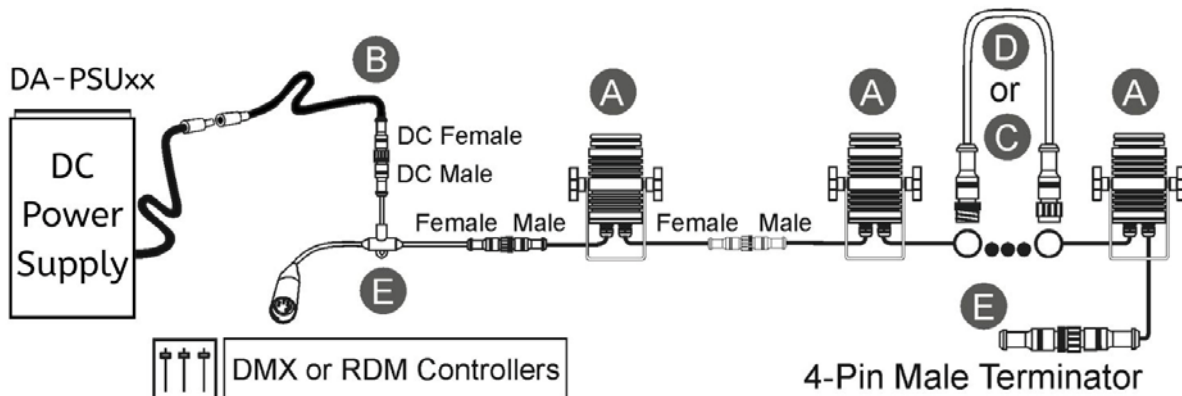
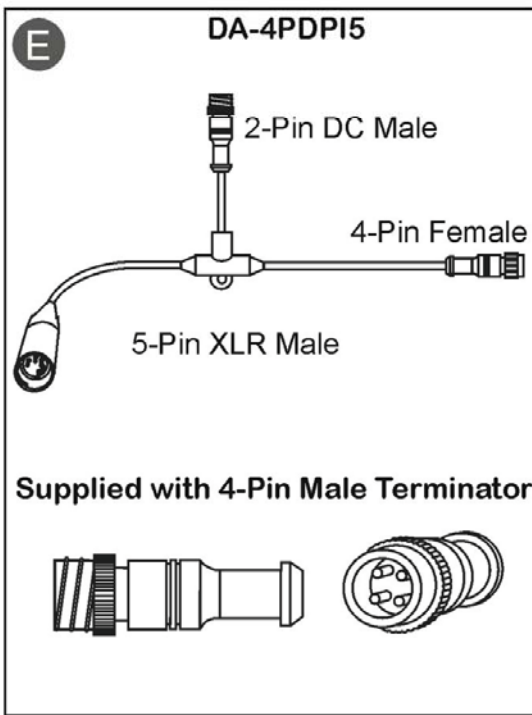
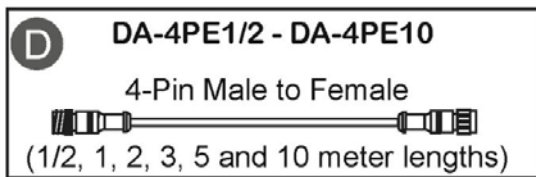
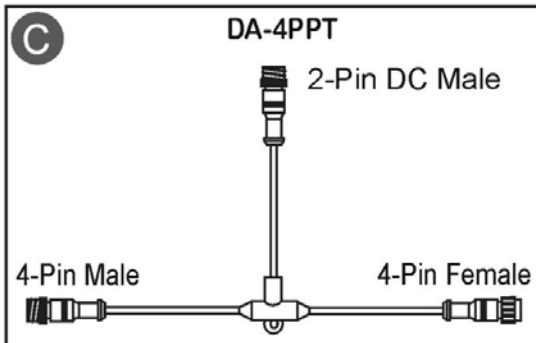
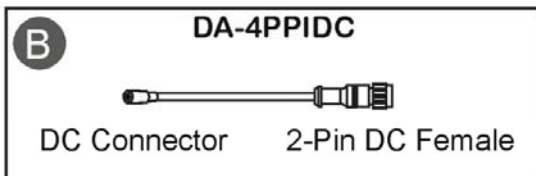
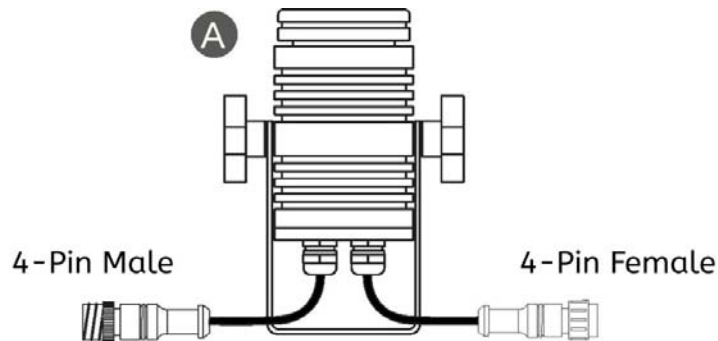

Power and Data

Power and data pass to fixtures over a single cable connection. Proprietary 4-pin IP65 cabling simultaneously passes RDM, DMX data, and power. Adapters and cable extensions are available for data and power interconnections.



See available Adapter and Cable options under Accessory Items section.

Power

Fixtures require a 12-24v DC power supply. **Fixtures cannot be connected directly to mains voltage.** A maximum of 12 units can be connected to any single power supply.

For large installations, both the number of fixtures and the total length of cables can result in DC voltage drop issues. When more than 12 units are used, either divide system into multiple power/data runs or utilize power injection points with multiple power supplies. If unsure, consult a professional.



Disconnect from power mains before any service.

Do not apply power to fixture without first testing and verifying power source.

Do not use power supply if damaged or not connected with suitable earth ground.

Configuration Setup

RDM Data

All Fixture Settings and Menus are accessed through an RDM (Remote Device Management) capable controller or device. RDM is a bi-directional enhancement to standard DMX512 data. RDM allows for remote fixture discovery, addressing, individual fixture identification, complete menu access, and retrieving status information over traditional DMX networks.



All RDM menu updates are confirmed by the fixture briefly flashing the LED output.

RDM Considerations

An RDM capable controller or device must be used to change RDM settings. While traditional DMX512 fixtures can operate on DMX on the same control line, all other connected fixtures and devices must also be capable of passing bi-directional data when utilizing RDM. Up to a maximum of 32 connected fixtures can be discovered under RDM and individually accessed. Exceeding 32-fixtures can cause RDM and/or DMX data issues. Best DMX512 practices must be followed for maximum fixtures on any DMX data line or universe. While every effort is made to ensure compatibility, there may be issues between RDM controllers/programmers and equipment from different manufacturers. If unsure, consult a professional.

Fixture Settings

The chosen DMX personality sets the DMX channel layout or enables Standalone Mode.

- DMX (Full or Basic): DMX data controls the fixture subject to the channel layout using the chosen start address.
- Standalone (0-Channel) only requires power for operation. Powering on the fixture will automatically run the Standalone preset options stored in the fixture without any need for data.
- Fixtures configured for DMX or Standalone may be combined on the same cable run.

DMX

Standard DMX512 is used for control after initial RDM setup of DMX personality and start address.

1. **DMX Personality:** Choose either Basic or Full Channel Mode
2. **DMX Address:** Select a start address for fixture. Leave enough space to account for the Basic or Full channels needed by each fixture.
3. See Fixture Channel Chart for control options.

Standalone

After selecting “Standalone” for the DMX Personality choose whether the preset activates instantly or fades up.

Configuring Standalone Mode:

1. **DMX Personality:** 3. Standalone Mode (0-Channel)
2. **Standalone ON** selects preset start at power on, two options:
0 – Preset comes to full instantly.
1 – Preset ramps up softly with a fade.
3. For available RDM control options, reference Fixture Channel Assignments and values Chart

Fixture Parameter Options

Features across all units:

Device Label/Name
DMX Start Address
DMX Personality Channel Layout/Standalone
Lamp/Power On Mode
Factory Defaults
Device Reset

Standalone Functions: See DMX/RDM charts for channel value specifics to each fixture.

RDM Settings and Parameters

RDM settings and features may be presented or named differently by different controllers. Some names or labels maybe used to perform different functions than the ones it was intended for due to a lack of pertinent labels. The function table below is an example of typical settings.

RDM Options & Functions		
(LED Output Flash on change to signal acceptance)		
Fixture Function	Data Type	Value
Basic Info		
Device Label	Editable	<Spar Light XXXX> Can be edited for number, name or position of specific fixture
DMX Address	Settable	1 - 512
DMX Personality Modes	Selectable	1. DMX Basic Mode (#ch) (lowest channel mode)
		2. DMX Full Mode (#ch) (most channel control)
		3. Standalone Mode (0ch)
Standalone Mode Options		
Fixture Function	Data Type	Value
Manufacturer Settings		
Standalone On	Selectable	0 Start-0 Instantly jumps to set value on power-on
		1 FadeUp-1 Fades up to set value on power-on
Standalone R Channel - Red	Settable	0-255
Standalone G Channel - Green	Settable	0-255
Standalone B Channel - Blue	Settable	0-255
Standalone W Channel - White	Settable	0-255
Standalone CW Channel – Cool White	Settable	0-255
Standalone WW Channel – Warm White	Settable	0-255
Standalone UV Channel – UV	Settable	0-255
Standalone Master	Settable	0-255
Standalone Macro	Settable	0-255
Standalone Speed	Settable	0-255
Other RDM Options		
Fixture Function	Data Type	Value
Product Information		
Factory Defaults	Selectable	Restore Fixture to Factory Defaults
Power/Lamp		
Lamp On Mode – when DMX Lost	Selectable	Off Fixture drops output to “0” (off)
		DMX Fixture holds last DMX Data values
		ON Fixture goes to full - RDM Control Setting

Channel Assignments and Values - DMX/RDM

DL-SPAR18TC/B RGB					
Mode		Function	Value		Description
Basic 3ch	RDM** Full 6ch		Decimal	%	
1	1	Red LED	0 - 255	0 - 100	Intensity control of RED LED
2	2	Green LED	0 - 255	0 - 100	Intensity control of GREEN LED
3	3	Blue LED	0 - 255	0 - 100	Intensity control of BLUE LED
	4	Master Dimmer	0 - 255	0 - 100	Master Dimmer sets overall output of RGB
	5	Macro Function	0 - 20	0 - 7	No Macro Effect
			21 - 40	8 - 15	Strobe - RGB sets color
			41 - 60	16 - 23	Double Strobe – RGB + Master sets color
			61 - 80	24 - 31	Flame Flicker – RGB + Master sets color
			81 - 100	32 - 39	Power Surge – RGB + Master sets color
			101 - 120	40 - 47	Ember – RGB + Master sets color
			121 - 140	48 - 54	Pulse – RGB + Master sets color
			141 - 160	55 - 62	Blink – RGB + Master sets color
			161 - 180	63 - 70	RGB Wave rainbow rolling effect, Master sets level
			181 - 200	71 - 78	RGB Chase rainbow stepped effect, Master sets level
	201 - 255	79 - 100	No Macro Effect		
	6	Macro Speed	0 - 255	0 - 100	Sets Macro run speed

DL-SPAR18QW/B RGBW					
Mode		Function	Value		Description
Basic 4ch	RDM** Full 7ch		Decimal	%	
1	1	Red LED	0 - 255	0 - 100	Intensity control of RED LED
2	2	Green LED	0 - 255	0 - 100	Intensity control of GREEN LED
3	3	Blue LED	0 - 255	0 - 100	Intensity control of BLUE LED
4	4	White LED	0 - 255	0 - 100	Intensity control of WHITE LED
	5	Master Dimmer	0 - 255	0 - 100	Master Dimmer sets overall output of RGBW
	6	Macro Function	0 - 20	0 - 7	No Macro Effect
			21 - 40	8 - 15	Strobe - RGBW sets color
			41 - 60	16 - 23	Double Strobe – RGBW + Master sets color
			61 - 80	24 - 31	Flame Flicker – RGBW + Master sets color
			81 - 100	32 - 39	Power Surge – RGBW + Master sets color
			101 - 120	40 - 47	Ember – RGBW + Master sets color
			121 - 140	48 - 54	Pulse – RGBW + Master sets color
			141 - 160	55 - 62	Blink – RGBW + Master sets color
			161 - 180	63 - 70	RGBW Wave rainbow rolling effect, Master sets level
			181 - 200	71 - 78	RGBW Chase rainbow stepped effect, Master sets level
	201 - 255	79 - 100	No Macro Effect		
	7	Macro Speed	0 - 255	0 - 100	Sets Macro run speed

**Standalone mode controls match DMX Full mode options

DL-SPAR18VW/B CW/WW

Mode		Function	Value		Description
Basic 2ch	RDM** Full 5ch		Decimal	%	
1	1	Cool White LED	0 - 255	0 - 100	Intensity control of Cool White LED
2	2	Warm White LED	0 - 255	0 - 100	Intensity control of Warm White LED
	3	Master Dimmer	0 - 255	0 - 100	Master sets overall output CW/WW
	4	Macro Function	0 - 20	0 - 7	No Macro Effect
			21 - 40	8 - 15	Strobe - RGB sets color
			41 - 60	16 - 23	Double Strobe - CW/WW + Master sets color
			61 - 80	24 - 31	Flame Flicker - CW/WW + Master sets color
			81 - 100	32 - 39	Power Surge - CW/WW + Master sets color
			101 - 120	40 - 47	Ember - CW/WW + Master sets color
			121 - 140	48 - 54	Pulse - CW/WW + Master sets color
			141 - 160	55 - 62	Blink - CW/WW + Master sets color
			161 - 180	63 - 70	CW/WW Wave rolling effect, Master sets level
			181 - 200	71 - 78	CW/WW Chase stepped effect, Master sets level
	201 - 255	79 - 100	No Macro Effect		
	5	Macro Speed	0 - 255	0 - 100	Sets Macro run speed

DL-SPAR17UV/B UV

Mode		Function	Value		Description
Basic 1ch	RDM** Full 3ch		Decimal	%	
1	1	UV LED	0 - 255	0 - 100	Intensity control of UV LED
	2	Macro Function	0 - 20	0 - 7	No Macro Effect
			21 - 40	8 - 15	Strobe - UV sets level
			41 - 60	16 - 23	Double Strobe - UV sets level
			61 - 80	24 - 31	Flame Flicker - UV sets level
			81 - 100	32 - 39	Power Surge - UV sets level
			101 - 120	40 - 47	Ember - UV sets level
			121 - 140	48 - 54	Pulse - UV sets level
			141 - 160	56 - 62	Blink - UV sets level
	161 - 255	63 - 100	No Macro Effect		
	3	Macro Speed	0 - 255	0 - 100	Sets Macro run speed

**Standalone mode controls match DMX Full mode options

Maintenance



Make sure fixture is disconnected from power mains before any service.

Weekly operating hours and environmental conditions will establish how often the fixtures need cleaning. Fixtures should be cleaned and inspected at least once a month to maintain optimum performance. Accumulation of dust or residues increase heat buildup, leading to malfunctions, overheating and reduction in maximum light output, reduced fixture life and overall performance. Before conducting any maintenance, disconnect fixture from power mains.

- 1) Disconnect fixture from power.
- 2) Use a vacuum with a soft brush to remove dust collected on external components. If using an air compressor, use low pressures and extreme care to prevent damaging any parts.
- 4) Clean all optical elements when the fixture is cold. Use a soft lint free cotton cloth or tissue and cleaner safe for plastics.
- 5) Check that lens cap is secure.
- 6) Inspect clamps/mounting hardware and safety cables to ensure fixture is secure and safe.

Troubleshooting

Diagnostic technique for DMX issues: Set suspect fixture's Start Address the same as a correctly functioning fixture. If both units then function correctly, issue is in programming.

Symptom	Possible Cause / Solution
No Power	No power to supply or bad power supply.
	Check all cables and connections are secure.
	Overloaded power supply, voltage at fixture is too low.
	Ensure maximum of 12 units on any single daisy chain power supply run.
DMX Erratic / No response / Flickering	Check cable connections and integrity.
	Check Start Address and DMX Personality and for possible channel overlaps.
	Check voltage at fixture, must not be lower than 11v DC.
	Check Data Terminator.
	Check for incompatible devices or fixtures in line.
	Check for bad DMX Controller.
RDM Erratic / no response	Check cable connections and integrity.
	Check for incompatible device or fixtures in line.
	Check for Maximum of 32 fixtures on an RDM daisy chain data link/line.
	Cycle Power and Retest
No Output or Image Partially Obstructed	Check Lens, Cover, and Beam Accessories.

DMX-512 Background

DMX-512 is a digital data transmission standard developed by the United States Institute for Theater Technology (USITT). It is designed to enable control of lighting equipment. DMX deals solely with the formatting of data for transmission and does not dictate how the data is created or used.

Under DMX, signals are transmitted in much the same way a computer modem transmits data. The Data, divided into channels, is "Framed" using a start bit, high (1), eight data bits and finally, two stop bits, both high (1). DMX uses no parity to check the integrity of the signal. Instead, DMX relies on the ultra low probability of an error occurring in the same place when the data is resent. The rate at which data is sent is fixed at 250k bps, almost four and a half times faster than a 56k modem. This speed allows all data on a DMX chain to be updated more than 44 times every second.

The transmitted data follows a specific format. DMX allows for 512 channels each with eight data bits, giving each channel the possibility of 256 values. When a data "Packet" is sent, all channels are transmitted one after another. Even if the data on a specific channel has not been changed, it must be sent. In a packet, a "start code" of all zeros is sent before the data to identify the signal as a Standard DMX transmission. This start code is transparent to the user and is handled by the controller.

The physical signals are transmitted using a twisted pair of wires and a common shield, a configuration called Balanced. The controller and all receiving equipment are connected using a "Daisy Chain" connection. The signal is jumped from the controller to a piece of DMX equipment. From there, the signal is jumped to the next piece of equipment and so on until the last piece of equipment is connected. No branches are allowed and the signal does not come back to the controller. The final piece of equipment will have only one cable connection. As a result, all equipment connected to the chain will see exactly the same signal whether it is first or last. When connecting equipment, no particular attention needs to be paid to the order in which the equipment is connected. Depending on the conditions and equipment, a line terminator may be required. If there is any question, in most circumstances the addition of a terminator will not degrade the signal. To make a terminator, attach a 120-ohm resistor between the Signal Data Negative and Signal Data Positive pins of a connector in the last piece of equipment in the chain.

The DMX Standard uses 5 pin XLR connectors. However, it is common to see fixtures with 3 pin XLR connectors as these types of balanced or "Lo-Z" cables are common in the audio industry. In either case, pin numbers are the same and carry the same signals.

Pin	Connection
1	Common (Shield)
2	Data Negative (S- or Cold)
3	Data Positive (S+ or Hot)
4	n/c (not used)
5	n/c (not used)

Accessory Items (sold separately)

Product Code	Description
Lenses	
ZOLE1040	Lens LED 8°, Diameter 37mm for Spar Light
ZOLE1041	Lens LED 15°, Diameter 37mm for Spar Light *Included with fixture
ZOLE1042	Lens LED 25°, Diameter 37mm for Spar Light *Included with fixture
ZOLE1045	Lens LED 45°, Diameter 37mm for Spar Light
ZOLE1046	Lens LED 60°, Diameter 37mm for Spar Light
Top Hat Snoot	
TA-FHATSPAR/B	Full top hat snoots are used to reduce glare and light spill. This snoot is specifically designed to mount on the front of the Spar Light. Size: Outside diameter 58mm x 83mm Long • Mounts using 2x 2.5mm set screws included • Color: Black • Material: Aluminum
Honeycomb	
TA-HONCOMB/SPAR	Honeycomb Louver 1.5mm Black for SPAR Light - use to minimize side glare • Color: Black • Material: Aluminum
Ground Stake	
CL-GSSTAKE1	Ground Stake accessory for mounting Spar Light Small Par LEDs - 8.5" length x 2.75" diameter • Weight: 0.07 kgs/0.15 lbs • Color: Black • Material: Aluminum
4-Pin Adaptor Cables - Black	
DA-4PDI5	E Initial Data Power 4-Pin female to DMX Data 5-Pin Male XLR and 2-Pin Power In • Includes an End of line Terminator • Cable length: 12" wide x 6.5" high • Weight: 0.19 lbs
DA-4PDI3	E Initial Data Power 4-Pin female to DMX Data 3-Pin Male XLR and 2-Pin Power In • Includes an End of line Terminator • Cable length: 12" wide x 6.5" high • Weight: 0.19 lbs
DA-4PPIDC	B 2-Pin Power in used for DMX 4 pin series lights to inject power into T's. Provides power in connector with 20 inch to standard DC 5.5mm round barrel connector. 2-Pin IP female cable to DC 5.5mm x 2.1mm Female barrel connector • Cable length: 20" long x 3/4" diameter • Weight: 0.4 lbs
DA-4PPI	B Power In cable 2-Pin female to 2 meter tail with leads • Cable length: 78" long x 3/4" diameter • Weight: 0.525 lbs
DA-4PDPO5	4-Pin male input • Outputs: DMX Data on 5-Pin Female XLR and Power on barrel DC Male 5.5mm x 2.1mm • Cable Length: 12" wide x 6.5" high • Weight: 0.19 lbs
DA-4PPODC	4-Pin Power in to output DC 5.5mm barrel male connector. Provides power out from end of a 4P cable run, or out of last light. 4-Pin male with 50cm cable to DC 5.5mm male connector • Cable length: 19 inches • Weight: 0.09 lbs
DA-4PPT	C Inline power injector, with 2-Pin male to 4-Pin male in and out to 4-Pin female • Cable length: 12" wide x 6.5" high • Weight: 0.19 lbs
DA-4PT	4-Pin connectors from 1 male to 2 females Split T • Cable length: 12" wide x 6.5" high • Weight: 0.131 lbs.
4 Pin Male to Female Extension Cables – Black	
DA-4PE1/2	D 0.5 meter length. • Cable length: 19.4" long x 3/4" diameter • Weight: 0.11 lbs
DA-4PE1	D 1 meter length. • Cable length: 40" long x 3/4" diameter • Weight: 0.2 lbs
DA-4PE2	D 2 meter length. • Cable length: 79" long x 3/4" diameter • Weight: 0.4 lbs
DA-4PE3	D 3 meter length. • Cable length: 118" long x 3/4" diameter • Weight: 0.6 lbs
DA-4PE5	D 5 meter length. • Cable length: 197" long x 3/4" diameter • Weight: 1 lb
DA-4PE10	D 10 meter length. • Cable length: 393.7" long x 3/4" diameter • Weight: 2 lbs

LED Lighting Regulated Power Supplies	
DA-PSU12120IDC	12V 120W Supply for up to 6 Spar lights, with 50 ft cable maximum • Certifications: UL E480146
DA-PSU20200IDC	20V 200W Supply for up to 12 Spar lights, with 100 ft cable maximum • Certifications: CE, ETL 5012405
DA-PSU24240IDC	24V 240W Supply for up to 12 Spar lights, with 125 ft cable maximum • Certifications: CE



10900 Palmbay Drive • Orlando, FL 32824 U.S.A.
www.techni-lux.com