

These instructions ensure the correct functioning of your **Vari-Color**. They are therefore to be considered an integral part of it. It is very important to read them carefully.

## 1. UNPACKING

Open the cardboard box, take out the lantern and put it on a horizontal surface. In case of damage, apply to the forwarder.

## 2. SAFETY NORMS

- This lantern is intended only for indoor usage.
- Maximum ambient temperature: 35° C.
- Minimum distance from inflammable surface: 1.0 m.
- Make sure that the plug bears the requested rated load (see technical data).
- Replacement of any part of the Projector must be carried out exclusively by professional personnel using components identical or compatible with those originally fitted.
- Before any (maintenance, cleaning, etc.) action, switch off the power supply.
- In case of even light damage, replace the lamps.
- When replacing the lamps, make sure they are cold before the substitution.
- Never use the lantern if it is not correctly earthed.
- Always use a safety cable.

## 3. INSTALLATION

This lantern can be fixed in any position within the limits described in picture 1.

Picture 1

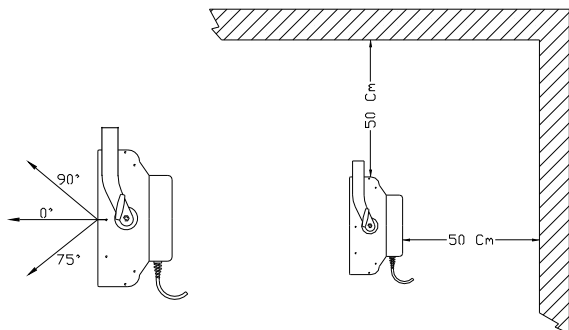

Fix the projector in a well-ventilated position. In case of positioning the projector in a corner, keep the distances as shown in picture 1. We suggest to use an M10 screws with nut and washer, making sure of the stability of the anchor point. N.B. according to the international norms EN 60598-2-17 it is compulsory the usage of a safety cable in order to fix the lantern to a secondary point. For this purpose there is an appropriate hole in the stirrup.

## 4. ELECTRICAL CONNECTION

This lantern must be powered according to the voltage and frequency showed on its rear part (220V and 50Hz) (110V 50/60Hz). Connect the power cable to the socket. We suggest to connect each lantern to its own switch so that they can be individually switched on with a remote control.

## 5. CONTROL SIGNAL CONNECTION

The connection of a lantern to a DMX512 control desk and of a lantern to another lantern must be made with a shielded bipolar cable and connectors like Cannon 5 Pin XLR.

Picture 2

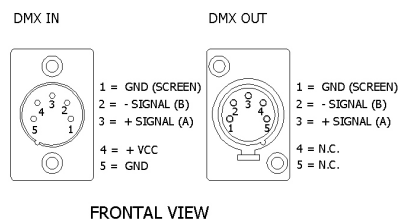

It is important that the wires do not make contact with each other or have contact with the covering of the plug. **IMPORTANT:** In order to avoid malfunctions and interferences, insert the terminal plug in the last lantern of the DMX512 line, with a 120 ohm resistor between terminals 2 and 3. **N.B.** Vari -Color is fitted with a power output for the VR2 remote control or for the Music Box: this power supply must be taken from poles 4 and 5 of connector XLR male (DMX input, picture 2).

## 6. PERIODICAL MAINTENANCE

Before any action switch off the power supply. We suggest to clean the filters and parabolic reflectors at least once a month and to replace the lamp even in case of light damage. Check the cooling fan air intakes clearing them from incidental obstructions.

## 7. LAMP REPLACEMENT

It is strongly recommended the usage of 500W lamps if the Vari-Color has to be installed in commercial centres, shops, or wherever a long-lasting performance is required. (see technical data).

To replace possible damaged lamps, see pictures at page 2:

## 8. FUSE REPLACEMENT

To replace possible damaged fuses, act as follows:

- Disconnect the lantern from the power supply
- Take out the rear master cover unscrewing the 4 M4 fixing screws.
- Find out the damaged fuse according to the colour connected with it (see picture 3).
- Replace the damaged fuse with a new one with the same characteristics.
- Mount back the rear master cover reassembling the 4 fixing M4 screws.
- Connect back the lantern to the power supply.

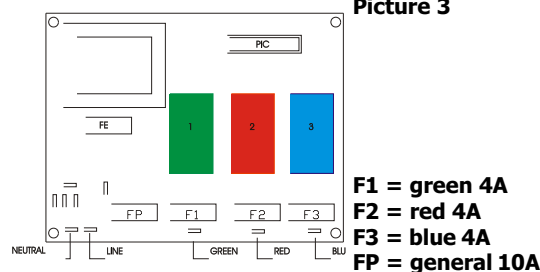

Picture 3

## 9. POSITIONING

In order to position the lantern, unscrew the sidehand wheel and the M10 fixing screw and point the light beam in the middle of the show.

**IMPORTANT:** never carry out this operation at its maximum power, act using the 50% of the maximum intensity in order to not damage the lamps.

## 10. DIMENSIONS

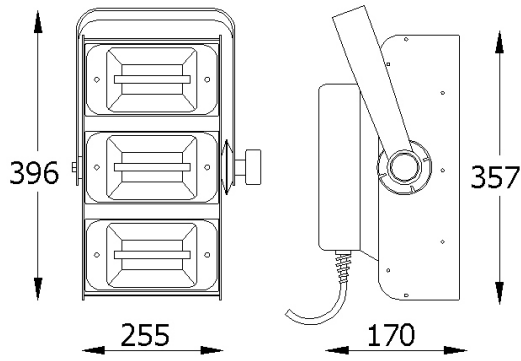

## 11. TECHNICAL DATA

This projector is **PATENTED: RM97A000062.**

Voltage: 110V

Frequency: 50/60 Hz

Current: 9A

Lamp: 3 x EME 800W 220V (lamp life: 150h)

3 x 500W 220V (lamp life: 2000h)

3 x 300W 220V (lamp life: 2000h)

flux: 23.000 lm

colour temperature: 3200 K

Lamp holder: 3 x R7s

Power unit: max 2500 W

Temperature: max 90 °C

Protection rate: IP20

## 12. ACCESSORIES



4-leaf barndoor

cod. 070006



DMC 160 16Ch DMX controller

cod. 1801



Dichroic filter blue 137X100  
red  
green

cod. FD0061  
cod. FD0060  
cod. FD0062

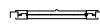

Lamp: EME 800 W 220V(150 h)  
500 W 220V(2000 h)  
300 W 220V(2000 h)

cod. 10145  
cod. 10530  
cod. 10525



Lamp holder: R7S

cod. 001090



30X6 Hook damp

cod. 4009



Ø 3mm steel safety bond

cod. 4012



Weight Kg 6,8

## LAMP CHANGING

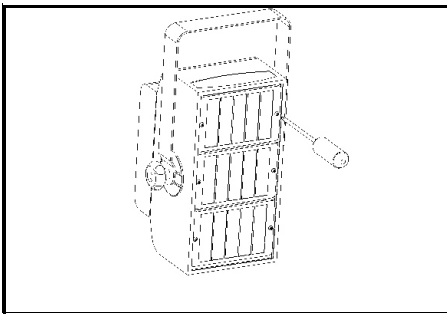

**ATTENTION: REMOVE SUPPLY BEFORE OPENING THE LANTERN**

Un mount the colour filter holder.

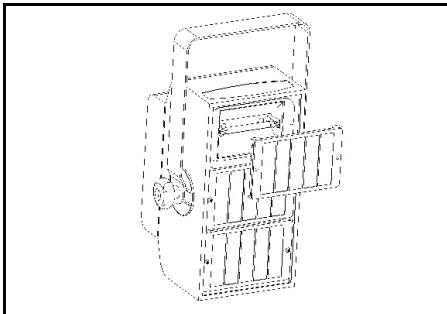

Carefully remove the colour filter holder from its place.

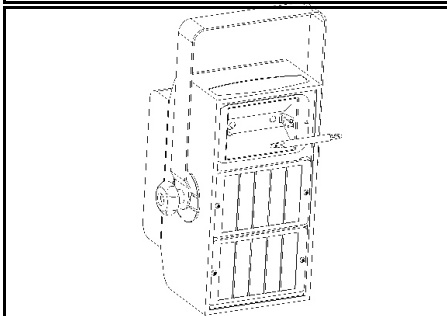

Remove the lamp.  
Reassemble the parts following the instructions in reverse order.

### 13. CODING AND FUNCTIONING OPTIONS

Each **Vari-Color** takes up to 2 or 3 control channels (see table C).

In order to address correctly the control signals, it is necessary to follow the steps below:

- 1 Connect the control signal and switch on the lantern (with no signal a red led will be on): the DMX channel is displayed.
- 2 Press UP and DOWN buttons to set the number of the chosen channel (see table A and B).
- 3 Press ENTER to save the chosen channel.
- 4 Press and hold ENTER for more than 8 seconds to set the functioning options (see table C); F1 L or H is displayed.
- 5 Press UP and DOWN to select (H) or cancel (L) the option you want.
- 6 Press and hold ENTER for more than 8 seconds to exit.

**Table A- Functioning with 2 DMX channels**

Proiettore 1 (canali 1 – 2)	Numero da selezionare 001
Proiettore 2 (canali 3 – 4)	Numero da selezionare 003
Proiettore 3 (canali 5 – 6)	Numero da selezionare 005
Proiettore 4 (canali 7 – 8)	Numero da selezionare 007

**Table B- Functioning with 3 DMX channels**

Proiettore 1 (canali 1 – 3)	Numero da selezionare 001
Proiettore 2 (canali 4 – 6)	Numero da selezionare 004
Proiettore 3 (canali 7 – 9)	Numero da selezionare 007
Proiettore 4 (canali 10 – 12)	Numero da selezionare 010

**Table C- Functioning options**

Option	function
1	F1L Cancel built in games function
	F1H Select built in games function
2	F2L Cancel sequential colours function
	F2H Select sequential colours function
3	F3L Select 3 channels functioning
	F3H Select 2 channels functioning
4	F4L Empty
	F4H Empty
5	F5L Logarithmic dimming level
	F5H Linear dimming level
6	F6L Select 50 Hz Power input
	F6H Select 60 Hz Power input
7	F7L Standard
	F7H Empty
8	F8L Empty
	F8H Empty

**Table D- Functions descriptions**

F1	No DMX in, 4 automatic built in games selectable at 4 different speeds. To select the game, use the arrows up & down like selecting DMX channel (see page 4).
F2	Controlled by DMX input. The first DMX channels controls the speed of the colour changing. The second channel controls the dimming level.
F3L	The 3 colours are controlled by 3 DMX channels.
F3H	The first DMX channels controls the colour changing, the second one controls the dimming level.

### 14. GAMES

To run the built-in games, act as follows :

- 1 Select F1 function as described in paragraph 13 and table C.
- 2 Use UP and DOWN keys like in DMX addressing.
- 3 press ENTER

**Table E- Games description**

GAMES	FUNCTIONS
Game 1	White, Blue, Green, Yellow, Orange, Red, Violet, Red, Orange, Yellow, Green, Blue, White + Cross Fading Colour Mix Sequence
	001 Very Slow
	002 Slow
	003 Normal
Game 2	Blue + Black Out Fading Sequence
	004 Fast
	005 Very Slow
	006 Slow
Game 3	Red + Black Out Fading Sequence
	007 Normal
	008 Fast
	009 Very Slow
Game 4	Green + Black Out Fading Sequence
	010 Slow
	011 Normal
	012 Fast
	013 Very Slow
	014 Slow
	015 Normal
	016 Fast

### 15. Master/Slave functioning

It is possible to control different projectors by the stand alone programs of the MASTER projector.

To do this set one projector on the stand alone mode (see table A at page 1) and this will be the MASTER one.

Set the other projectors (SLAVE) on DMX channel 001 and on the 3 channels functioning (F3 L, see table A).

<b>MASTER</b> projector: F1H
---------------------------------

<b>SLAVE</b> projector: F1L F3L
---------------------------------------