



# ALTMAN

architectural lighting catalog



The Children's Museum of Indianapolis, Indianapolis, IN  
Artwork by Dale Chihuly

# Focus on LIGHTING

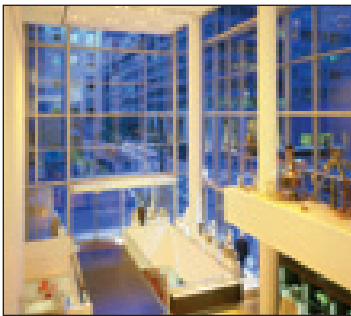

Lighting for the retail environment is a key in helping a store enhance the retail experience in an effort to draw customers back to their stores.

Altman Lighting is proud of its history in support of lighting designers and their art. In the past, architectural lighting was dictated mainly by the beam spread of the lamp; if you wanted to manipulate the light, you swapped out a spot for a flood lamp. Today, luminaire designs and lighting control systems allow the designer more options to control the visitor's experience in the created environment.

At Altman we have taken our wealth of experience working in other fields and applied them to the task of architectural lighting. If you need track lighting systems with innovative control features, you will find them here. No matter if you are working indoors or out, we have luminaires for a wide variety of applications. We have systems that allow you to mix and match quartz, CDM, or LED luminaires on the same track as well as the same circuit. With remote dimming and control capabilities, you now can worry about where the light goes and rest assured that the control of those lights is the easy part of the system.

At Altman we have taken our knowledge of optics and engineered exterior lighting products to allow you more control than most thought possible. You can accurately highlight exterior architectural features or wash them in color, never having to worry about the weather.

At Altman we are exploring ways of using LEDs in architectural luminaires in new and innovative ways. Now you can add some color to a track system as well as have flexible control of the beam spread with an LED color mixing luminaire that is designed to stand up to the weather and continue providing colorful light night after night.



For over 55 years, Altman has supported designers by giving them the means to express their vision in a realized form. We have a long track record of taking the wildest flights of fancy and producing everything from one-offs to complete product lines. A designed mix of our stock product with our custom work helps the designer shape the environment they desire.

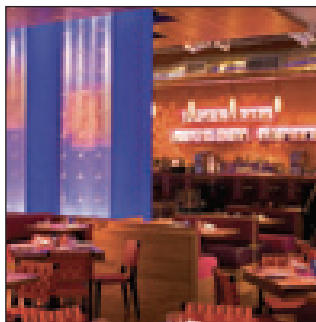

Strong interior design is made even better when it is supported by complementary lighting. It is the right equipment solutions that reveal the design, whether the architectural concept emphasizes functionality or form, often the lighting must accomplish both.

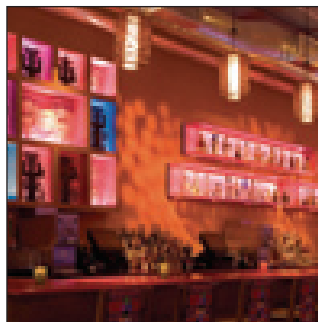

Design is often enhanced by use of lighting solely for the sake of decorative reasons, with no practical function. When such lighting is mixed with strong ambient lighting the balance established is felt by the patron.

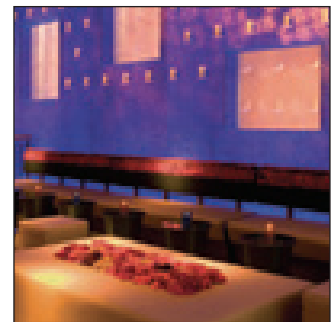

Whether you are looking for an overall ambient lighting design, or one that dramatically highlights the space; no matter if it is form or function, we can provide you with the proper tools to make your design work.



Light can help define a space as well as set the mood. By placing the light in just the right place; shaping the beam of light — controlling the light — you can highlight that architectural feature, give focus and direct the viewer's eye where you want it to go. With the right choice of color in the light you can create a positive environment as well as influence a person's mood.

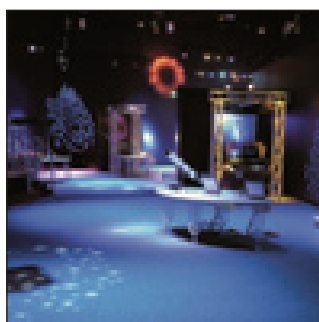

The ability to control the environment with lighting requires the designer to establish both the required ambient light needed as well as the desired shifts in mood that the viewer should be moved through in the course of the experience.

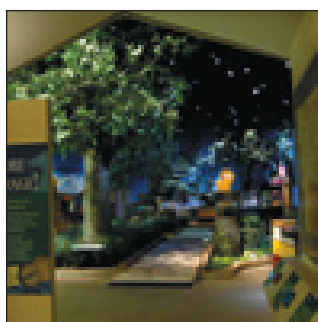

Carefully chosen and focused light brings the exhibits out of the darkness to direct attention towards the essential elements. The lighting draws the viewer through the experience by specific use of both focus and color.

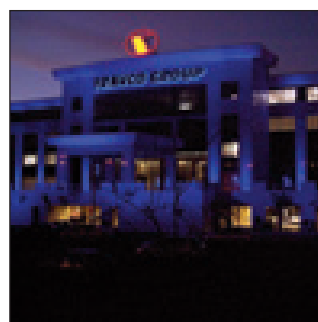

We have worked with lighting designers from all backgrounds and experiences—architectural, theatrical, television and film, concerts, theme parks, and museums. This knowledge helps us improve our products to offer cost-effective solutions.

(top) Museum of the City of New York, Lighting Design by Available Light  
 (left) Science Center of Iowa, Lighting Design by Available Light  
 (center) North Carolina Museum of Natural Sciences, Lighting Design by Available Light  
 (right) Travco Group Egypt, Lighting Design by Hatem Habashi

# Smart-Track® Lighting System

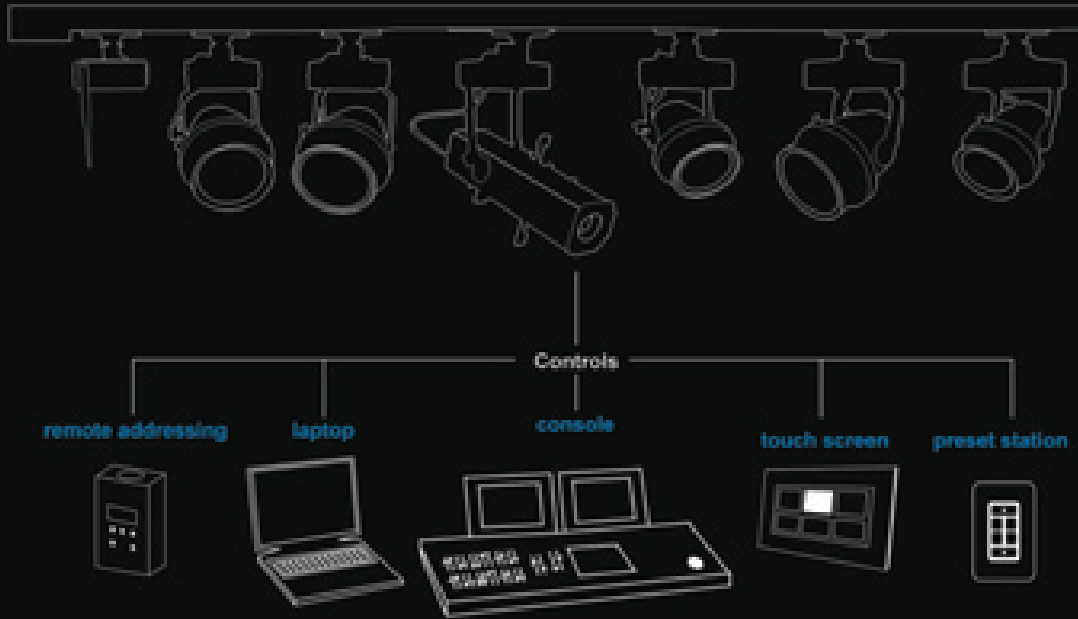



Altman Architectural/ Theatrical Smart-Track Lighting System is a revolutionary way to bring digital control signals to addressable architectural/ theatrical luminaires without the need for dimmer packs and bulky cable runs. Altman Smart-Track is easy to lay out, install, and offers you the opportunity to easily create and activate new lighting scenes time after time, all at a cost-effective price. The Smart-Track Lighting System works best with Altman Smart IQseries luminaires. This series includes quartz, CDM, and LED light sources with built-in dimming and control. With Smart-Track, you can dim the quartz lamps; switch the CDM lamps on and off; as well as dim and color mix LED sources. The unique features of Altman Smart-Track system make it the ideal solution for many applications. The system is suitable for retail stores, museums, churches, restaurants, clubs, and so much more. The range of applications for Altman Smart-Track is as varied as the looks the system makes possible.

## Focus on SMART-TRACK

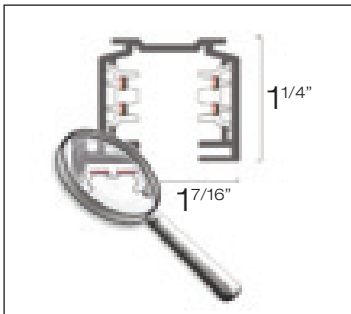

Smart-Track is a comprehensive system of components that offers innovative solutions for transporting control signals as well as power to individual luminaires. Whether using simple architectural control stations; a laptop; or a DMX-based theatrical lighting console, you are in control with Smart-Track.

This heavy-duty extruded aluminum track is ideal for demanding applications where a low-profile look is desired but numerous luminaires are needed.



For total flexibility, you can choose your protocol. Smart-Track is compatible with DMX and RDM (Remote Device Management). It also can be integrated into existing systems to easily expand to a new design. By including the digital control signal in the track, the Smart-Track system allows dimming, switching, and effects to be obtained when using Altman Smart IQseries of luminaires. With quartz and CDM luminaires with on-board dimming or control, as well as Altman Spectraseries LED architectural luminaires for color mixing, the possibilities are endless.

(top) Cross Section of Smart Track detailing the 2 Circuits with the DMX /data bus for digital control.

The Altman Smart IQseries luminaires retain their identity and programming, even when moved to a new location. The designer can individually control each luminaire hung on the track system.

(bottom) Example of a Smart Fixture; SS-IQ38Y with on-board DMX interface and power supply.

Automated luminaires as well as DMX accessories may be controlled all from the Smart-Track system as well by using the DMX outlet adapter to break DMX out of the track. Maximum control and reduced energy costs make Altman Smart-Track lighting system the innovative solution for any application.



The Smart-Track Lighting System™ now offers wireless DMX control via Altman Lighting's Smart Receiver & a SHoW DMX™ 5600 transmitter.



**Smart Track: *The possibilities are endless...***

# Track Lighting

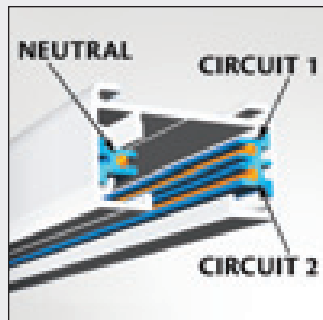

**Global trac® eco | Catalog number : ASL-E1, ASL-E2**

When you need a compact solution, this track series from Nordic Aluminum fills this requirement. Depending upon the model, you can have one or two 20-amp circuits so that one or two groups of luminaires can be operated on this track.

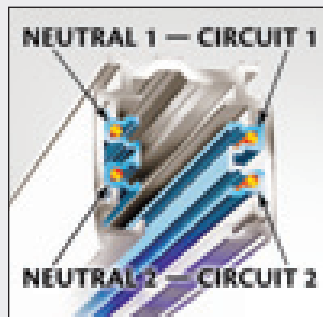

**Global trac® tek | Catalog number : ASL-2**

When you need dimming with your track lighting, this system gives you a separate neutral grounding conduit for each circuit. This guaranteed circuit isolation eliminates cross-circuit interference, giving you the best results when operating two separate groups of luminaires on the same track. Two neutral conductors means twice the power-handling capabilities.

6

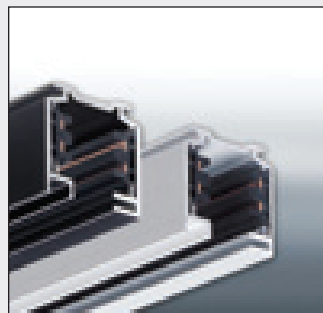

**Eutrac 2 Circuit Standard | Catalog Number: ASL-230\***

The 5 conductor (2 live / 2 neutral / 1 ground) surface track consists of an extruded aluminum profile which also functions as ground and 2 inserted plastic profiles carrying 4 embedded 12 gauge copper conductors. Any given profile can be easily cut to length on site. It is not necessary to cut back or bend back the conductors. The track has pre-punched holes for mounting every 8" on center.



How you install and control your luminaires is just as important as the light they produce. Altman offers a track for a wide range of design needs. From a single circuit through three circuit track with control functions, you will find the right combination of capabilities and cost-effectiveness. These tracks and accessories are from Nordic Aluminum. These track lighting products feature suspension rail, mounting holes, conductor mounts, and alignment grooves that are integrated, providing strength and easy installation. These tracks support one, two, and three 20-amp circuits per track depending on model. The tracks are made of lightweight extruded aluminum and are available in black, white, or natural stainless aluminum finishes. The tracks are available in nominal lengths of 4', 8', 12' (1.2 m, 2.4 m, 3.7 m).

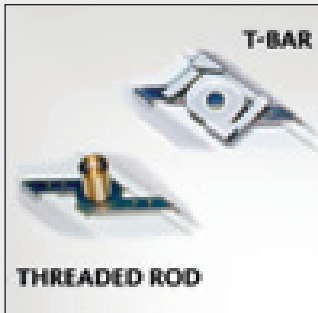

#### Mounting Methods

In addition to standard mounting hardware, Altman offers components for quick installation. The easy-to-use Twist-Lock Mounting Clips (for one and two-circuit *eco*) and track Mounting Clips (for 3-circuit *pro* and 2-circuit *tek*) are available in compatible finishes.



#### Suspension Methods

Stem kits allow you to hang track below the mounting surface. Stem lengths of 12", 18", 24", and 48". (30.5, 45.7, 61.0, and 121.9 cm) are available in compatible finishes.



#### Connectors

Use these components to create both conventional and non-grid layouts. Track lengths can also be linked. Conventional connectors work linearly or at right angles; for acute and oblique angles, use the Flexible Connector with accordion-fold sleeve for 1- and 2-circuit *eco*, and the jointed Adjustable Connector for 2-circuit *tek* and 3-circuit *pro*. In addition, the Conduit End Feed allows for connections around obstacles. Compatible finishes are available.

# IQseries CDM



## **IQ20 CDM | Catalog number : IQ20C**

This compact IQseries luminaire is designed for medium throws and accepts 39-watt CDM PAR20 lamps. At a distance of 20' (6.1m), the IQ20 CDM typically produces a pool of light 3' 6" (1.1 m) in diameter with a spot lamp, and 10' 6" (3.2 m) in diameter with a flood lamp. This luminaire uses 3"-diameter accessories.

- Lamp type : CDM PAR20
- Wattages : 39
- Voltages : 120, 240, & 277
- Avg. lamp hours : 9,000
- Dimensions (in) : 6.125 W x 9.875 H x 4.75 D
- Dimensions (Cm) : 15.56 W x 25.08 H x 12.06 D
- Weight : 5 lb / 2.3 kg



## **IQ30 CDM | Catalog number : IQ30C**

The PAR30 IQseries CDM luminaire accepts standard 39- and 70-watt CDM lamps. At a distance of 20' (6.1 m), the IQ30 CDM typically produces a pool of light 5' 2" (1.6 m) in diameter with a spot lamp, and a 10' 8" pool (3.3 m) in diameter with a flood lamp. This luminaire uses 3-3/4"-diameter accessories.

- Lamp type : CDM PAR30
- Wattages : 39 & 70
- Voltages : 120, 240, & 277
- Avg. lamp hours : 10,000
- Dimensions (in) : 6.125 W x 11.25 H x 5.25 D
- Dimensions (cm) : 15.56 W x 28.57 H x 13.33 D
- Weight : 6 lb / 2.7 kg



## **IQ36 CDM | Catalog number : IQ36C**

The IQ36 CDM accepts 38- and 70-watt CDM-R111 lamps, which make it ideal for accent and decorative lighting in retail applications. The CDM-R111 lamp for use in this luminaire is available in the following beam spreads : 10° Spot, 24° Narrow Flood and 40° Flood. This luminaire uses 3-3/4"-diameter accessories. Shown with optional barn doors.

- Lamp type : CDM R11
- Wattages : 38 & 70
- Voltages : 120, 240, & 277
- Avg. lamp hours : 9,000
- Dimensions (in) : 6.125 W x 11.25 H x 5.25 D
- Dimensions (cm) : 15.56 W x 28.57 H x 13.33 D
- Weight : 6 lb / 2.7 kg

Altman IQseries™ CDM is a range of PAR luminaires that deliver style, efficiency, and versatility. With their lightweight spun and extruded aluminum construction the rugged IQseries CDM adapts easily to your needs. Features include tool-free lamp access, vertical tilt lock with degree markings, and 370° horizontal rotation. IQseries CDM units are designed for use with ceramic discharge metal halide (CDM) lamps, which are highly efficient, with long life and a high color rendering index. The IQseries CDM is an ideal choice for all retail, display, exhibit, and residential applications. The units in the IQseries CDM have a durable powder coated finish and are available in black, white, or silver. Custom colors are also available. Mounting options include various track adapters, canopy, Unistrut®, stem, or pipe clamps. Numerous accessory options are available.



**IQ38 CDM | Catalog number : IQ38C**

The IQ38 CDM accepts standard 39-, 70- and 100-watt CDM PAR38 and PAR30 lamps. At a distance of 20' (6.1 m), this luminaire typically produces a pool of light 6' 6" (2.0 m) in diameter with a spot lamp and 13.5' (4.1 m) in diameter with a flood lamp. This luminaire uses 4-11/16"-diameter accessories.

- Lamp type : CDM PAR38, PAR30
- Wattages : 39, 70, & 100
- Voltages : 120, 240, & 277
- Avg. lamp hours : 10,000
- Dimensions (in) : 6.125 W x 10.5 H x 5.125 D
- Dimensions (cm) : 156 W x 268 H x 129 D
- Weight : 5 lb / 2.3 kg



**IQ38 CDM with Interchangeable Reflector  
Catalog number : IQ38C-T6**

Change reflectors with this PAR38 luminaire and create narrow-, medium-, and wide-angle beams without changing the CDM T6 lamp. The reflectors are available in 12°, 25°, and 50° spreads. This luminaire uses 4-11/16" diameter accessories.

- Lamp type : CDM T6
- Wattages : 39, 70, & 150
- Voltages : 120, 240, 277
- Avg. lamp hours : 12,000
- Dimensions (in) : 6.06 W x 12.32 H x 7.06 D
- Dimensions (cm) : 15.39 W x 31.3 H x 17.93 D
- Weight : 5 lb / 2.3 kg



**IQ64 CDM | Catalog number : IQ64C**

The IQ64 CDM accepts standard 150-watt PAR64 CDM lamps. At a distance of 40' (122.2 m), this luminaire typically produces a pool of light 6' 2" (1.9 m) in diameter with a spot lamp and a pool 25' 2" (7.7 m) in diameter with a flood lamp. This luminaire uses 7-7/16"-diameter accessories.

- Lamp type : CMH150/PAR64
- Wattages : 150
- Voltages : 120, 240, & 277
- Avg. lamp hours : 8,000
- Dimensions (in) : 8.62 W x 13.62 H x 8.62 D
- Dimensions (cm) : 21.9 W x 34.6 H x 21.9 D
- Weight : 8 lb / 3.6 kg

# IQseries Quartz



## **IQ20 MR16** | Catalog number : **IQ20MR16**

For use with 20- to 75-watt MR16 and standard 3.25" (8.3 cm) accessories. From 15' (4.6 m), this luminaire can produce a pool of light 4' 5" to 12' (1.3 to 3.7 m) in diameter. This luminaire uses 3"-diameter accessories.

- Lamp type : MR16
- Wattages : 20, 37, 50, & 75
- Voltages : 120, 240, & 277
- Avg. lamp hours : 2,000
- Dimensions (in) : 4.88 W x 7.75 H x 4.75 D
- Dimensions (cm) : 12.4 W x 19.7 H x 12.06 D
- Weight : 1.5 lb / .7 kg



## **IQ20 Quartz** | Catalog number : **IQ20**

For use with PAR20/PAR16 lamps. From 10' (3.0 m), can produce a pool of light 2' 1" (64 cm) across with a spot lamp. This luminaire uses 3"-diameter accessories.

- Lamp type : PAR20, PAR16
- Wattages : 50
- Voltages : 120
- Avg. lamp hours : 2,000
- Dimensions (in) : 4.88 W x 7.75 H x 4.75 D
- Dimensions (cm) : 12.4 W x 19.7 H x 12.06 D
- Weight : 2 lb / .9 kg



## **IQ30 Quartz** | Catalog number : **IQ30**

For PAR30 short-neck lamps. From 20' (6.1 m), can produce a pool of light 12' 7" (3.8 m) across with a spot lamp. This luminaire uses 3-3/4" accessories.

- Lamp type : PAR30
- Wattages : 50, 60, & 75
- Voltages : 120
- Avg. lamp hours : 3,000
- Dimensions (in) : 5.5 W x 7.75 H x 5.5 D
- Dimensions (cm) : 13.97 W x 19.68 H x 13.97 D
- Weight : 1 lb / .45 kg

Altman IQseries™ Quartz is a range of PAR luminaires that deliver style, efficiency, and versatility. With their lightweight spun and extruded aluminum construction the rugged IQseries Quartz adapts easily to your needs. Features include tool-free lamp access, vertical tilt lock with degree markings, and 370° horizontal rotation. IQseries Quartz units are designed for a wide variety of tungsten halogen lamps. The IQseries Quartz luminaires are an ideal choice for all retail, display, exhibit, and residential applications. The units in the IQseries Quartz range have a durable powder coated finish and are available in black, white, or silver. Custom colors are also available. Mounting options include various track adapters, canopy, Unistrut®, stem, or pipe clamps. Numerous standard and specialty accessory options are available.



**IQ36 Quartz / AR111 | Catalog number : IQ36 and IQ36-100**

For use with 12-Volt PAR36 and AR-111 screw terminal lamps up to a maximum of 75 watts for the IQ-36 and 100 watts for the IQ36-100. From 20' (6.1 m), can produce a pool of light 2' 8" (.812 m) across with a 75-watt AR-111 spot lamp. This luminaire uses 3-3/4" accessories.

- Lamp type : PAR36 & AR111
- Wattages : 35, 50, & 75 for IQ36 and 100 watts for IQ36-100
- Voltages : 120, 240, & 277
- Avg. lamp hours : 3,000
- Dimensions (in) : 5 W x 8.625 H x 6.125 D
- Dimensions (cm) : 12.7 W x 21.9 H x 15.6 D
- Weight : 3 lb / 1.4 kg



**IQ38 Quartz | Catalog number : IQ38**

For 45- to 250-watt PAR38 lamps. From 20' (6.1m), can produce a pool of light 12' 6" (3.81 m) across with a spot lamp. This luminaire uses 4-11/16"-diameter accessories.

- Lamp type : PAR38
- Wattages : 45, 90, 120, & 250
- Voltages : 120
- Avg. lamp hours : 3,000 to 6,000
- Dimensions (in) : 6.0625 W x 8.25 H x 7.0625 D
- Dimensions (cm) : 15.4 W x 20.95 H x 17.93 D
- Weight : 2 lb / .9 kg



**IQ56 Quartz | Catalog number : IQ56**

For 300- to 500-watt PAR56 lamps. From 20' (6.1 m) can produce a pool of light 5' 4" (1.615 m) high x 11' 6" wide with a Narrow Spot lamp. This luminaire uses 6-7/16"-diameter accessories.

- Lamp type : PAR56
- Wattages : 300 & 500
- Voltages : 120
- Avg. lamp hours : 2,000 to 4,000
- Dimensions (in) : 7.625 W x 11.69 H x 8 D
- Dimensions (cm) : 19.4 W x 29.7 H x 20.3 D
- Weight : 2.5 lb / 1.13 kg

# IQseries Quartz



## **IQ64 Quartz** | **Catalog number : IQ64**

The largest of the IQseries PAR luminaires, this unit is ideal when you need maximum punch for dramatic highlighting applications. For 500-watt PAR64 lamps. From 20' (6.1 m) can produce a pool of light 4' 6" (1.37 m) high x 7' 2" (2.16 m) wide with a 500-watt Narrow Spot lamp. This luminaire uses 7-7/16"-diameter accessories.

- Lamp type : PAR64
- Wattages : 500
- Voltages : 120
- Avg. lamp hours : 2,000
- Dimensions (in) : 8.625 W x 14.69 H x 8.625 D
- Dimensions (cm) : 21.9 W x 37.3 H x 21.9 D
- Weight : 2.5 lb / 1.13 kg



## **Wall Wash** | **Catalog number : IQWW**

When you need to wash a wall or any flat plane, this compact luminaire is ideally suited to the task. With its asymmetrical reflector, you can achieve sharp cutoffs with this unit. For 100- to 200-watt T3Q/CL lamps. From 3' (.9 m), can typically produce a pool of light 12' 6" wide. (Shown with manual dimmer option.)

- Lamp type : T3Q/CL
- Wattages : 100, 150, & 200
- Voltages : 120
- Avg. lamp hours : 2,000
- Dimensions (in) : 7 W x 6.75 H x 3.125 D
- Dimensions (cm) : 17.78 W x 17.125 H x 7.94 D
- Weight : 2.9 lb / 1.315 kg



## **IQ UV70 Blacklight Flood** | **Catalog number : IQ-UV70**

This track-mountable blacklight in a compact IQseries form uses a 70-watt ultraviolet lamp, creating glowing effects from up to 20' (6.1 m) away. The IQ Blacklight Flood has all the mounting and accessory options of the IQseries plus an internal safety shutoff switch in case the UV-protective lens door is opened. This luminaire comes standard with a 50° Flood Reflector. 12° and 25° reflectors are available as accessories.

- Lamp type : MHL-70
- Wattages : 70
- Voltages : 120, 240, & 277
- Avg. lamp hours : 500
- Dimensions (in) : 6 W x 9.5 H x 6.87 D
- Dimensions (cm) : 15.24 W x 24.13 H x 17.45 D
- Weight : 7 lb / 3.17 kg



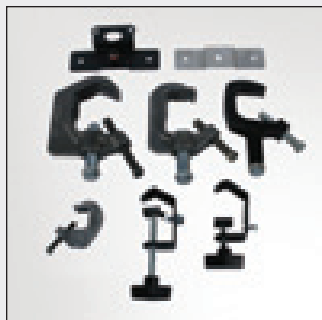

**Mounting**

**Stem Mount** for securely positioning the luminaire at a fixed distance below the mounting point.

**Unistrut Mount** for installation on standard gauges of Unistrut metal struts.

**Canopy Mounts** to mount the luminaire as a typical ceiling or wall fixture.

**Malleable Iron Pipe Clamp** to install the fixture on a thicker pipe. For pipe .75" – 1.5" in diameter.

**Baby Pipe Clamp** for a low-profile mounting on thinner pipes. For pipes .25" – 1" in diameter.



**Beam Shaping**

**Cylindrical Hood** to control spill and glare. (Shown at left.)

**Sparkle Cylindrical Hood** to control spill and glare adding a decorative sparkle effect.

**4-Leaf Barndoor** for precise control of the light pool's boundary, by cutting it along straight rectangular edges.

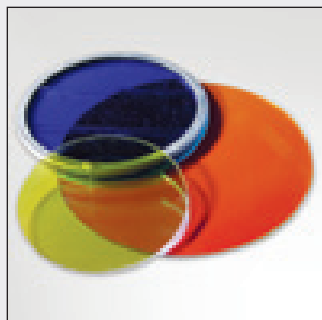

**--Color Filters and Lens Accessories**

**Color Filter Holder** allows you to place plastic color media in the luminaire. Metal screens can also be added that allow for mechanical dimming of the light, especially useful with non-dimmable CDM units.

**Dichroic Color Filters** are specially-coated glass filters that allow for higher transmission of a particular color, especially darker colors. They are environmentally durable and will not deteriorate over time.

**Also Available** are linear and spread lenses, Pyrex® glass lenses, ultraviolet filters, as well as stripped glass color filters that allow for thermal expansion.



**Other Accessories**

**Honeycomb Louver** will cut down on glare and light trespass from the luminaires. (Shown at left.)

**Coiled Cord with Edison Connector** can be factory-installed on luminaires for special applications. The cable has a molded 15A parallel blade with ground (PBG) connector.

**Switch Assembly** can be factory-installed on luminaires for easy on/off control of CDM and standard quartz luminaires.

# IQseries Track Adapters

The IQseries luminaires work for a variety of applications, especially for track lighting solutions. If you already have track installed from other manufacturers, you can adapt the IQseries units to your particular track with the adapters listed below.

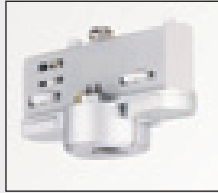

## Smart-Track™ Adapter | Catalog number : -Y

This adapter will allow a Smart Altman Luminaire to be controlled on the Smart Track Lighting System. Note: Line voltage luminaires for Smart Track will have an on board DMX / RDM addressable dimmer; Metal halide will have an on board DMX/ RDM addressable on/ off relay; LED Luminaires will have on board power supply and DMX / RDM addressable interface.

Smart-track has two x 20-Amp circuits of power with independent neutrals & built in dmx data bus.  
For more on Altman Smart Track see page 5 or visit [www.altmanlighting.com](http://www.altmanlighting.com) for the full Altman Smart Track Manual.



## Global trac® eco

### Catalog number : ASL-E166 (one- and two-circuit)

This will adapt luminaires to work with the Nordic Aluminum Global trac® eco series track. The eco track is available in one- and two-circuit versions.



## Global trac® tek | Catalog number : TLA-TEK100

This will adapt track luminaires to the Nordic Aluminum Global trac® tek series track. This track has two circuits with two neutral conductors and is designed for dimming-intensive applications.



## Eutrac Multiadapter | Catalog number : ASL-779\*

The MultiAdapter is compatible with the ASL-230\* series 2 Circuit Track. This adapter comes complete with two mechanical supports and a tool free user selectable circuit switch.



## Halo® | Catalog number : TLA-H

This adapter allows you to add Altman IQseries luminaires to Halo® track.

## Juno® | Catalog number : TLA-J

This adapter allows you to add Altman IQseries luminaires to Juno® track.

## Lightolier® | Catalog number : TLA-L

This adapter allows you to add Altman IQseries luminaires to Lightolier® Lytespan track.



The Smart-Track Lighting System at the John G. Shedd Aquarium  
Polar Play Zone Exhibit, Chicago, IL  
Photo Credit & Lighting Design by: Lightswitch Architectural  
[www.Architectural.lightswitch.net](http://www.Architectural.lightswitch.net)

# Spectraseries



## **Spectra-CYC | Catalog number : SS-CYC-100**

The Spectra CYC is a 100 Watt cyclorama/ wall wash luminaire utilizing red, green, blue and amber LED emitters. Designed for theatrical and architectural applications, the Spectra CYC blends colors via a patent pending LED lens which reduces pixelization from direct view. The on board power supply allows for direct power & data input which can be daisy chained thru 10 units. Designed for use on 4'-6' centers, individual units can be linked side by side for greater saturation of light. The Spectra CYC is compatible with both DMX and RDM protocols, and comes complete with a library of pre-programmed single colors to various color mixes. Units are made for floor or Sky-Cyc applications.

- Red, Green, Blue & Amber 3 Watt LED emitters - 100 watts at full RGBA
- Patent Pending LED blending lens & A-Symmetrical reflector
- On Board Multi Voltage Power Supply - 100-240 volts AC
- Feed thru data and power capabilities
- Compatible with DMX and RDM protocols
- Pre-programmed modes
- Push button addressing
- ETL and cETL Listed
- Weight: Approx; 11 lbs (4.99 kg)



## **Spectra-Par 100 | Catalog number : SS-PAR-100**

The SPECTRA PAR 100 is a 100 Watt par luminaire utilizing red, green, blue and amber LED emitters. Designed for theatrical and architectural applications, the SPECTRA PAR 100 acts as a true par lighting fixture complete with interchangeable VNSP, NSP, MFL and WFL lenses. The on board power supply allows for direct power input. Data can be easily daisy chained from fixture to fixture. The SPECTRA PAR 100 is compatible with both DMX and RDM protocols, and comes complete with a library of pre-programmed single colors and various color mixes. Certified for use in both indoor or outdoor applications.

- Red, Green, Blue & Amber 3 Watt LED emitters - 100 watts at full RGBA
- Interchangeable par lenses - Very Narrow, Narrow, Medium and Wide Flood
- On Board Multi Voltage Power Supply - 100-240 volts AC
- Feed thru data capabilities
- Compatible with DMX and RDM protocols
- Pre-programmed modes
- Push button addressing
- ETL and cETL Listed for indoor and outdoor applications-IP65
- Weight: Approx; 22 lbs (9.98 kg)

\* Altman Lighting, Inc. illumination products utilize high brightness LEDs as the illumination source. LED manufacturers predict LED life of up to 100,000 hours MTBF (mean time between failure). Be standard used by conventional lamp manufacturers to measure source life. However, like all basic light sources, LEDs also experience lumen depreciation over time. So while LEDs can emit light for an extremely long period of time, MTBF is not the only consideration in determining useful life. LED lumen depreciation is affected by numerous environmental conditions such as ambient temperature, humidity and ventilation. Lumen depreciation is also affected by means of control, thermal management, current levels, and a host of other electrical design considerations. Altman systems are expertly engineered to optimize LED life when used under normal operating conditions [ambient temperature: -4° F to 104° F (-20° C to 40° C); humidity: 0-95% non-condensing humidity, adequate ventilation and air volume] and when operated using typical color-changing effects. Long-term operation outside of these ranges or conditions, or at the upper limits of these ranges or conditions, may subject the product to further degradation of the LED source life, or in extreme cases, failure of internal components. Source life information is based on LED manufacturers' data, as well as other third party testing.

Altman has been a leader in adapting LED technology with its luminaire range. Whether it's indoors or outdoors, Altman has an LED luminaire for most applications in both Red, Green, Blue & Amber color mixing or 3000 degree Kelvin white. In the IQseries, there are Par38 and Par64 sized units available to work with the Smart-Track Lighting System for interior applications. Portable and non-DMX versions are also available. The Spectra Par 100 luminaire can work just about anywhere with its innovative designs that are dust and water resistant. This unit can provide a powerful punch of light while drawing very little energy and with the interchangeable lenses, you have control over the output. The Spectra Cyc 100 luminaire is perfect for lighting large vertical surface with it's broad and even light distribution. The Altman Spectra Series luminaires operate with both DMX and RDM protocols.



**Spectra CYC White | Catalog number : SSW-CYC-100-3-\***

The Spectra CYC White is a 100 Watt Cyclorama/ wall wash luminaire utilizing 3000 Degree Kelvin white light Luxeon Rebel LED's. Designed for theatrical and architectural applications, the Spectra CYC White blends the emitting light via a patent pending LED lens which reduces pixelization from direct view. The on board power supply allows for power and data input which can be daisy chained thru 12 units. The Spectra Cyc White is designed for use with both DMX and RDM protocols and comes complete with pre-programmed modes such as manual dim and full on.

- Light Engine : Luxeon Rebel 3000 Degree Kelvin LED's
- Wattages : 100
- On Board Multi Voltage Power Supply - 100-240 volts AC
- Pre-programmed modes
- Push button addressing
- User selectable 8 and 16-bit personalities for smooth fades
- ETL and cETL Listed
- Weight: Approx; 11 lbs (4.99 kg)



**Spectra Par White | Catalog number : SSW-PAR-100-3-\***

The Spectra Par White is a 100 Watt par luminaire utilizing 3000 degree Kelvin white light Luxeon Rebel LED's. Designed for theatrical and architectural applications, the Spectra Par White acts as a true par lighting fixture; complete with interchangeable VN5P, NSP, MFL and WFL lenses. The on board power supply allows for direct power. Data can be easily daisy chained from fixture to fixture. The Spectra Par White is designed for use with both DMX and RDM protocols and comes complete with pre-programmed modes such as manual dim and full on. Certified for use in both indoor and outdoor applications.

- Light Engine : Luxeon Rebel 3000 Degree Kelvin LED's
- Lamp type : Tungsten Halogen
- Wattages : 100
- On Board Multi Voltage Power Supply - 100-240 volts AC
- Pre-programmed modes
- Push button addressing
- User selectable 8 and 16-bit personalities for smooth fades
- ETL and cETL Listed for indoor and outdoor applications-IP65
- Weight: Approx; 22 lbs (9.98 kg)

# Spectraseries



## **Spectra Star\*Par 100 | Catalog number : SS-SP\***

The Spectra Star\*Par 100 is a 100 Watt PAR Luminaire utilizing high efficiency red, green, blue, and amber LED emitters. Featuring a durable, light weight die cast aluminum housing the The Spectra Star\*Par is available as a pipe mount or Smart Track™ fixture. Designed for theatrical and architectural applications, the Spectra Star\*Par acts as a true PAR lighting fixture with tool-free interchangeable VNSP, NSP, MFL, WFL, and (optional) XWFL Lenses.

- Red, Green, Blue & Amber Rebel LED's - 100 Watts Max.
- Portable and Smart-Track Lighting System options available
- Tool-free interchangeable Par 64 lenses (VNSP, NSP, MFL & WFL)
- Compatible with DMX and RDM protocols
- DMX assignable via RDM or on-board push button display
- User selectable 8 and 16-Bit personalities for smooth fades
- Pre-programmed modes for fixed colors, timed color changes & strobes for "set & forget" operation
- On board multi-voltage power supply: 100-240 VAC
- Black, white & silver paint finishes available
- Weight: Approximately 16 lbs. (7.3 kg)
- ETL & cETL Listed



## **Spectra Star\*Par White 100 | Catalog number : SSW-SP\***

The Spectra Star\*Par 100 White is a 100 Watt PAR Luminaire utilizing high efficiency warm white LED emitters with a 3000° Kelvin color temperature. Featuring a durable, light weight die cast aluminum housing the Spectra Star\*Par White is available as a pipe mount or Smart Track™ fixture. Designed for theatrical and architectural applications, the Spectra Star\*Par White acts as a true PAR lighting fixture with tool-free interchangeable VNSP, NSP, MFL, WFL, and (optional) XWFL Lenses.

- 3000° Kelvin high CRI Luxeon Rebel LED's - 100 Watts Max.
- Portable and Smart-Track Lighting System options available
- Tool-free interchangeable Par 64 lenses (VNSP, NSP, MFL & WFL)
- Compatible with DMX and RDM protocols
- DMX assignable via RDM or on-board push button display
- User selectable 8 and 16-Bit personalities for smooth fades
- On board intensity controls for "set & forget" operation
- On board multi-voltage power supply: 100-240 VAC
- Black, white & silver paint finishes available
- Weight: Approximately 16 lbs. (7.3 kg)
- ETL & cETL Listed



### OUTDOOR SPECTRA CYC 100 | Catalog number: SS-OD-CYC-100-\*

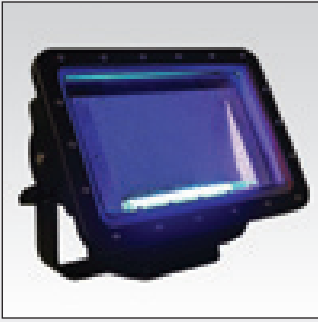

The OUTDOOR SPECTRA CYC RGBA is a 100 Watt cyclorama/ wall wash luminaires utilizing red, green, blue and amber LED emitters. Designed for Architectural & Theatrical applications, the OUTDOOR SPECTRA CYC RGBA blends colors with a patent pending LED lens that reduces pixelization from direct view.

- Red, Green, Blue & Amber Luxeon Rebel LED's
- Die Cast Aluminum Housing
- 100 Watt 3000° Kelvin White Light Engine also available PT# **SSW-OD-CYC-3K-\***
- Feed thru data capabilities
- DMX Address assignable via RDM or on-board push button display
- Pre-programmed modes for fixed colors, timed color changes and strobes.
- On board multi-voltage power supply 100-240 VAC
- Weight: Approximately 22 lbs. (9.988 kg)
- ETL & cETL Listed for Indoor/ Outdoor Use IP65
- Made in the USA

### Spectra Par IQ38 | Catalog number : SS-IQ38\*-50\*



- Designed for use w/ the Altman Smart-Track Lighting System
- Red, Green, Blue & Amber Luxeon Rebel LED's- 50 Watts
- Internal accessory holder for spread lenses & louvers
- On board multi-voltage power supply; 100-240 VAC
- Compatible with DMX and RDM protocols
- Push button addressing
- User selectable 8 and 16-bit personalities for smooth fades
- Pre-programmed modes for fixed colors, timed color changes & strobes.
- Canopy, portable & Non-DMX track options available
- Optional 4 way barn doors
- Weight: 8 lbs (3.64 kg)
- ETL & cETL Listed

### Spectra Par IQ38 White | Catalog number : SSW-IQ38\*-503\*



- Designed for use w/ the Altman Smart-Track Lighting System
- 3000° Kelvin white light LED emitters - 50 Watts Total
- Internal accessory holder for spread lenses & louvers
- On board multi-voltage power supply; 100-240 VAC
- Compatible with DMX and RDM protocols
- Push button addressing
- User selectable 8 and 16-bit personalities for smooth fades
- Canopy, portable & Non-DMX track options available
- Pre-programmed modes for full on or manual dimming
- Optional four way barndoors
- Weight: 8 lbs (3.64 kg)
- ETL & cETL Listed

### ME3 LED Framing Projector | Catalog number : ME3-\*



- The first fully functioning white light LED Ellipsoidal
- 1,200 Lumen White LED light engine - 25 Watts Total
- 3,000° Kelvin - High CRI
- Dimmable on the Altman Smart-Track Lighting System
- Compatible w/ RDM & DMX protocols on Smart-Track
- Crisp Zoom optics
- Four framing shutters for precise cropping of the beam
- Accepts optional steel & glass templates
- Portable, track & canopy mount options available
- Weight: 7 lbs (2.8 kg)
- ETL & cETL Listed

### Micro Flood LED | Catalog number : MF3\*



- 1,200 Lumen White LED light engine - 25 Watts Total
- 3,000° Kelvin - High CRI
- Specular aluminum reflector for broad even wash
- Dimmable on the Altman Smart-Track Lighting System
- Compatible w/ RDM & DMX protocols on Smart-Track
- Portable, track & canopy mount options available
- Optional barndoors available
- ETL & cETL Listed

# Outdoor



Shown with optional ODC-SN-SHORT

## Outdoor PAR CDM | Catalog number : ODC-A

This low-power luminaire in a PAR64 format accepts efficient, low-heat CDM lamps of 39-, 70-, and 150-watts rated at 12,000 hours of operation. At a distance of 40' (12.2 m), the Outdoor PAR CDM typically produces a pool of light 13' (4.0 m) in diameter with a Narrow Spot lens, and a pool 37.5' (11.4 m) in diameter with a Wide Flood lens.

- Lamp type : CDM T6
- Wattages : 39, 70, & 150
- Voltages : 120, 240, & 277
- Avg. lamp hours : 12,000
- Dimensions (in) : 13.25 W x 16.5 H x 11.57 D
- Dimensions (cm) : 33.7 W x 41.7 H x 29.4 D
- Weight : 18 lb / 8.16 kg



## Outdoor 600 Halogen | Catalog number : OD600-A

A high-performance alternative to conventional PAR64 luminaires, the Outdoor 600 accepts 375-, 575-, 600-, and 750-watt tungsten-halogen lamps. At a distance of 40' (12.2 m), this unit can produce a pool of light 11' (3.4 m) in diameter with a Narrow Spot lens, and a pool 33' (10.1 m) in diameter with a Wide Flood lens.

- Lamp type : Tungsten Halogen
- Wattages : 375, 575, 600, & 750
- Voltages : 120 & 240
- Avg. lamp hours : 300 - 1,500
- Dimensions (in) : 13.25 W x 16.5 H x 11.57 D
- Dimensions (cm) : 33.7 W x 41.7 H x 29.4 D
- Weight : 14 lb / 6.35 kg



Shown with optional OD-P64-SN

## Outdoor PAR 64 | Catalog number : OUTDOOR-PAR64

This rugged wet-location luminaire accepts standard PAR64 lamps of 500- and 1000-watts. Typical lamp life varies from 600 to 4,000 hours of continuous use. At a distance of 40' (12.2 m), this unit can produce a pool of light 14' 2" (4.3 m) in diameter with a spot lamp and a pool 45' 2" (13.8 m) in diameter with a Wide Flood lamp. (Shown with Snoot/Accessory Holder.)

- Lamp type : PAR64
- Wattages : 500 & 1000
- Voltages : 120 & 240
- Avg. lamp hours : 600 - 4000
- Dimensions (in) : 13.25 W x 16.5 H x 11.57 D
- Dimensions (cm) : 33.7 W x 41.7 H x 29.4 D
- Weight : 18 lb / 8.16 kg

Combining legendary Altman performance with exceptional use of space and form, these hardworking luminaires deliver the intensity, quality, and beam-shaping features critical to so many uses. Designed for wet and damp installations, they are equally at home indoors, especially in high-traffic or other demanding environments. Every Altman outdoor luminaire uses heavy gaskets at all joinings, protecting the lamp, reflector, and internally-mounted electronics. And you don't have to sacrifice simplicity and flexibility. With tool-free aiming, focus/zoom, re-lamping, and reflector/lens access, these units are remarkably easy to use. All hybrid PAR luminaires come with four interchangeable lenses, from Very Narrow Spot to Wide Flood, rotatable 360° for maximum functionality. Durable, simple, flexible, functional. With Altman Outdoor luminaires, you will truly discover the quality of light.

**Miniature Outdoor Framing Projector** Catalog number : MINI-ODEC



The Altman MINI-ODEC is the first fully functional miniature outdoor ellipsoidal with 20-40 degree zoom focus , framing shutters, glass/ steel pattern projection capabilities, internal mounting options for color media. The removable lid allows for maximum accessibility during installation, lamp changes or lens adjustments. Two stainless steel safety cables hold the lid securely when the fixture is opened. The lid is secured to the body with four side-mounted link-lock latches that provide a water tight seal. The proprietary highly polished reflector is engineered for use with T6 G12 CDM lamps for maximum light output.

- Lamp type : CDM T6
- Wattages : 39, 70 & 150
- Voltages : 110-277V
- Avg. lamp hours : 12,000
- Dimensions (in) : 6.125 W x 8.875 H x 22 D
- Dimensions (cm) : 15.55 W x 22.5 H x 55.88 D
- Weight : 12 lb / 5.45 kg

**Outdoor Framing Projector**  
Catalog number : ODEC 15° - 35° or 30° - 55° Zoom



A 70 or 150-watt CDM outdoor framing projector with a 15° - 35° zoom or 30° - 55° zoom, framing shutters, glass/steel pattern projection capabilities, and internal accessory mounting options for color media or a douser. Four side-mount latches provide a water-tight seal. The lid and body are fabricated of rugged aluminum with stainless steel fittings and UL and cUL listed for wet locations.

- Lamp type : CDM T6
- Wattages : 70 & 150
- Voltages 120, 240, & 277
- Avg. lamp hours : 12,000
- Dimensions (in) : 9.87 W x 9.37 H x 33 D
- Dimensions (cm) : 25.1 W x 24.4 H x 90 D
- Weight : 35 lb / 15.9 kg

**Outdoor Blacklight Flood** | Catalog number : UV-150



This high-output UV luminaire in a PAR64 format, rated for wet or damp locations, creates glowing effects from up to 40' (12.2 m). Compact and quiet, this unit, which uses a 500-hour 150-watt MHL lamp, comes with four interchangeable focusing lenses and has the same mounting and accessory options as the Outdoor PAR series.

- Lamp type : MHL
- Wattages : 150
- Voltages : 120, 240, & 277
- Avg. lamp hours : 500
- Dimensions (in) : 13.25 W x 14.75 H x 11.57 D
- Dimensions (cm) : 33.7 W x 37.5 H x 29.4 D
- Weight : 18 lb / 8.16 kg

# Indoor Display



## Star★PAR CDM | Catalog number : SPC-A

The award-winning Star★PAR utilizes 39-, 70-, and 150-watt CDM lamps. At a distance of 20' (6.1 m), the Star★PAR CDM produces a circular pool 7' (2.1 m) in diameter with a Narrow Spot lens, and an oval beam 15' H x 23' W (4.6 m x 7 m) with a Wide Flood lens. Simple beam control is achievable with four included interchangeable lenses, rotatable 360°.

- Lamp type : CDM T6
- Wattages : 39, 70, & 150
- Voltages : 120, 240, & 277
- Avg. lamp hours : 12,000
- Dimensions (in) : 13 W x 15.5 H x 11.5 D
- Dimensions (cm) : 33.0 W x 39.4 H x 29.2 D
- Weight : 12 lb / 5.4 kg



## Shakespeare CDM Ellipsoidals | Catalog numbers : S6C-5, S6C-10, S6C-20, S6C-30, S6C-40, S6C-50

These framing luminaries use low-power 39-, 70-, and 150 watt CDM lamps. Available in 5°, 10°, 20°, 30°, 40°, and 50° beam spreads.

- Lamp type : CDM T6
- Wattages : 39, 70, & 150
- Voltages : 120, 240, & 277
- Avg. lamp hours : 12,000

### For S6C-20, S6C-30, S6C-40, S6C-50 :

- Dimensions (in) : 12 W x 17 H x 26.25 D
- Dimensions (cm) : 30.5 W x 43.2 H x 66.7 D
- Weight : 21.5 lb / 9.7 kg



## Shakespeare Zoom CDM

### Catalog numbers : S6C-1535Z, S6C-3055Z

These units vary their spot sizes without remounting and use standard CDM lamps. From 40' (12.2 m), the 15° to 35° model produces a spot between 6' 4" to 10' 6" (1.9 to 3.2 m) and the 30° to 55° a spot 9' 1" to 10' 6" (2.8 to 3.2m).

- Lamp type : CDM T6
- Wattages : 39, 70, & 150
- Voltages : 120, 240, & 277
- Avg. lamp hours : 12,000
- Dimensions (in) : 12W x 17H x 30D (S6C-1535Z)  
12W x 17H x 24.75D (S6C-3055Z)
- Dimensions (cm) : 30.5W x 43.2H x 76.2D (S6C-1535Z)  
30.5 W x 43.2 H x 63 D (S6C-3055Z)
- Weight : 23 lb / 10.4 kg (S6C-1535Z) / 21 lb / 9.5 kg (S6C-3055Z)



### Micro Ellipse | Catalog number : ME

This micro projector uses standard 20- to 75-watt MR16 reflector lamps and projects colors, patterns or images. It works with the Master Spin image rotator for dynamic movement of an image. At a distance of 15' (4.6 m), this unit produces a spot 6' 1" to 9' 4" (1.9 to 2.8 m) in diameter. This luminaire accepts all standard 3.375" accessories.



### Micro Ellipse II | Catalog number : ME2

The ME2 ellipsoidal is a state of the art pattern projector with a 25 to 45 degree variable zoom focus. The anti-reflective coated, high performance lenses deliver bright & crisp pattern or graphic projections via an optional steel or glass E size pattern. The dual lenses of the ME2 move smoothly and evenly on guide rods with Teflon bushings to provide accurate alignment. Four framing shutters are provided for precise cropping of the projected light. The ME2's small size and projection optics makes it perfect for museums, retail, restaurant and all architectural venues requiring a small ellipsoidal framing projector with crisp projections.



### Micro PAR | Catalog number : MP

Compact and functional, this luminaire uses standard 50-watt PAR16 and PAR20 lamps and accepts all standard 3.375" accessories. At 15' (4.6 m), this unit typically produces a pool of light 3' 2" (1.0 m) in diameter with a spot lamp, and a pool 8' 7" (2.6 m) with a flood lamp.



### Micro Flood CDM | Catalog number : MFC

The Micro Flood CDM is a compact and lightweight soft-edged spotlight designed to produce narrow to wide beam spreads which are a function of the lamp. The luminaire utilizes the MR16 20W GX10 spot or flood Ceramic Metal Halide lamps. The MFC is designed for use on track, surface mount or cord and plug applications and accepts a color frame and or barndoors.



### Micro Flood | Catalog number : MF

Ideal for small format display or accent work, this lightweight luminaire uses 20- to 75-watt MR16 reflector lamps and standard 3.375" accessories. From 15' (4.6 m), the Micro Flood can produce a pool of light 4' 5" to 12' (1.3 to 3.7 m) in diameter.



### Master Ellipse CDM | Catalog number : MAC

The Master Ellipse projects a spot from up to 35' (10 m) away. Zoom adjustment and integrated shutters let you vary the beam size and shape. Plus, it uses low-heat, low-maintenance 39-, 70-, and 150-watt CDM lamps. From 20' (6.1 m), this unit can produce a spot 3' 5" to 12' (1.0 to 3.7 m) across. This luminaire works with the Master Spin image rotator and accepts all standard 3.375" accessories.



### Master Spin Accessory | Catalog number : MSPIN

The MasterSpin™ is a double pattern rotator that delivers kinetic lighting effects by counter-rotating two patterns simultaneously at specific selectable speeds. This accessory accepts up to two size-E (37.5 mm) patterns of steel, glass, or a combination of the two. It fits in the pattern slot of the Altman Master Ellipse or Micro Ellipse luminaires.

# Focus on CUSTOM LIGHTING



Altman Lighting brings innovative engineering expertise as well as exemplary technical fabrication abilities to every custom project. We excel at projects with specific custom requirements.

Skilled, experienced staff using state-of-the-art equipment assures you of products to meet all your custom lighting needs. Altman controls all processes in-house to meet your exact specifications and requirements. Our design and engineering staff have worked with some of the top lighting designers and architects to create unique luminaires that both enhance and illuminate the environment being shaped.

Our vast experience in producing fixtures ranges from conventional incandescent to LED technology. Our Research and Development team will work with you to find the perfect solution to building an aesthetically pleasing yet ruggedly functional luminaire.

With our state of the art technology for fabrication, bending, and metal cutting, we have the machinery in-house so that we can maintain the tightest of tolerances and present the designer with the physical realization of their most innovative designs.

Utilizing the latest CAD/CAM and CNC technology, with a minimal design to finish time, Altman can insure prompt delivery. For over 55 years, Altman Lighting has known the importance of opening night and we know the importance of your deadline.

So if it's build from plans or creating a new and unique product, our talented staff of designers and engineers are ready to tackle any challenge you present us.





West Elm Store, New York City  
Lighting Design by Johnson Schwinghammer



**Distributor:**



Phone: 407-857-8770

Fax: 407-857-8771

Email: [sales@techni-lux.com](mailto:sales@techni-lux.com)

Altman Lighting, Inc.

57 Alexander St., Yonkers, NY 10701

tel: 800.4.ALTMAN (800.425.8626)

e-mail: [info@altmanlighting.com](mailto:info@altmanlighting.com)

[www.altmanlighting.com](http://www.altmanlighting.com)